



STAR WARS



8128



1

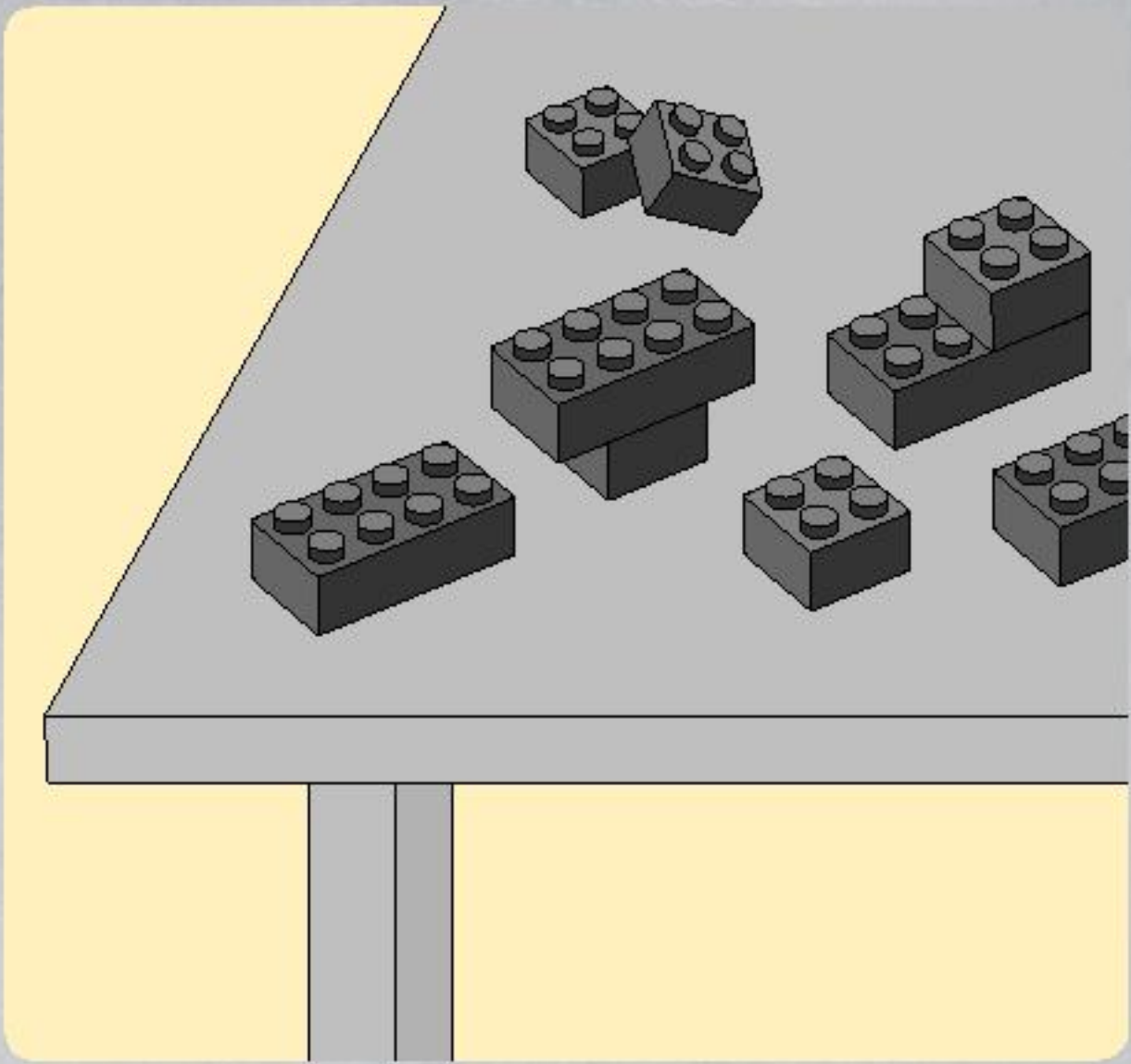
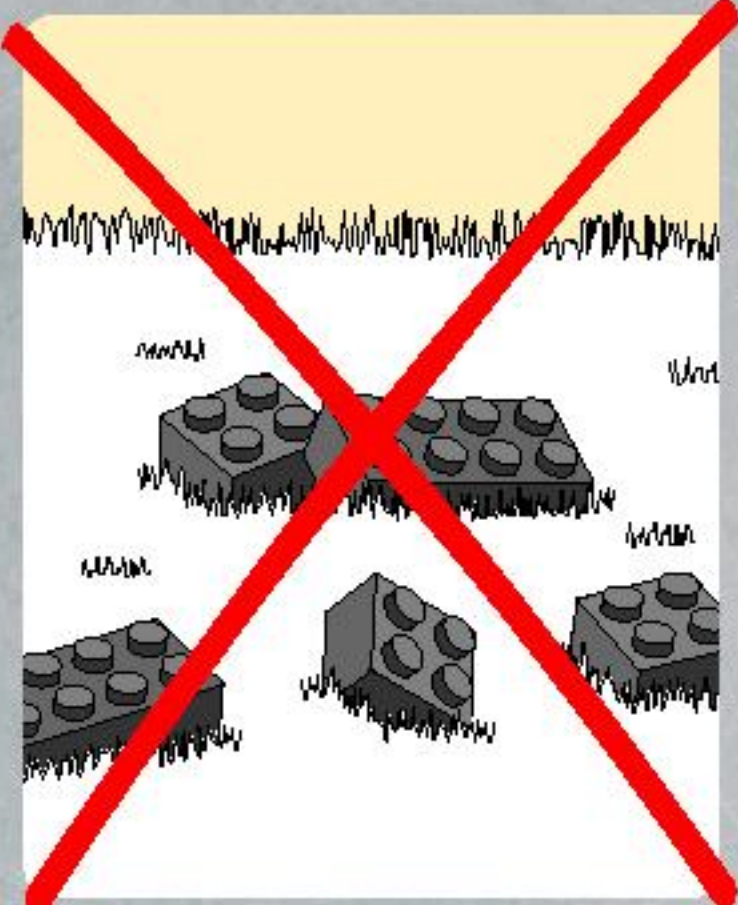

2

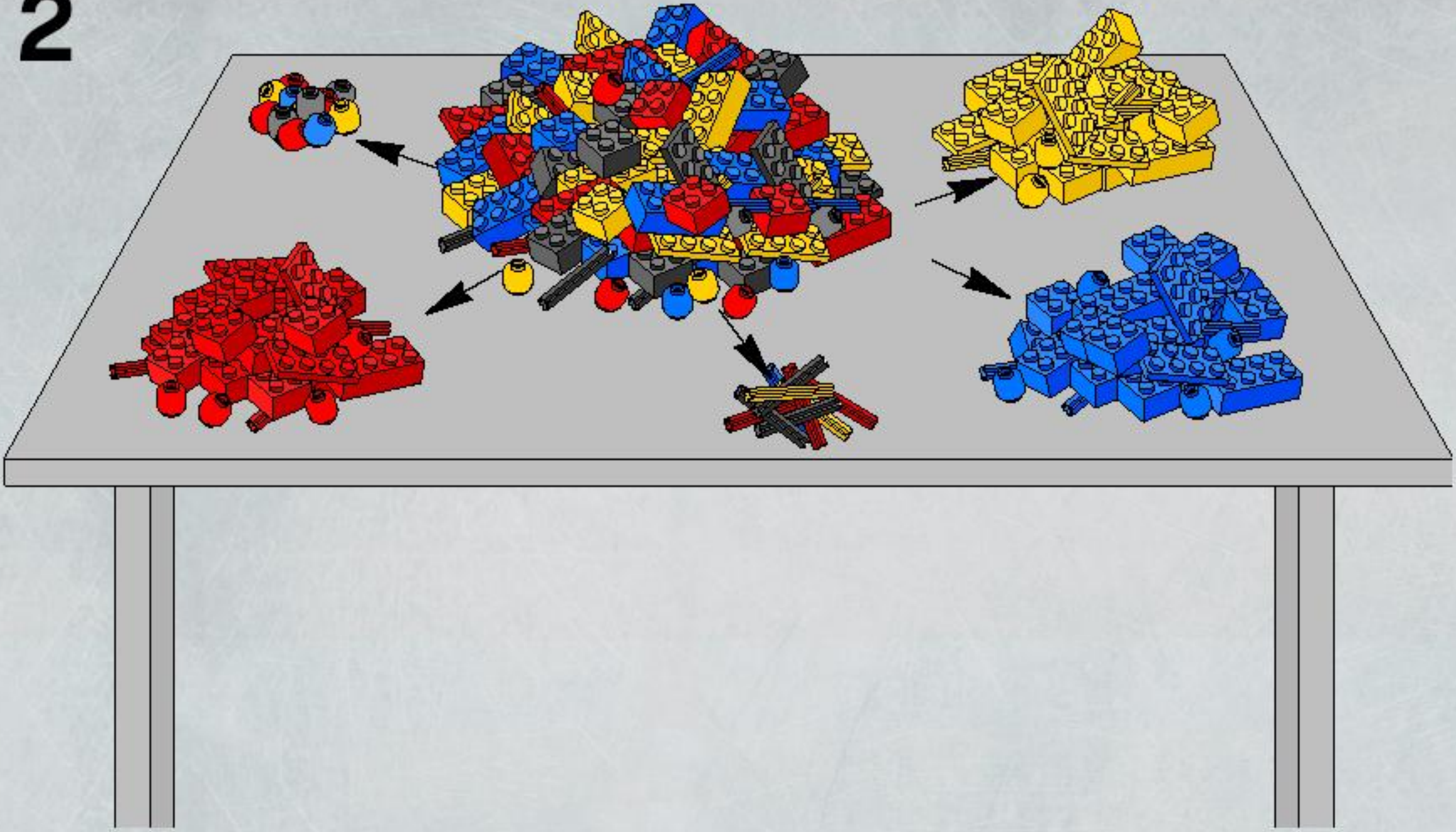

3

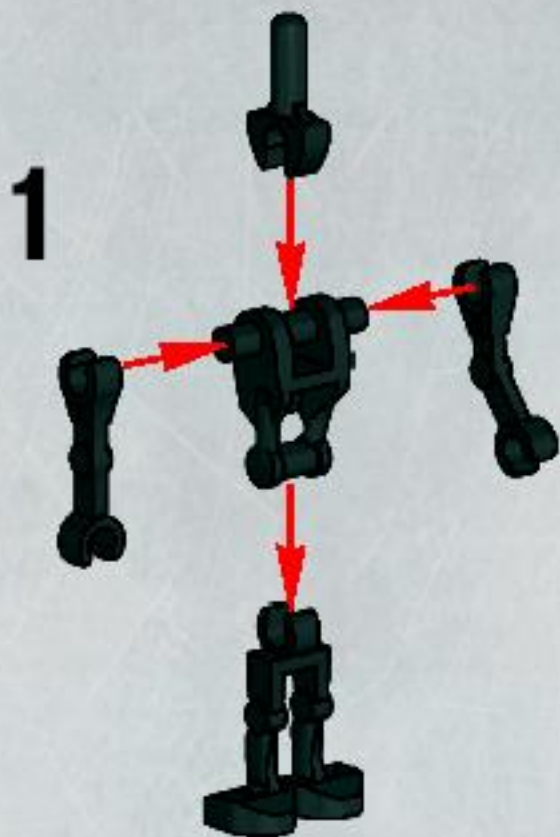
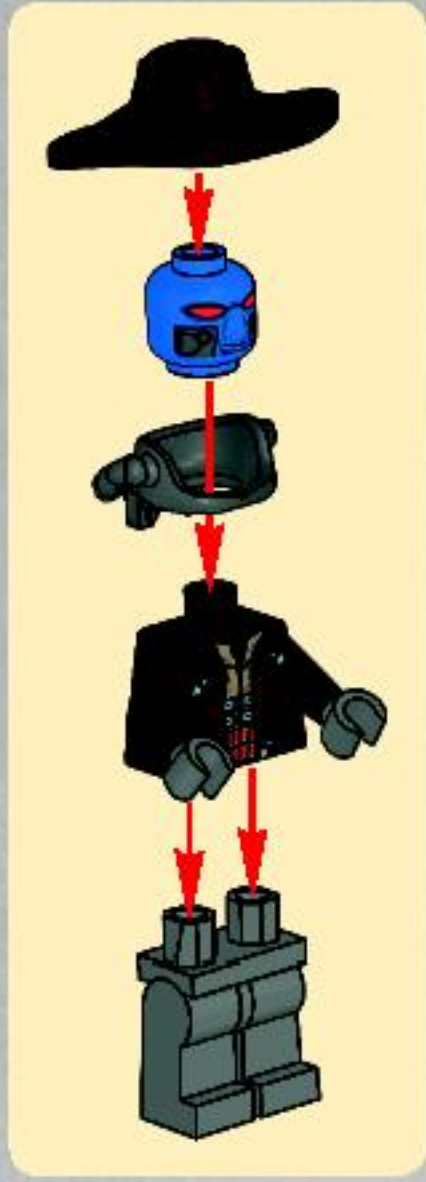

2



3



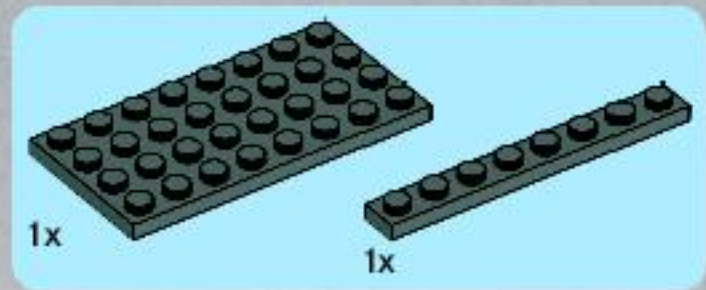

1

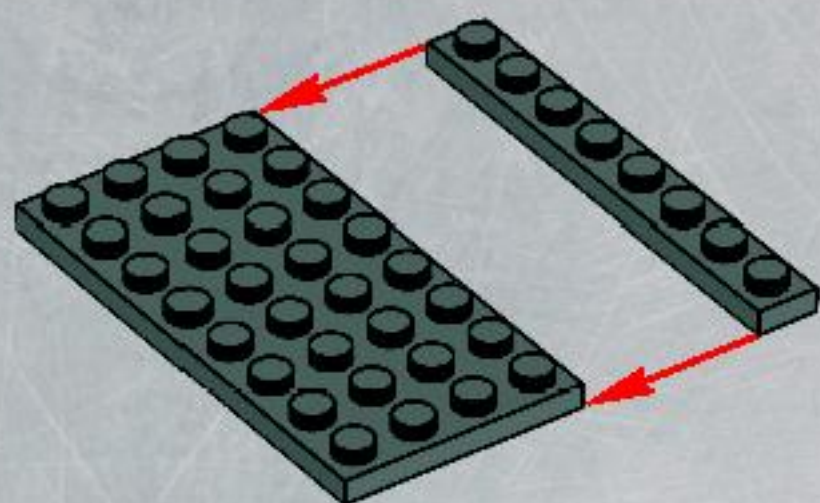

3

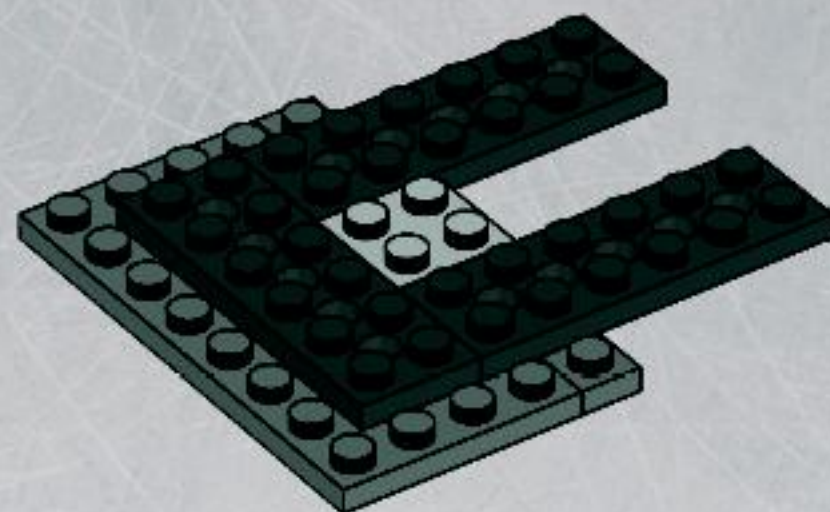

2

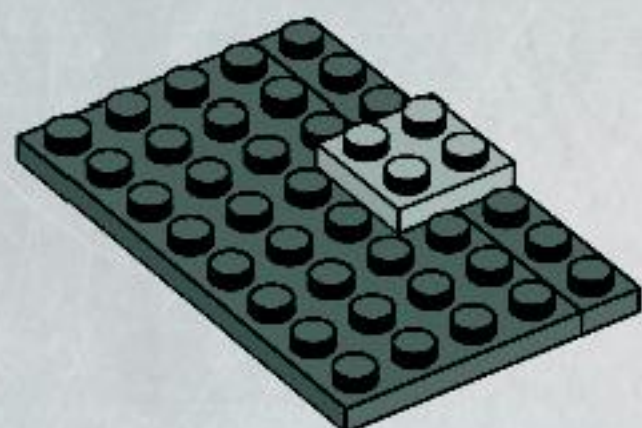

4

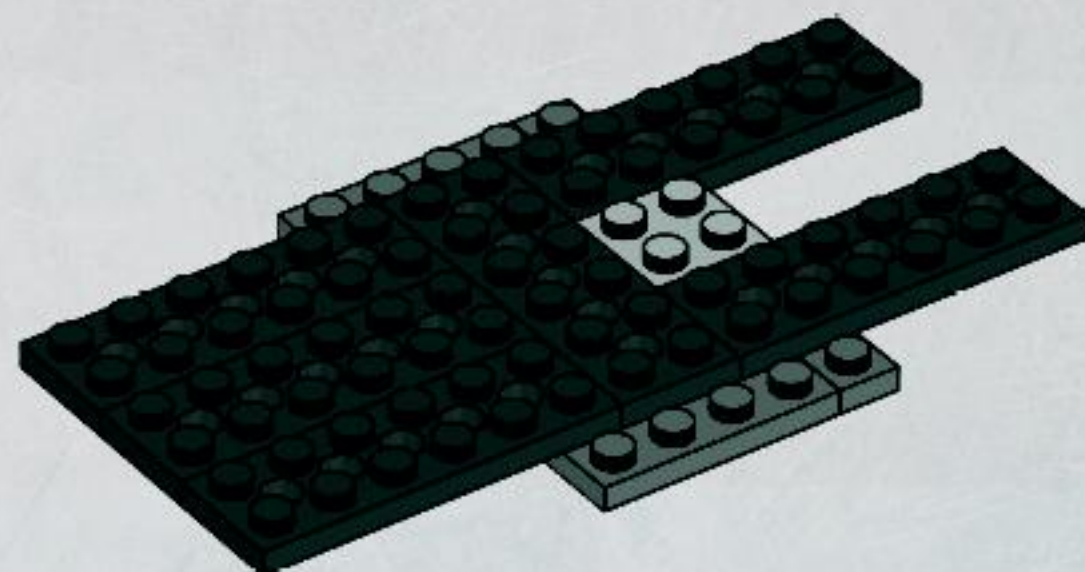

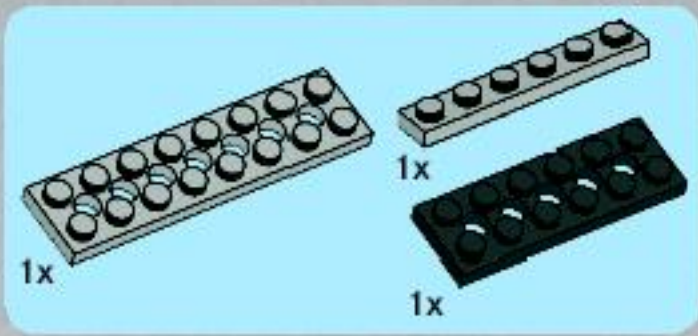

5

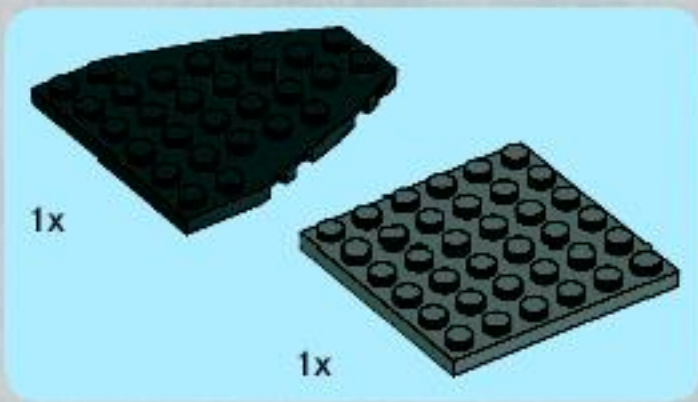
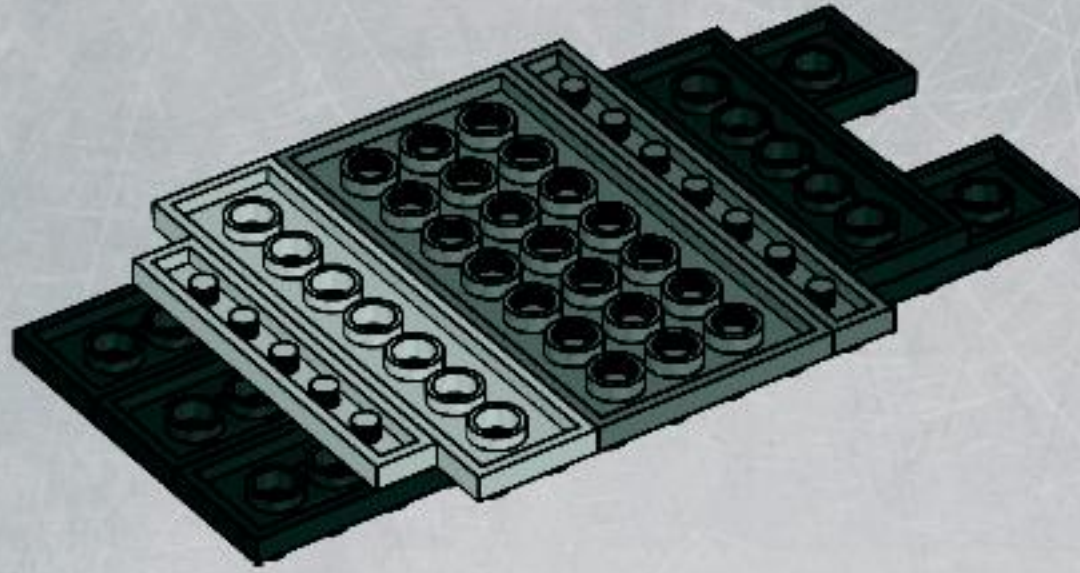

6

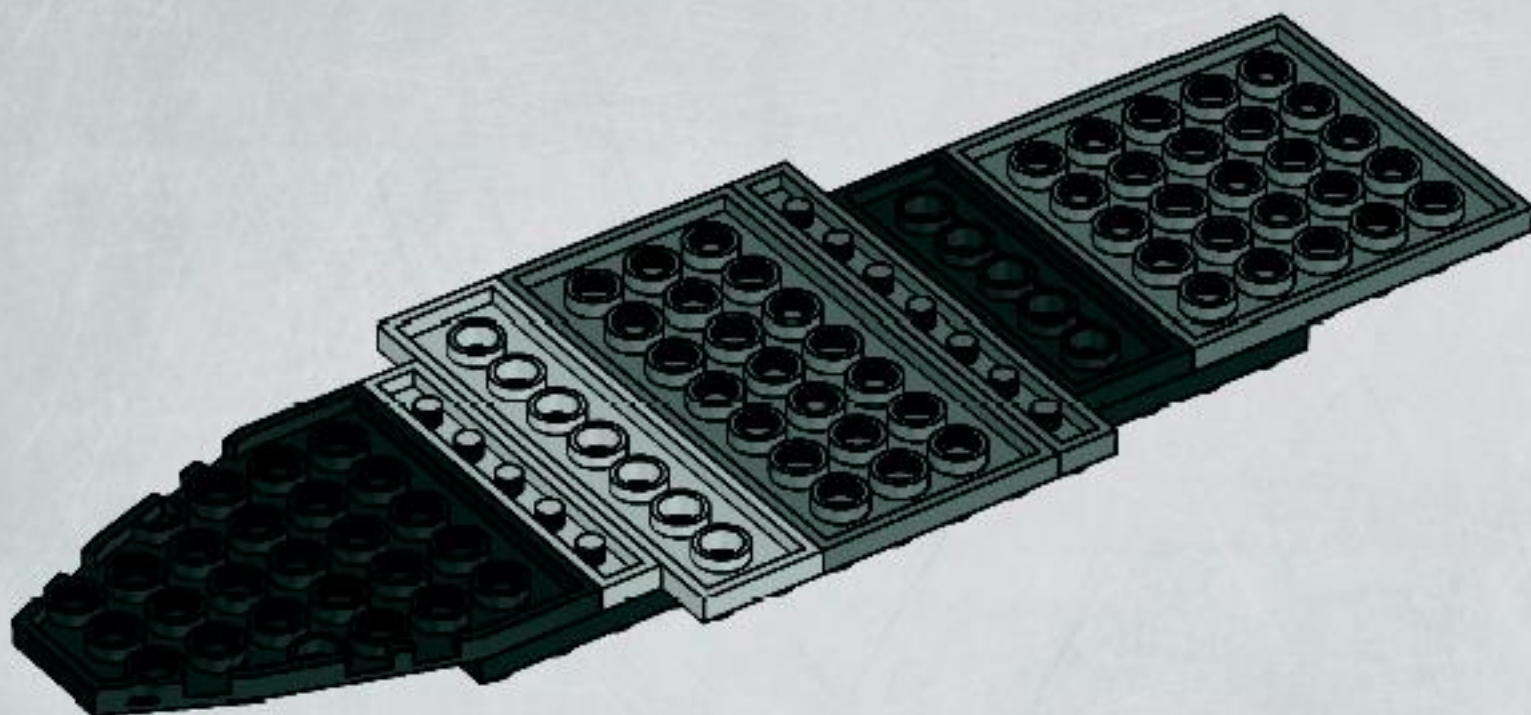



6x

7

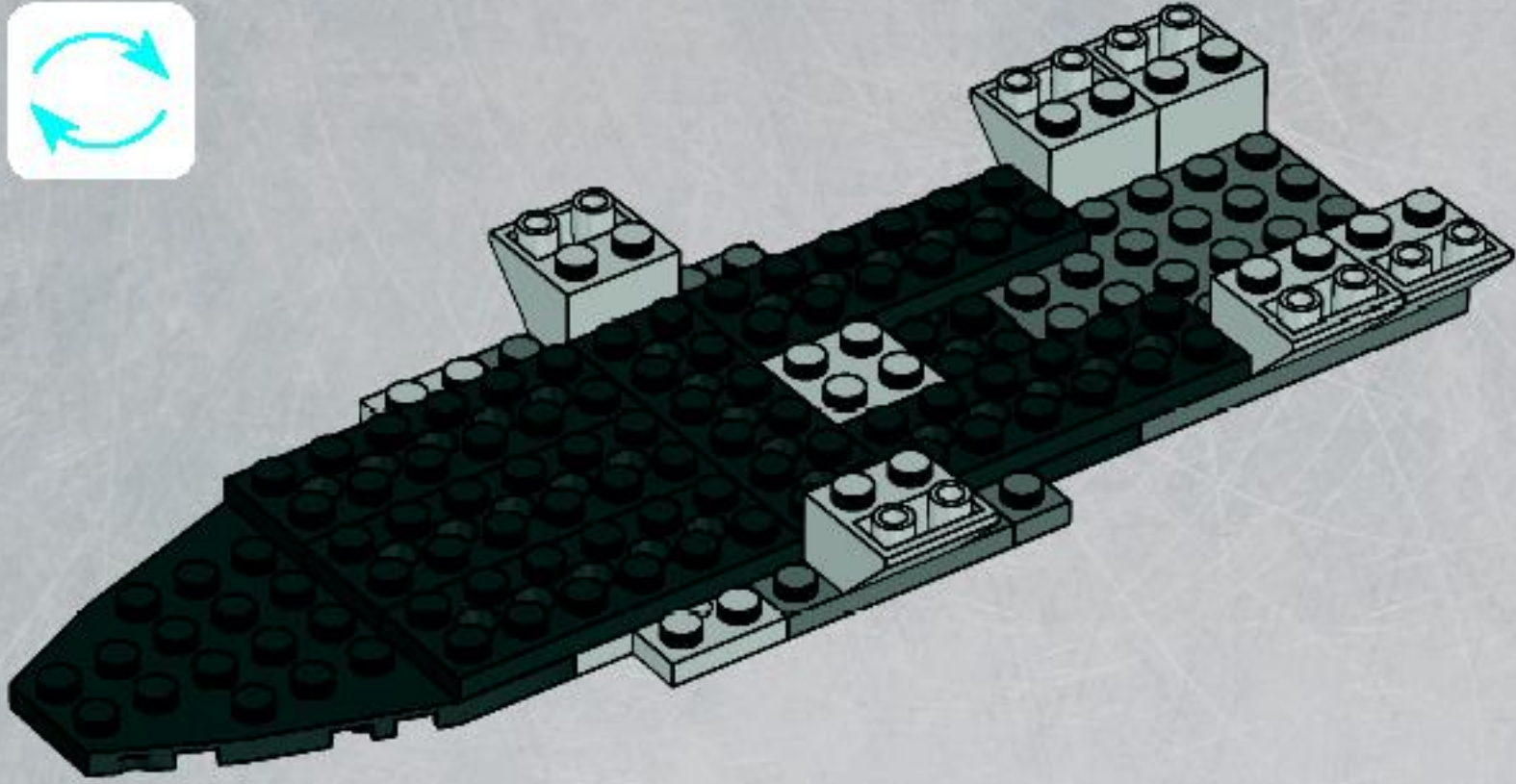

4x

8



2x

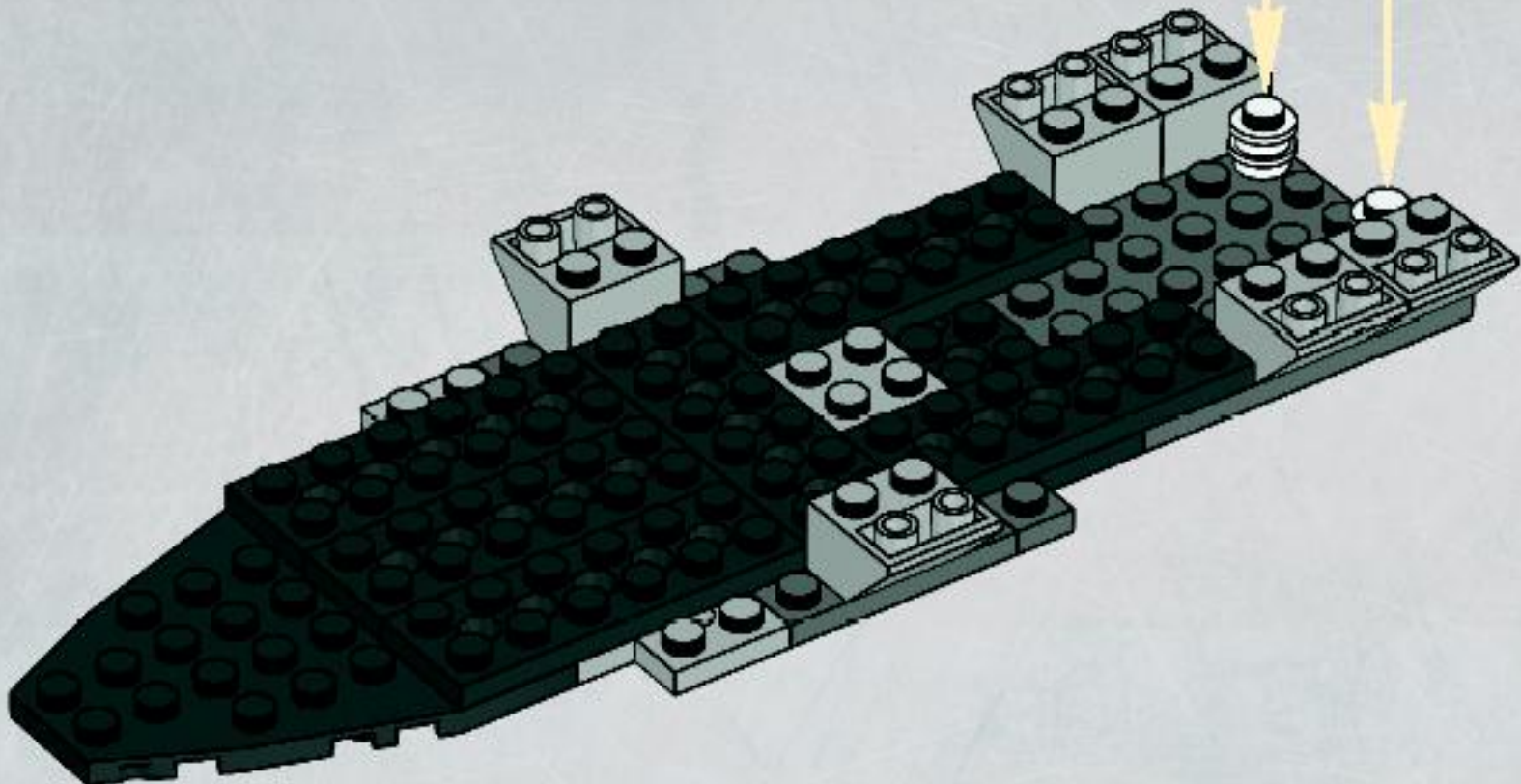



2x



1x

9

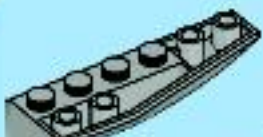
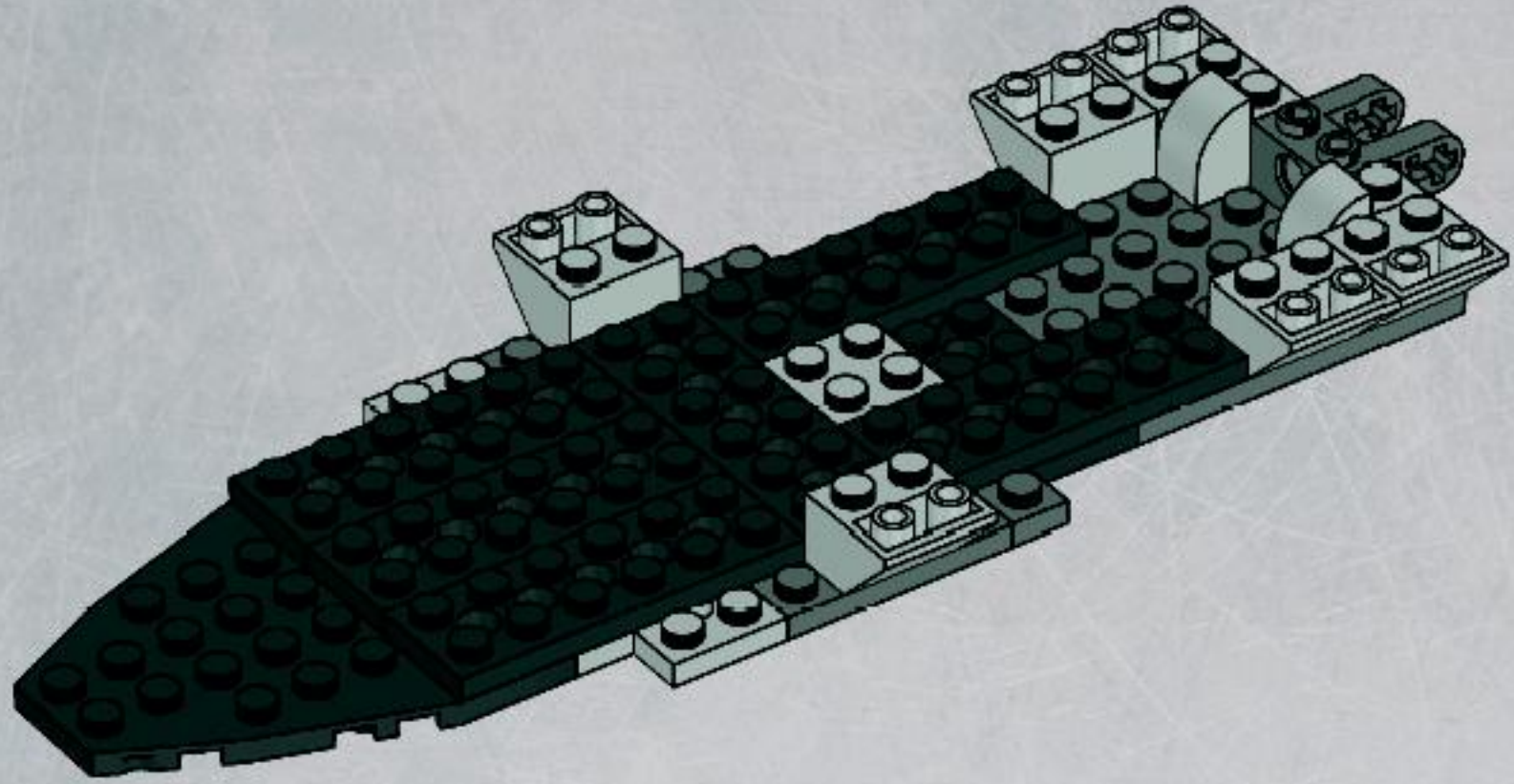

2x

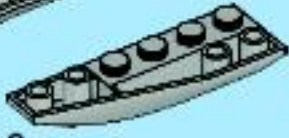

2x

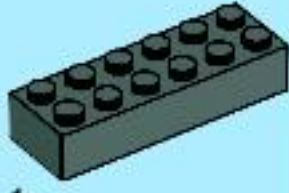

1x

10

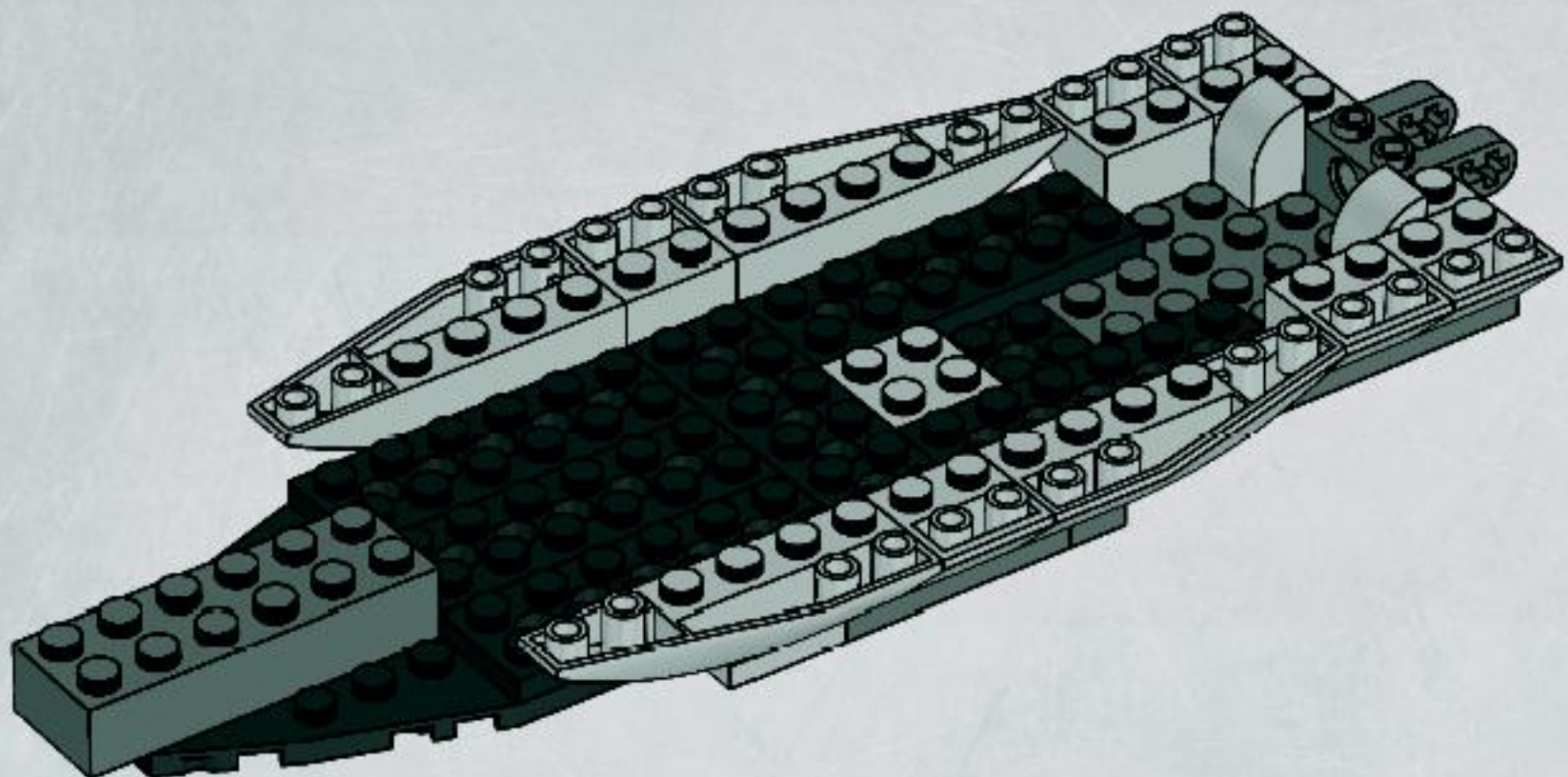

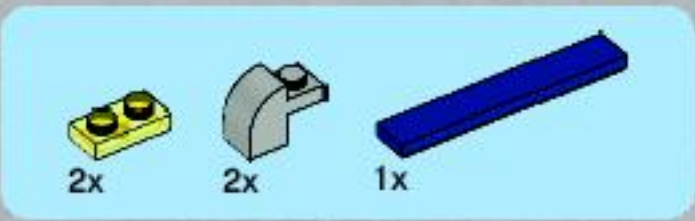

11

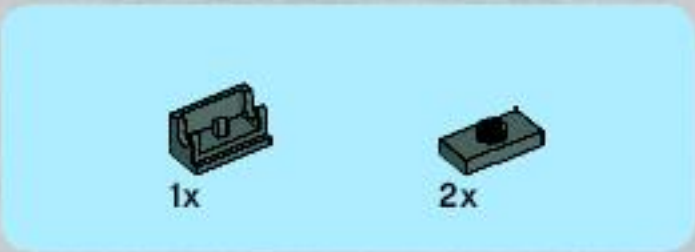
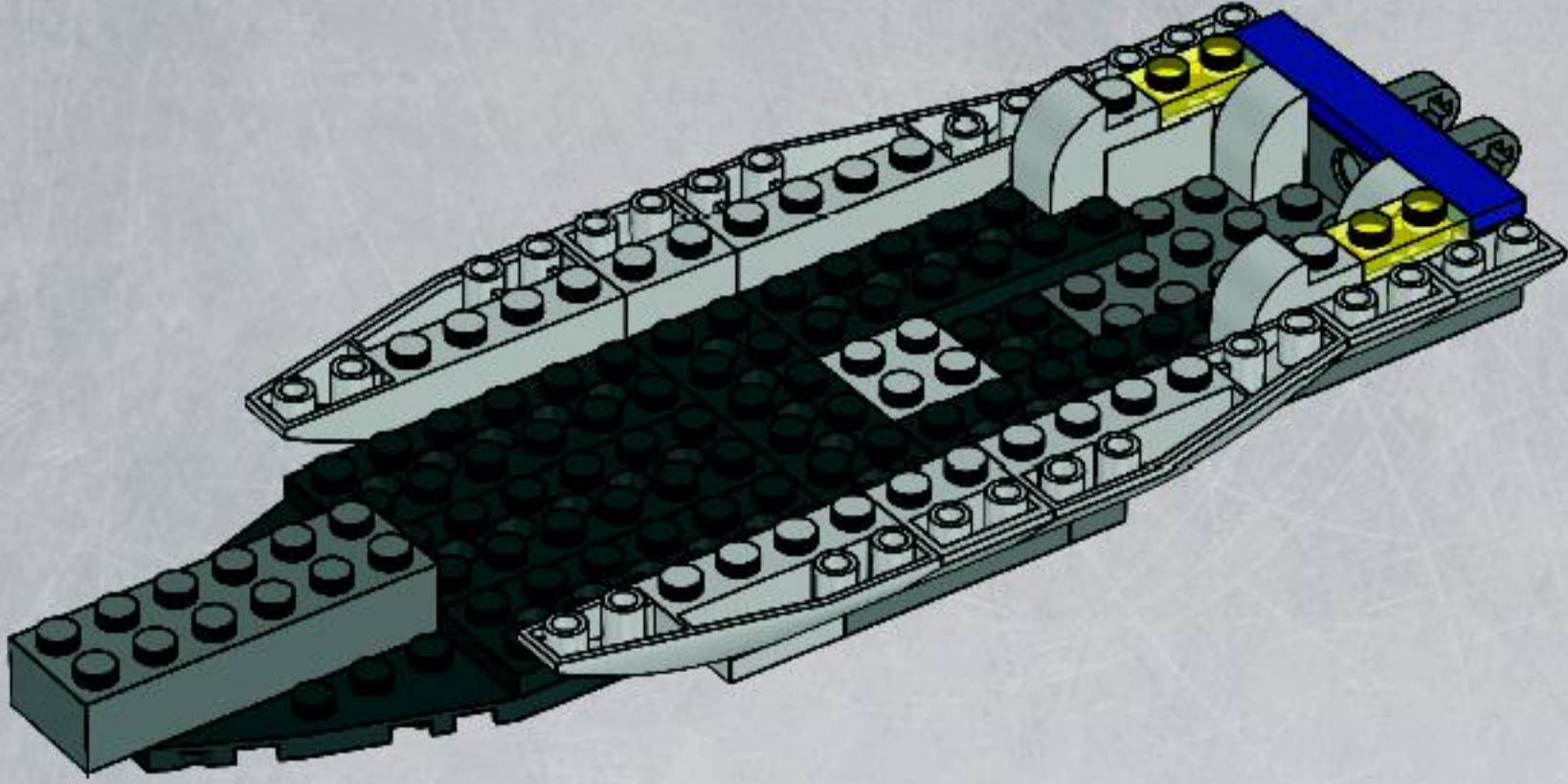

12

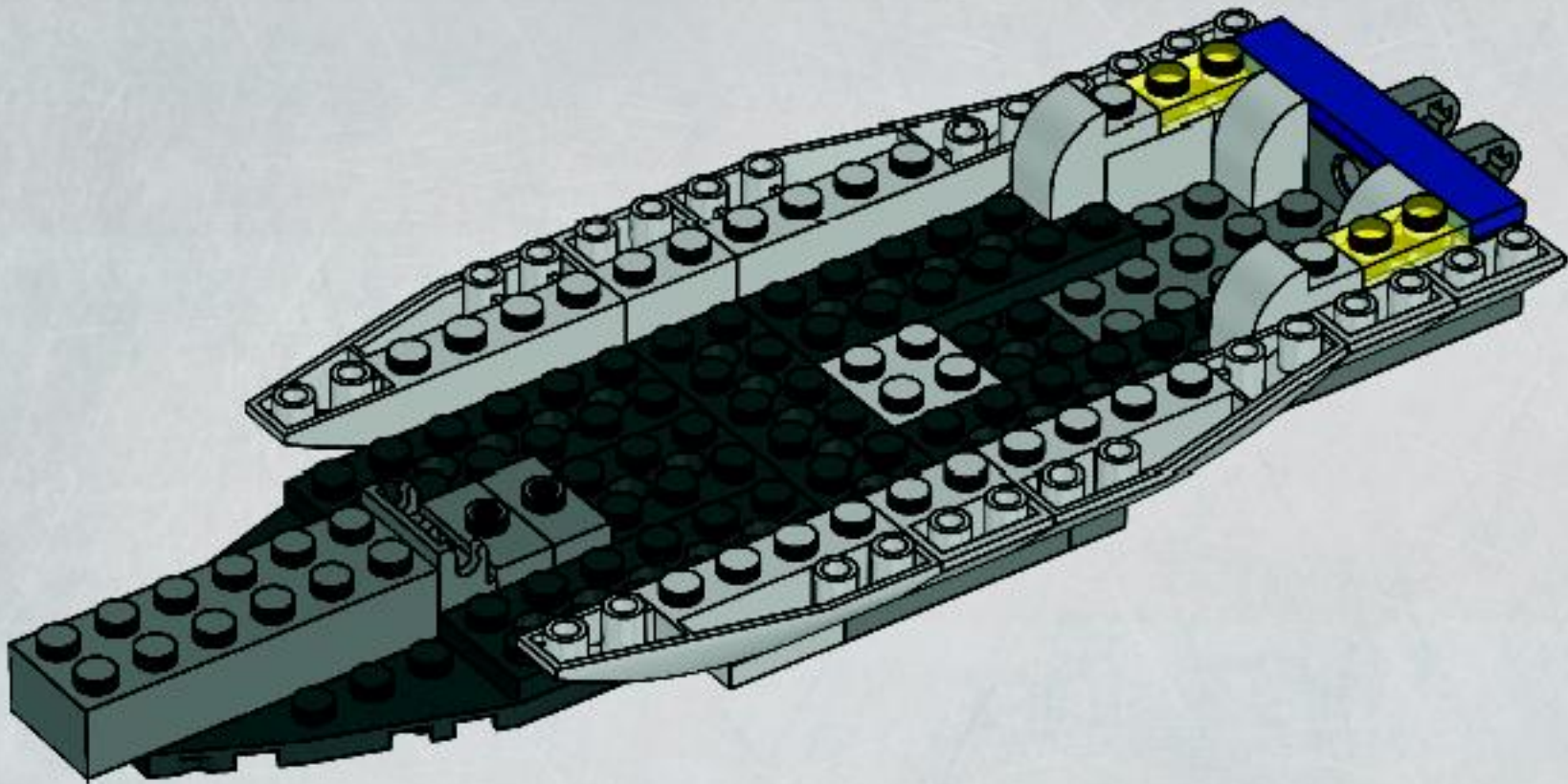

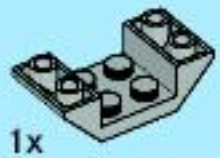

1x



1x

13

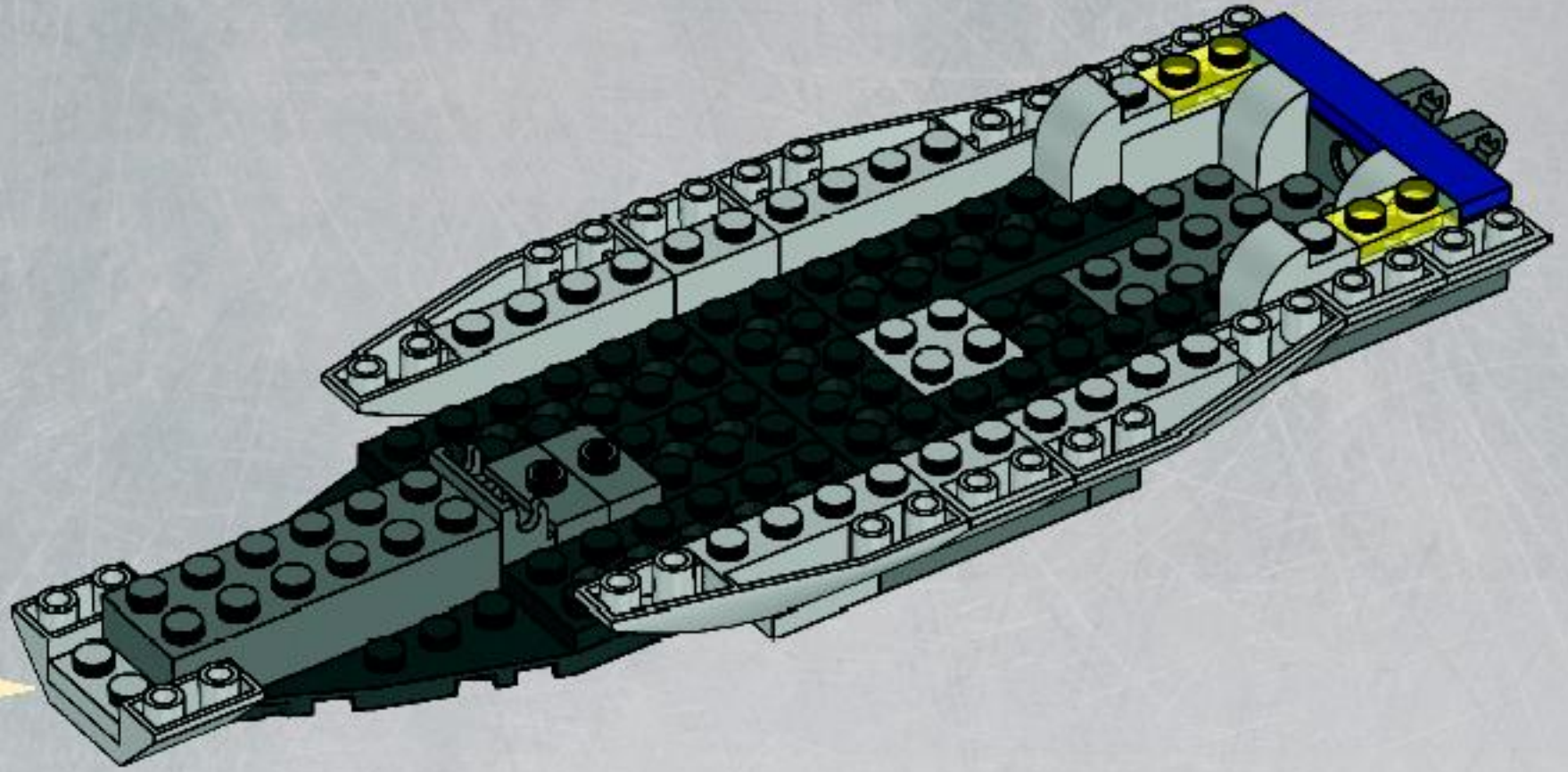
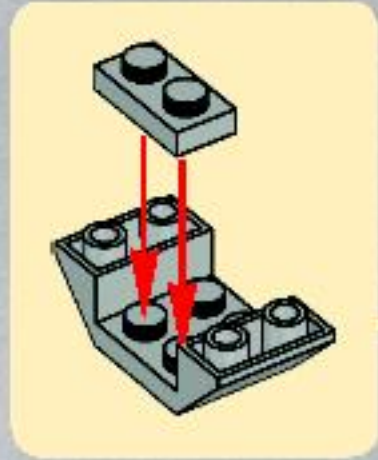

4x

14

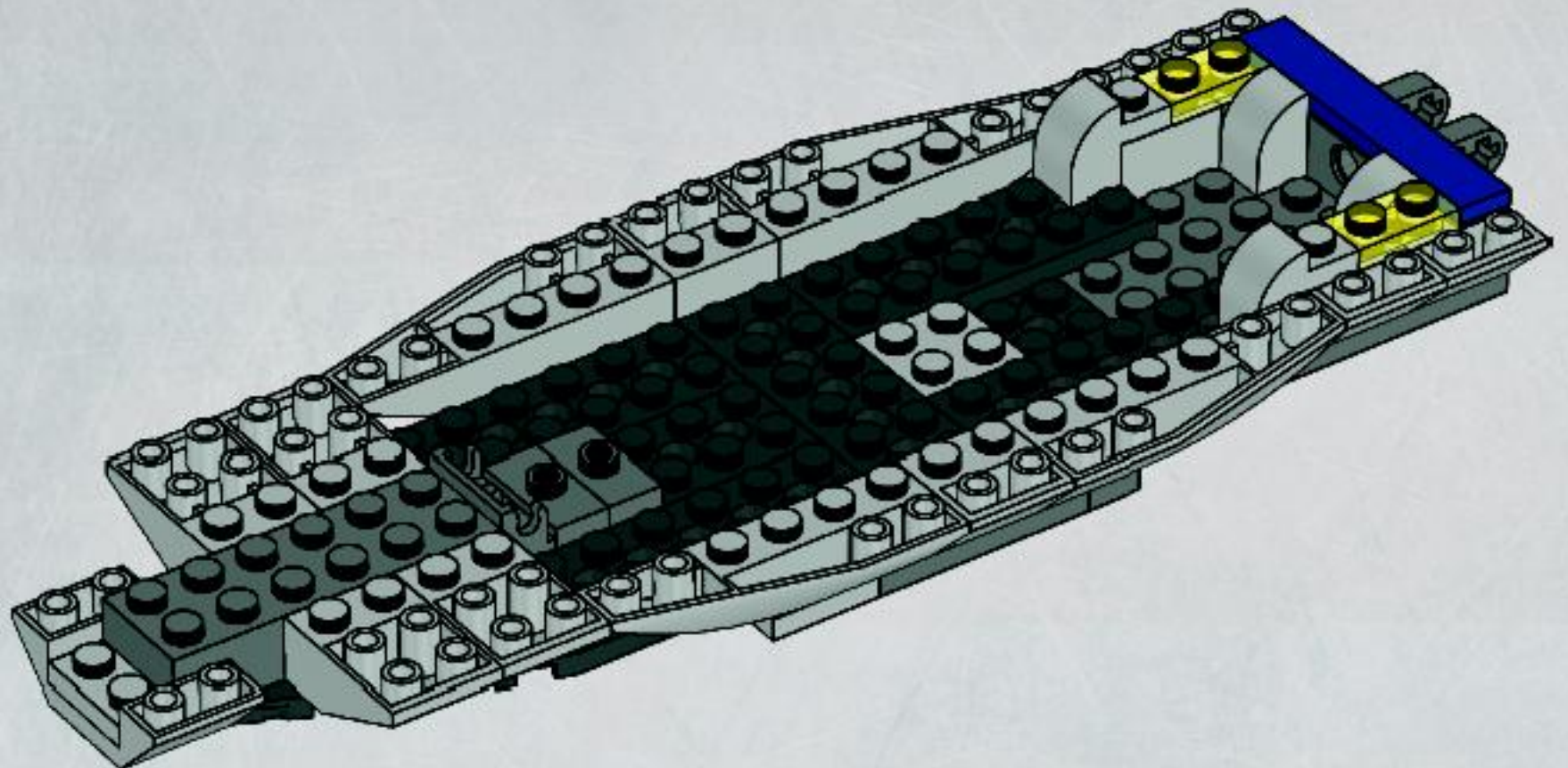



1x



2x

15

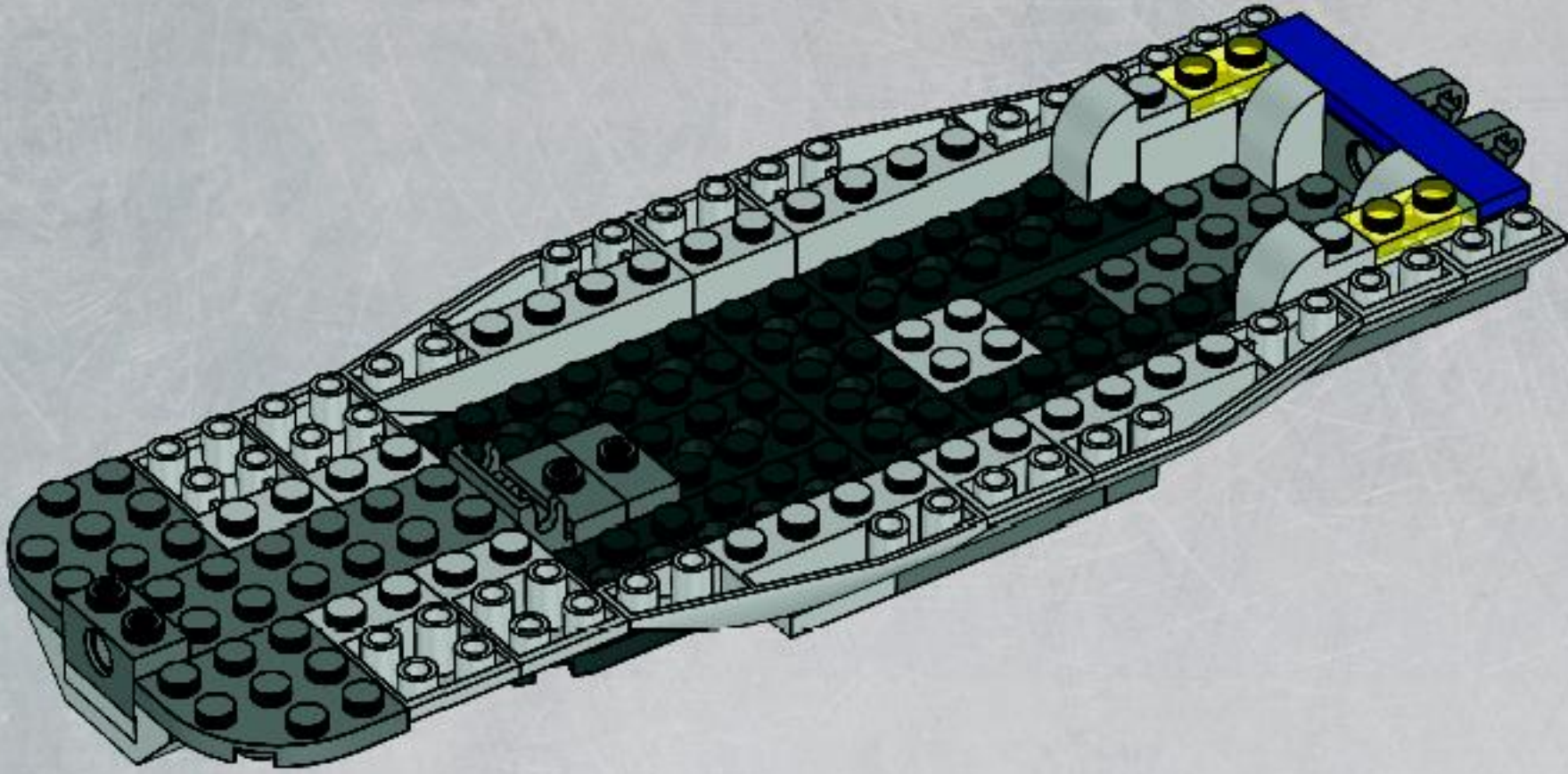

2x



1x



1x

16

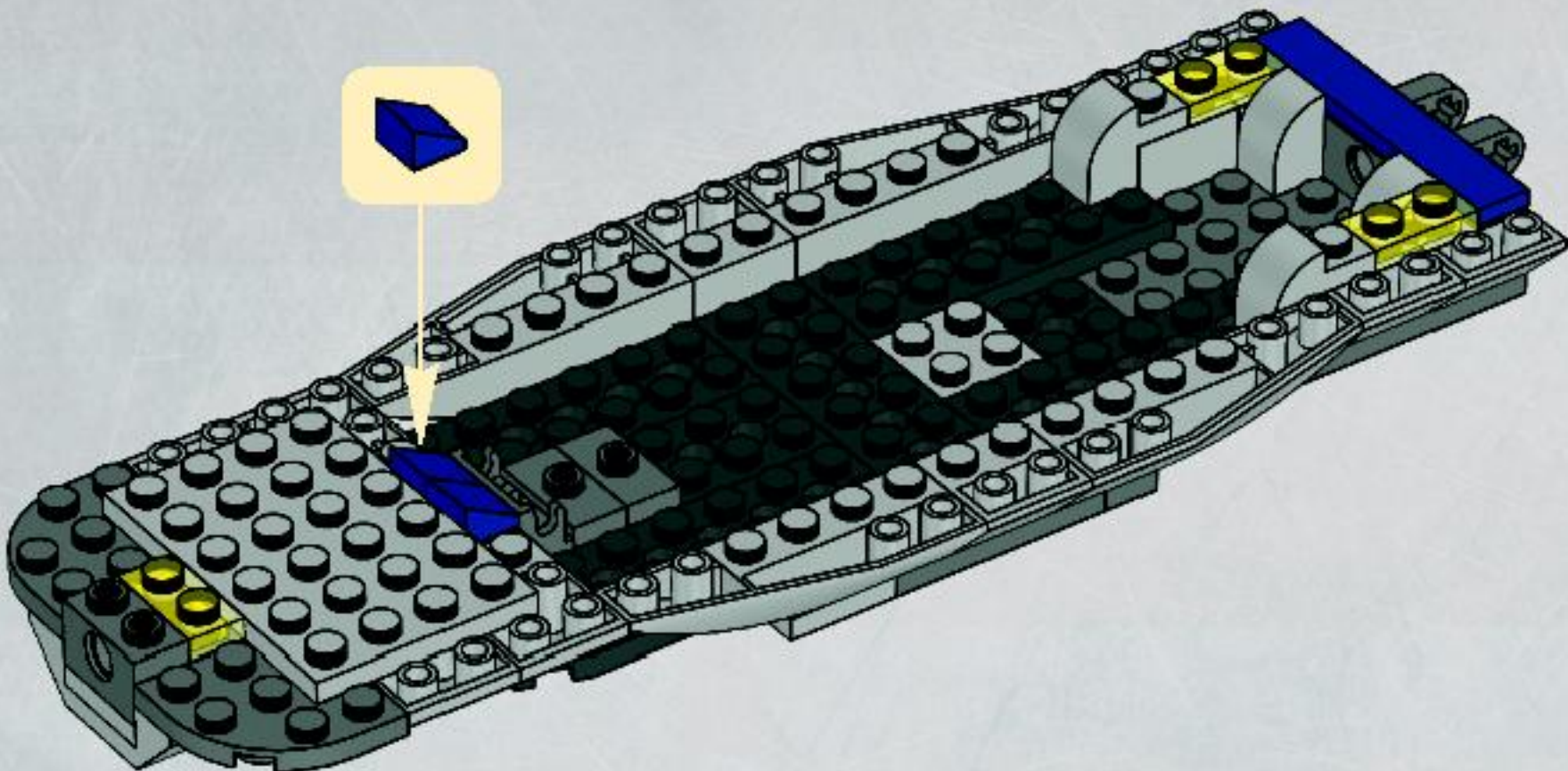



2x



1x



1x

17

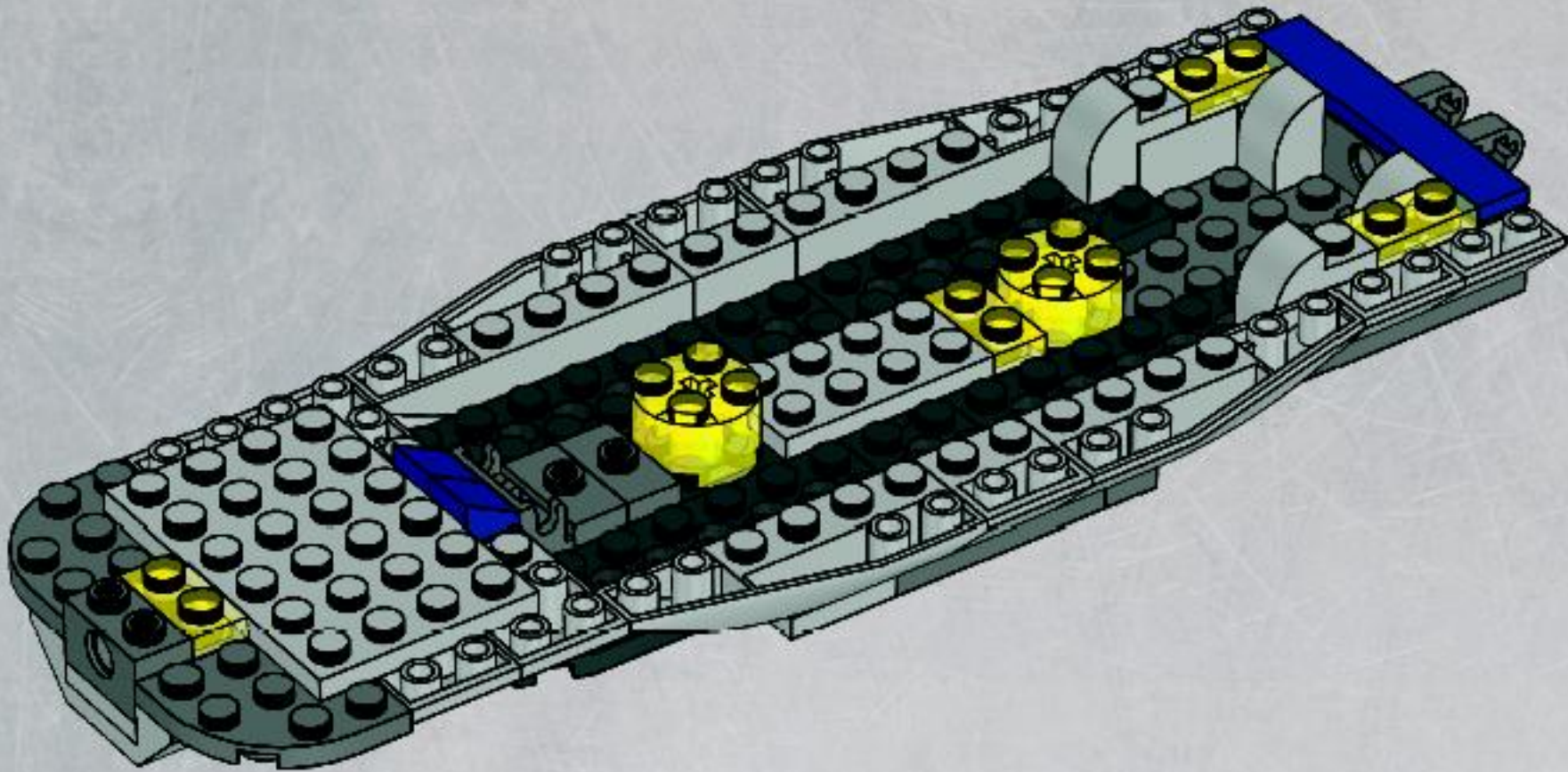

4x



1x



2x



2x

18

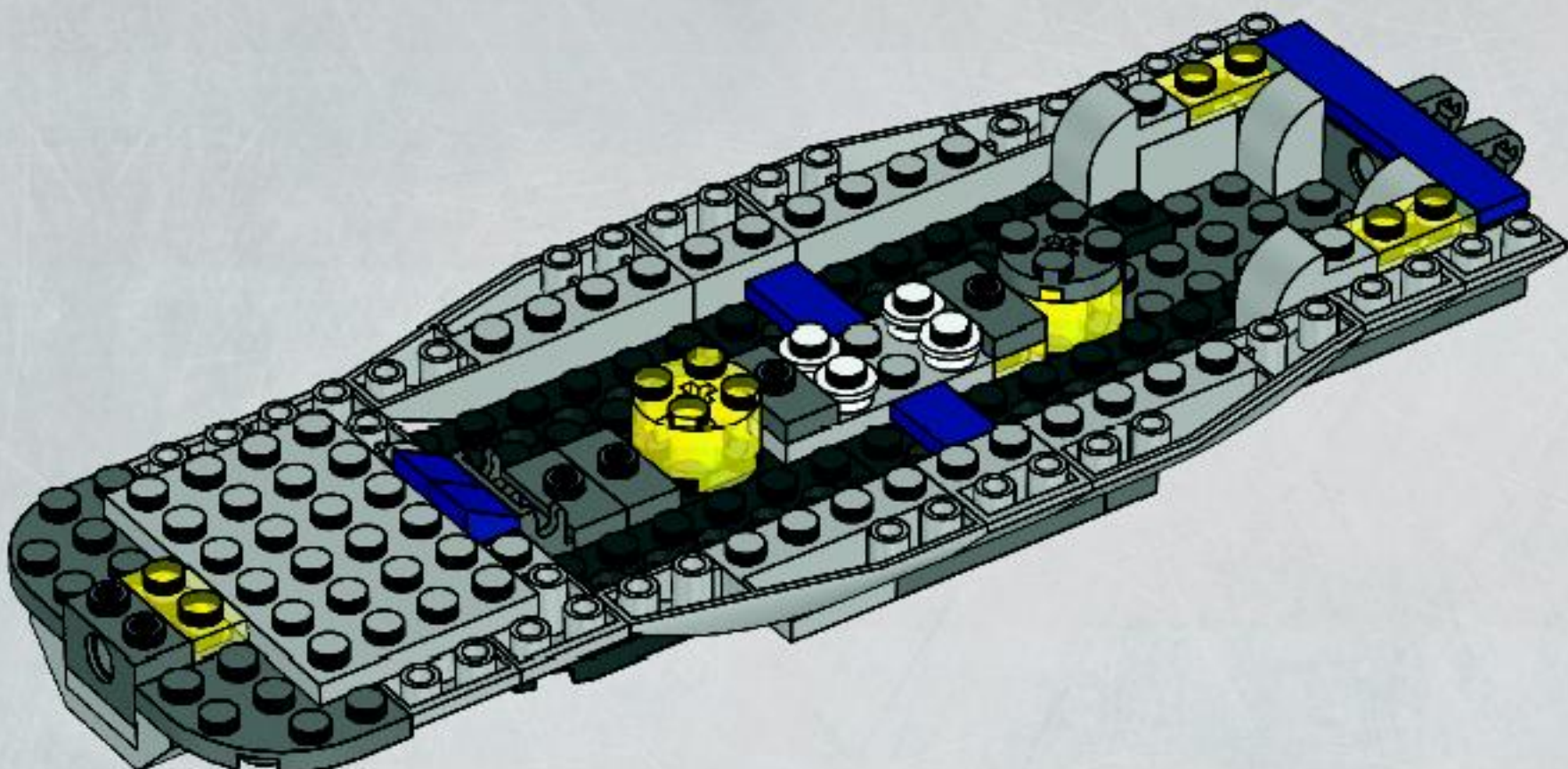



2x



2x



2x

19

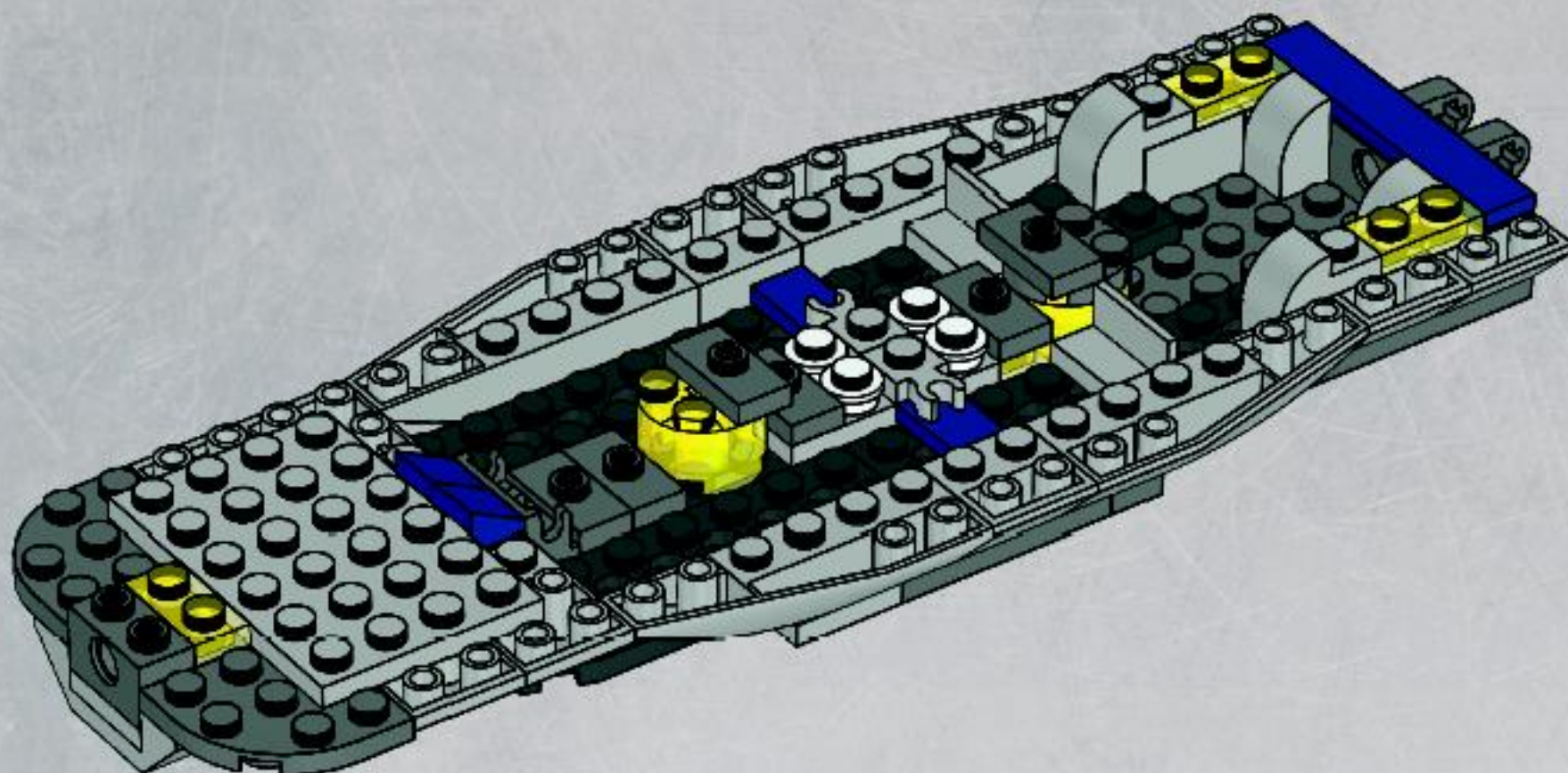

1x

20

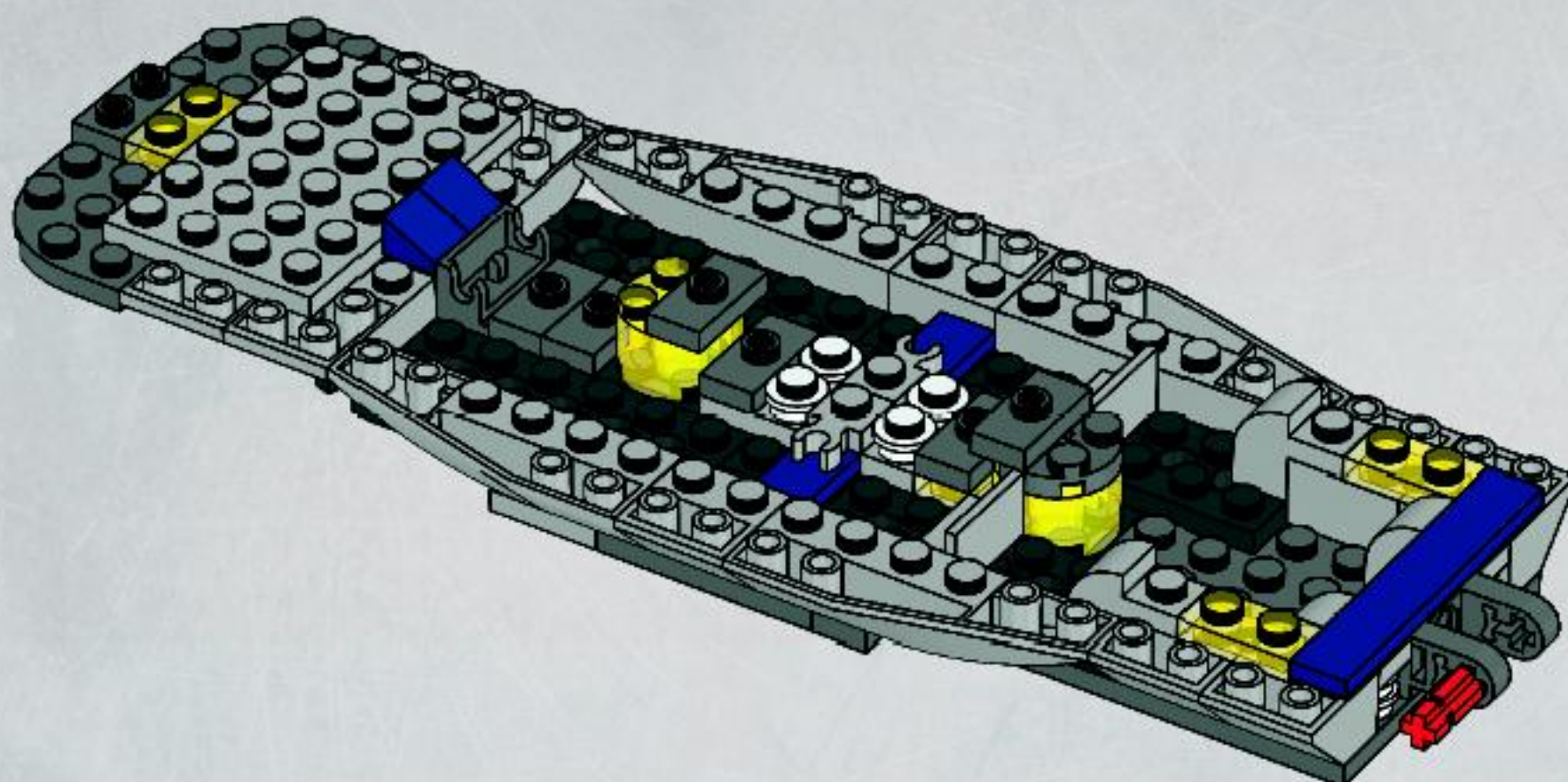

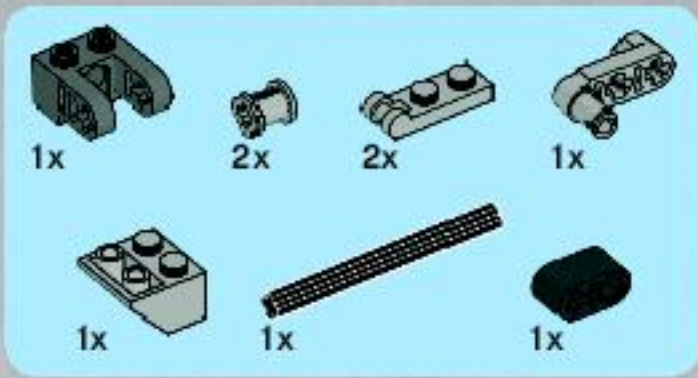

21

1

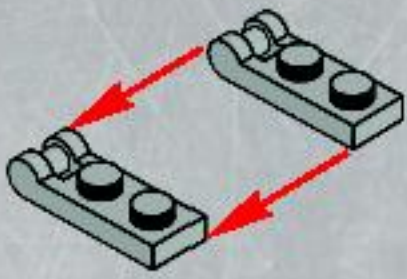

2

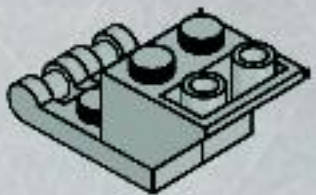

3

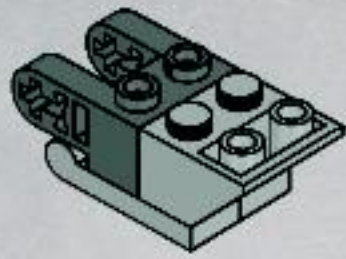

4

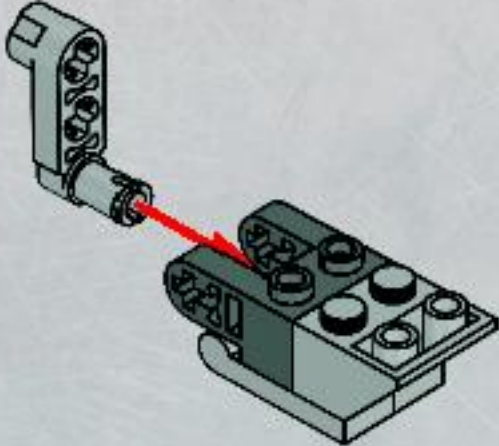

5

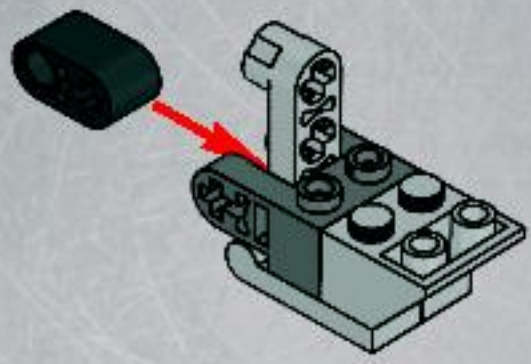

6

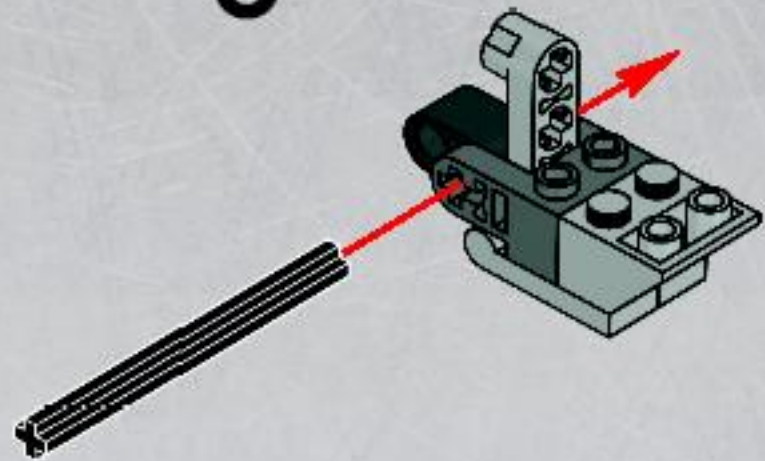

7

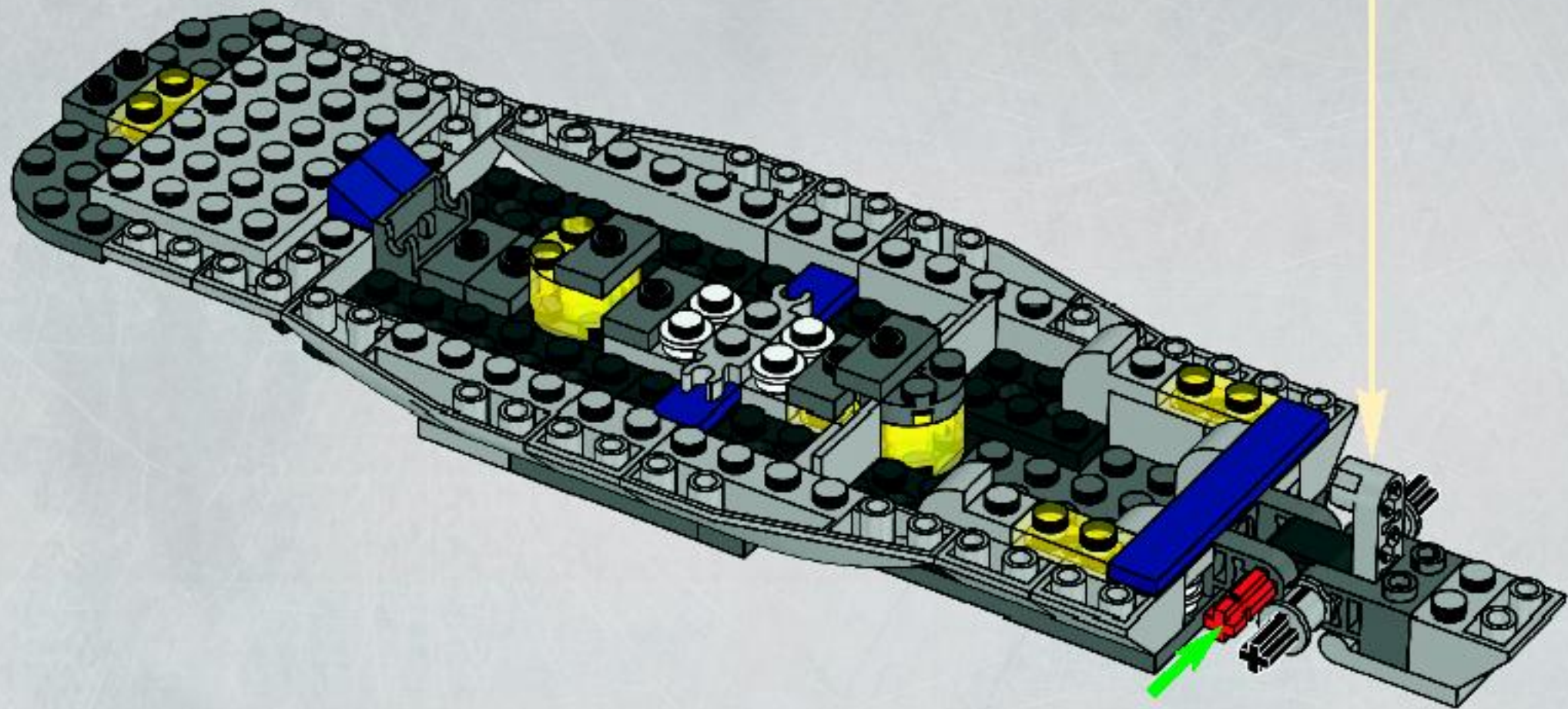
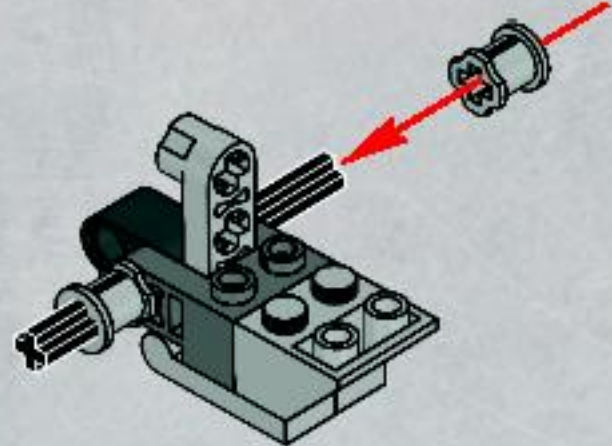

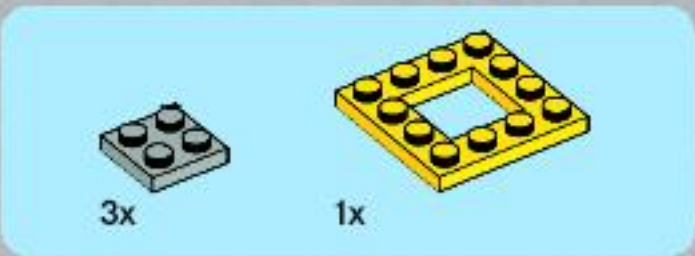

22

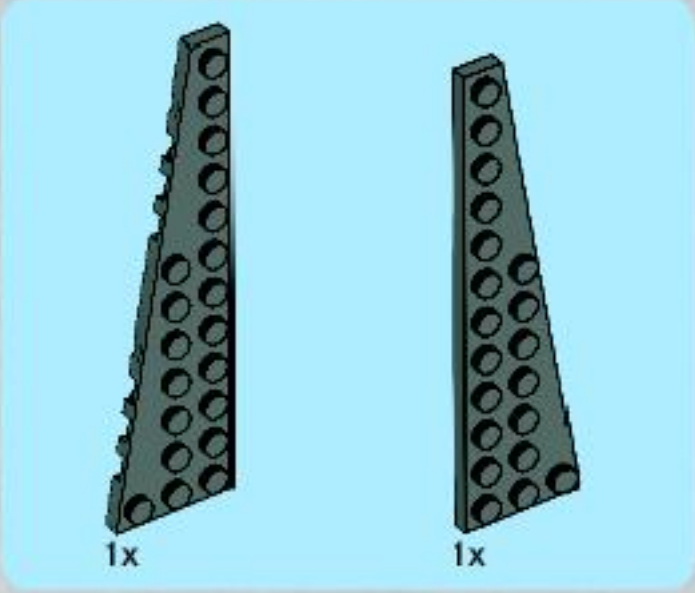
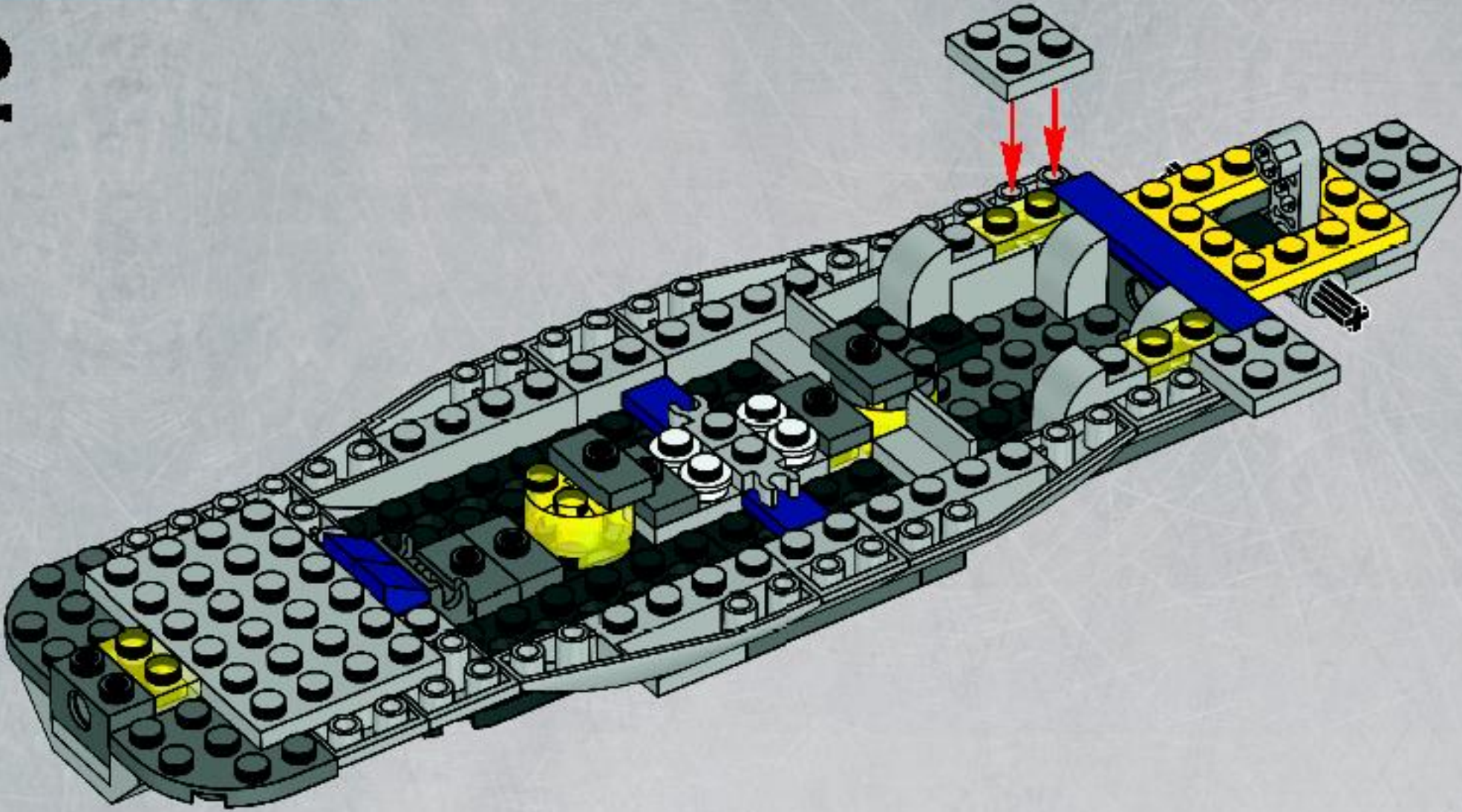

23

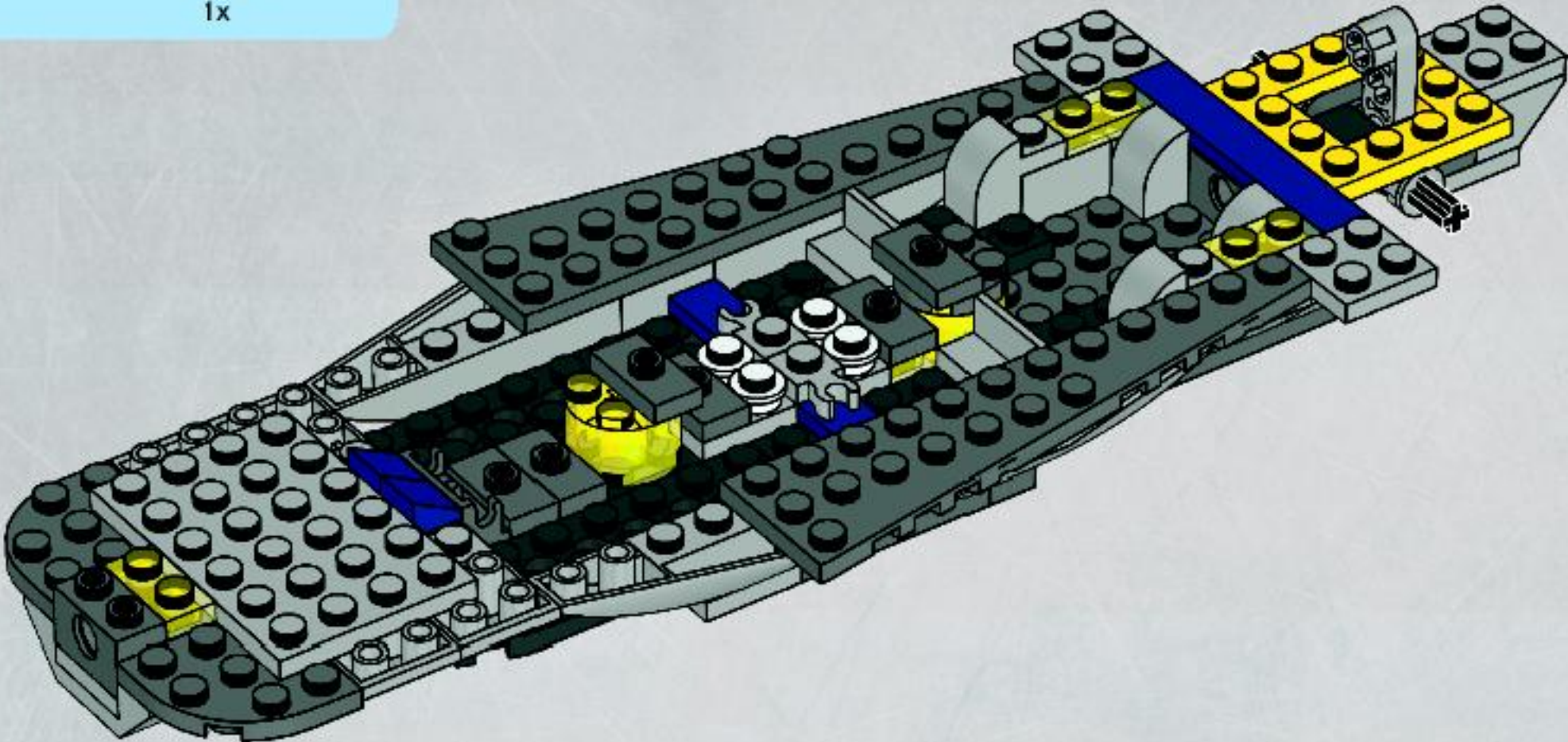

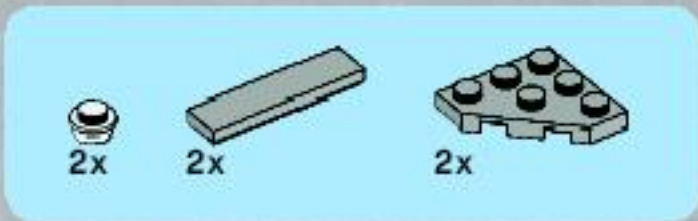

24

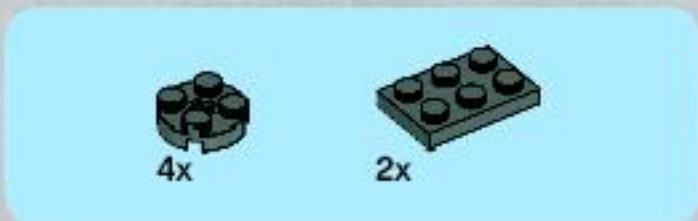
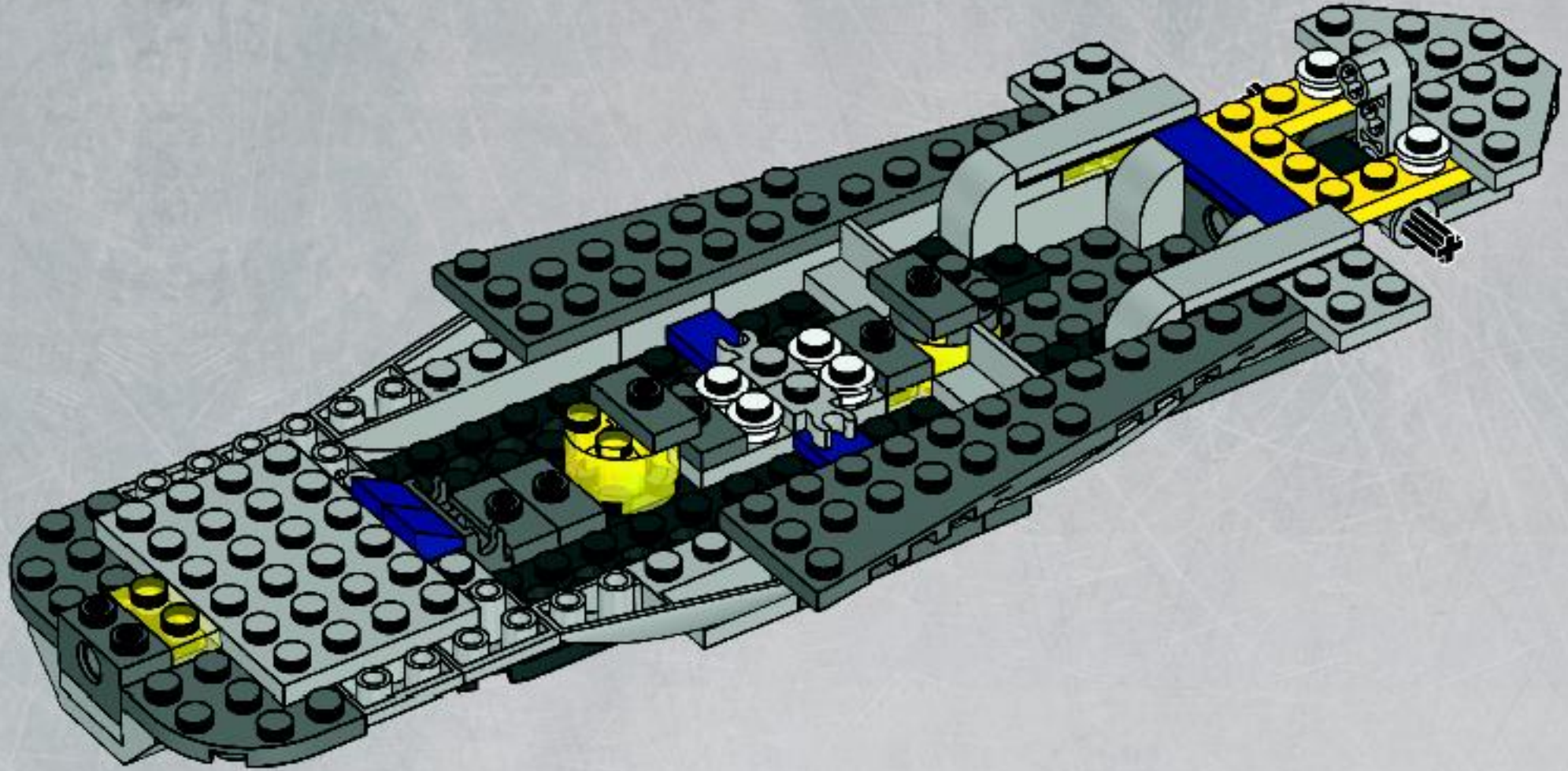

25

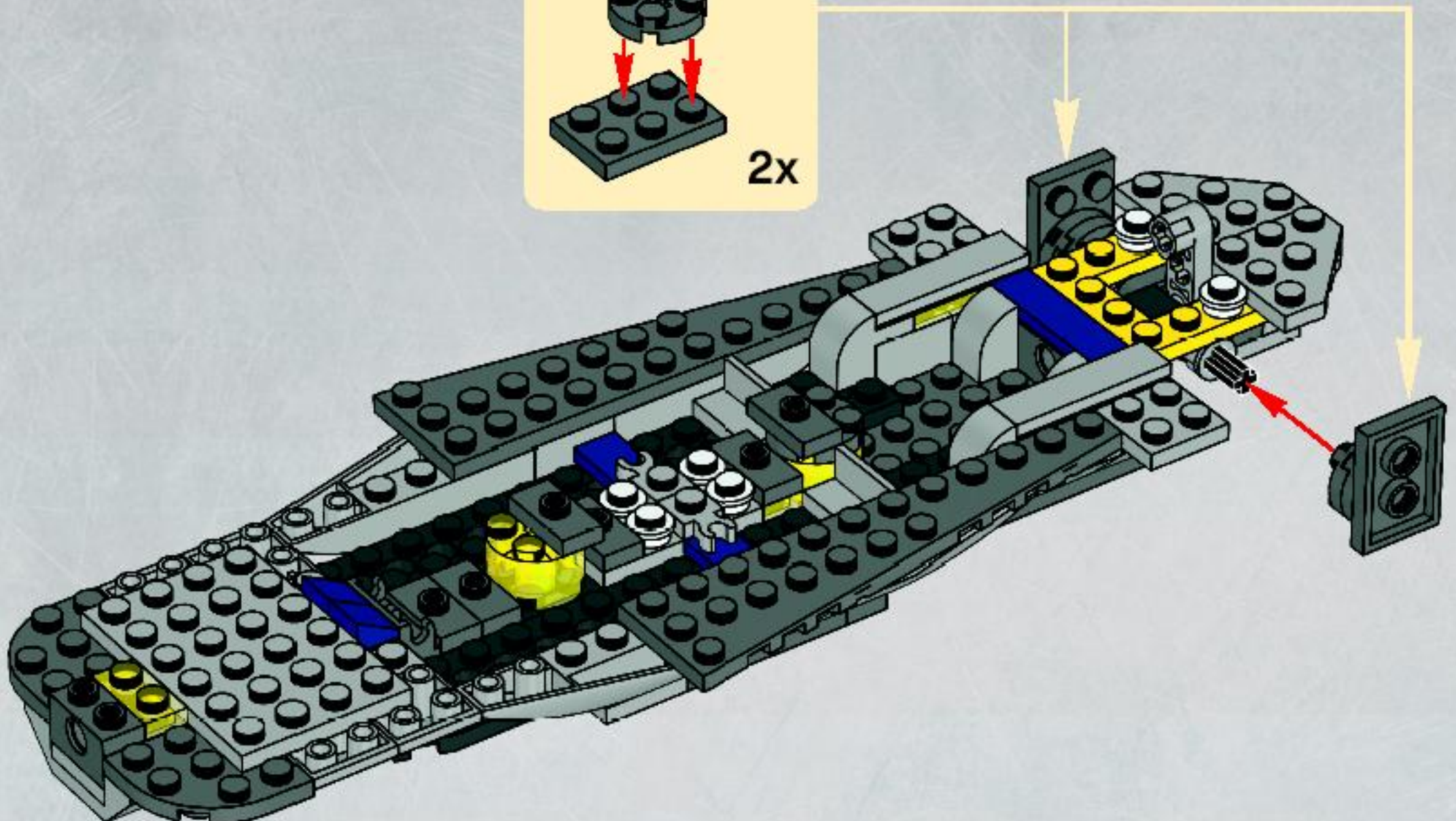
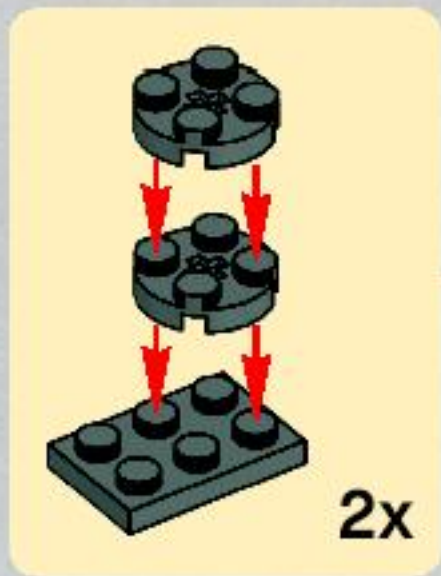



4x



1x



2x

26

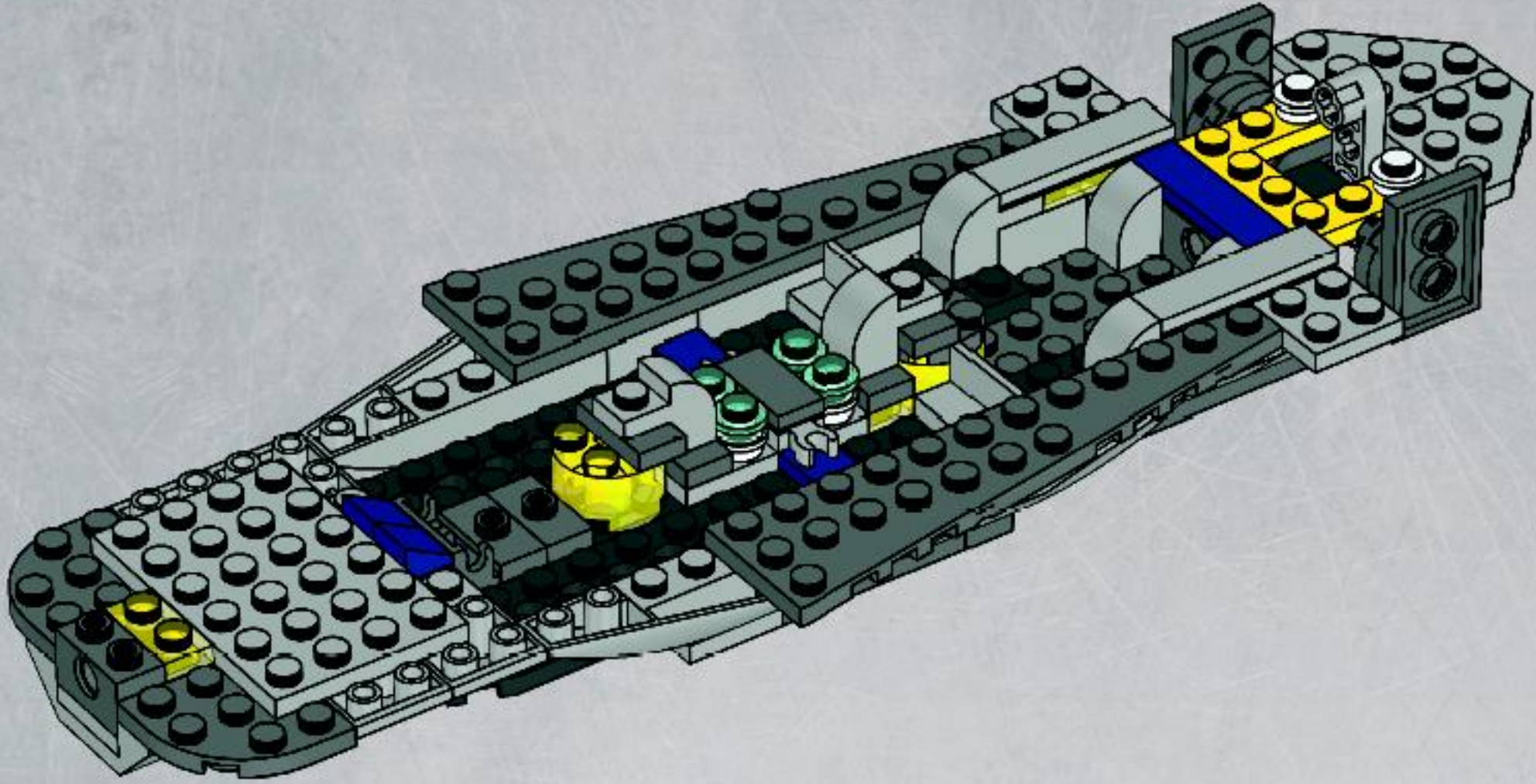

2x



2x



2x

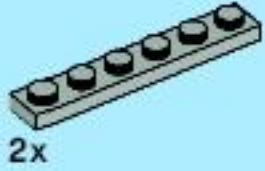

2x

27

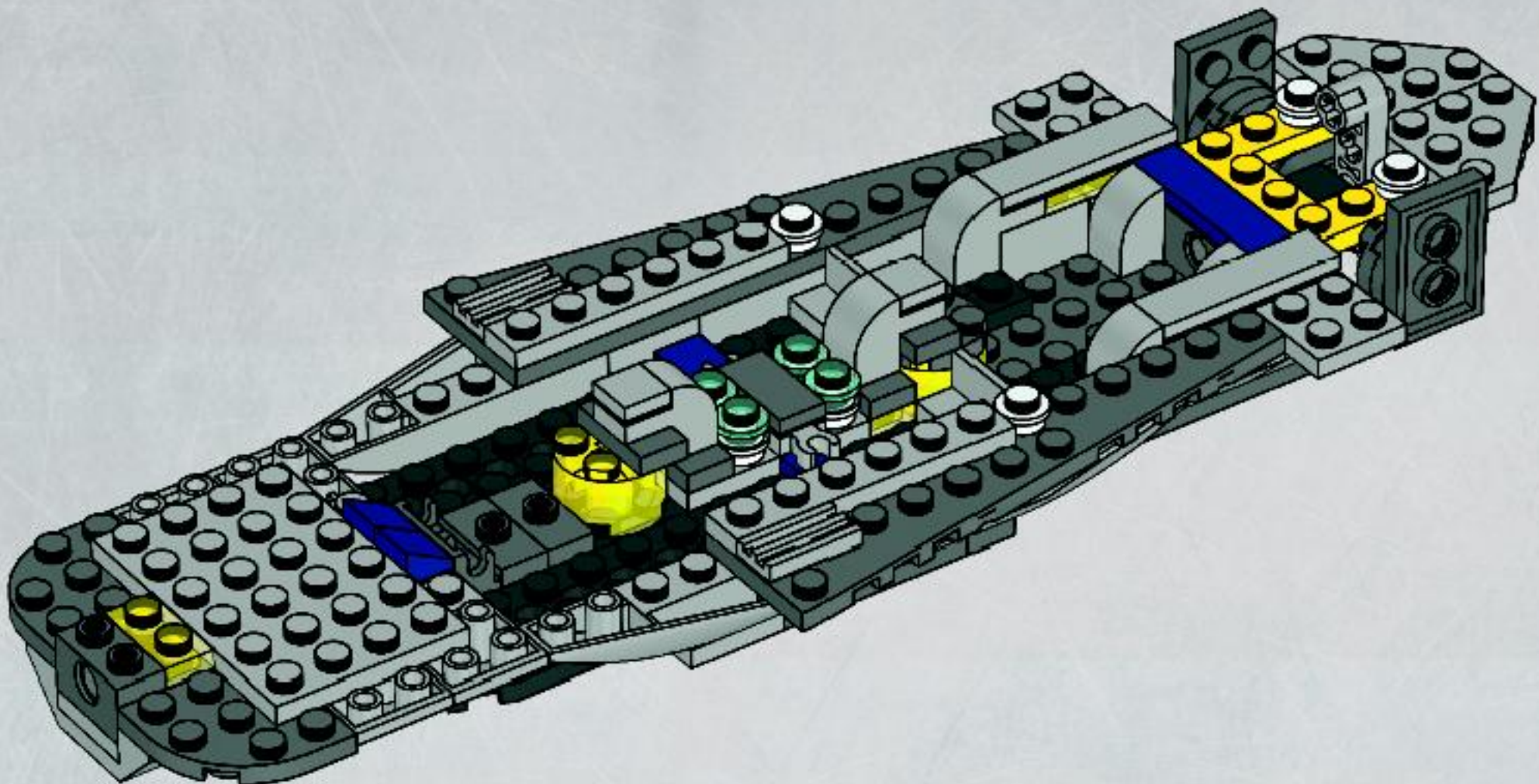

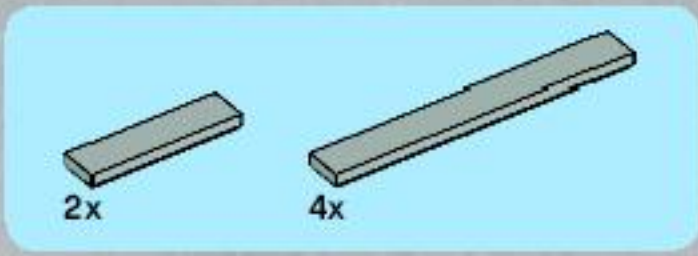

28

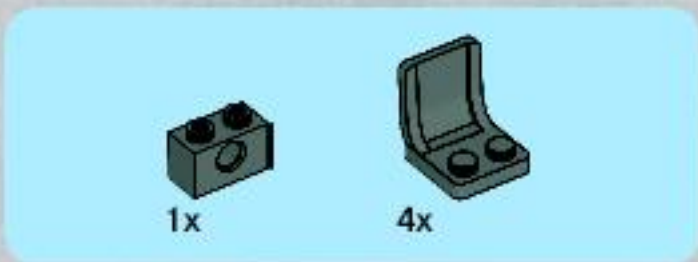
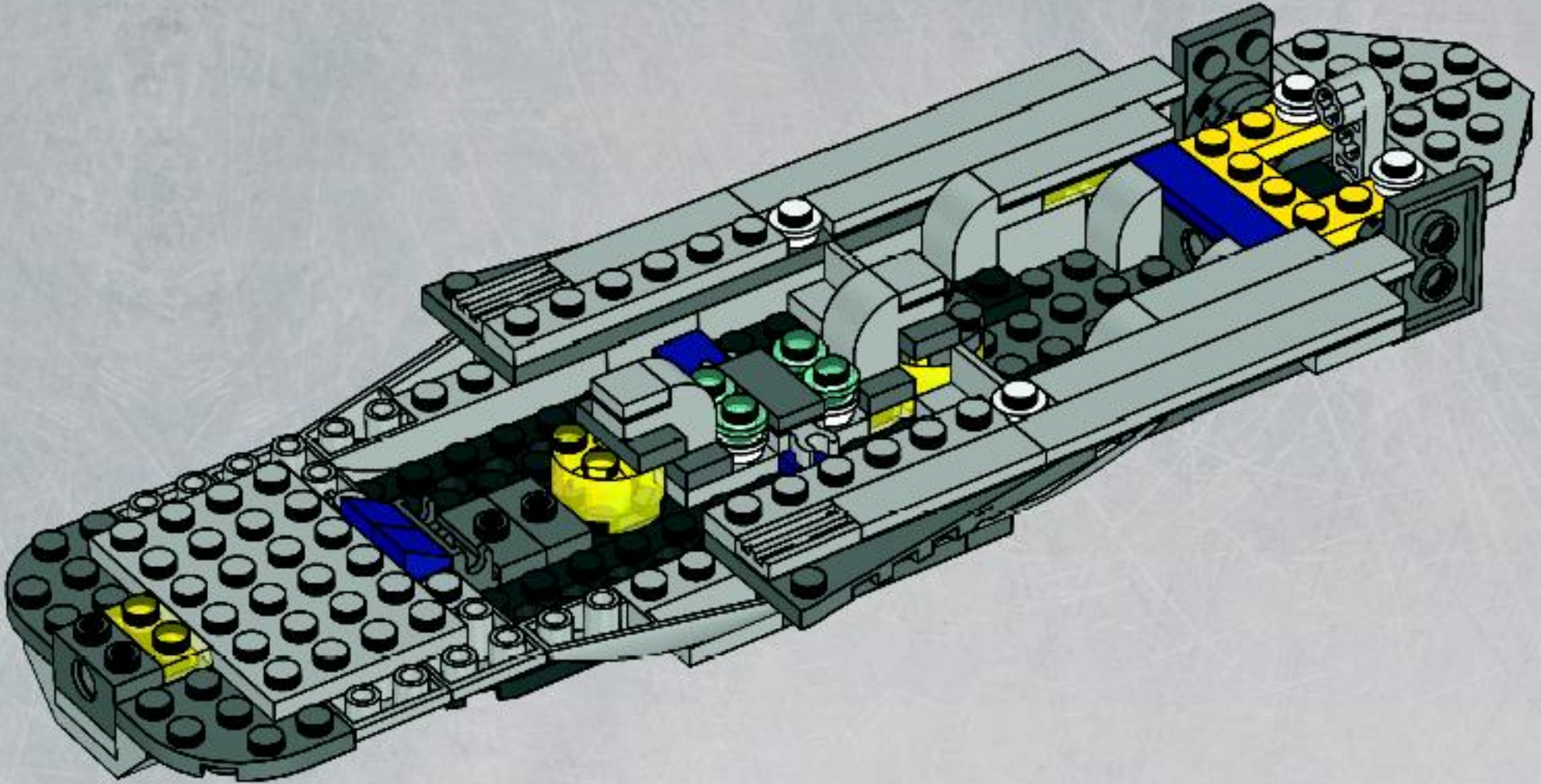

29

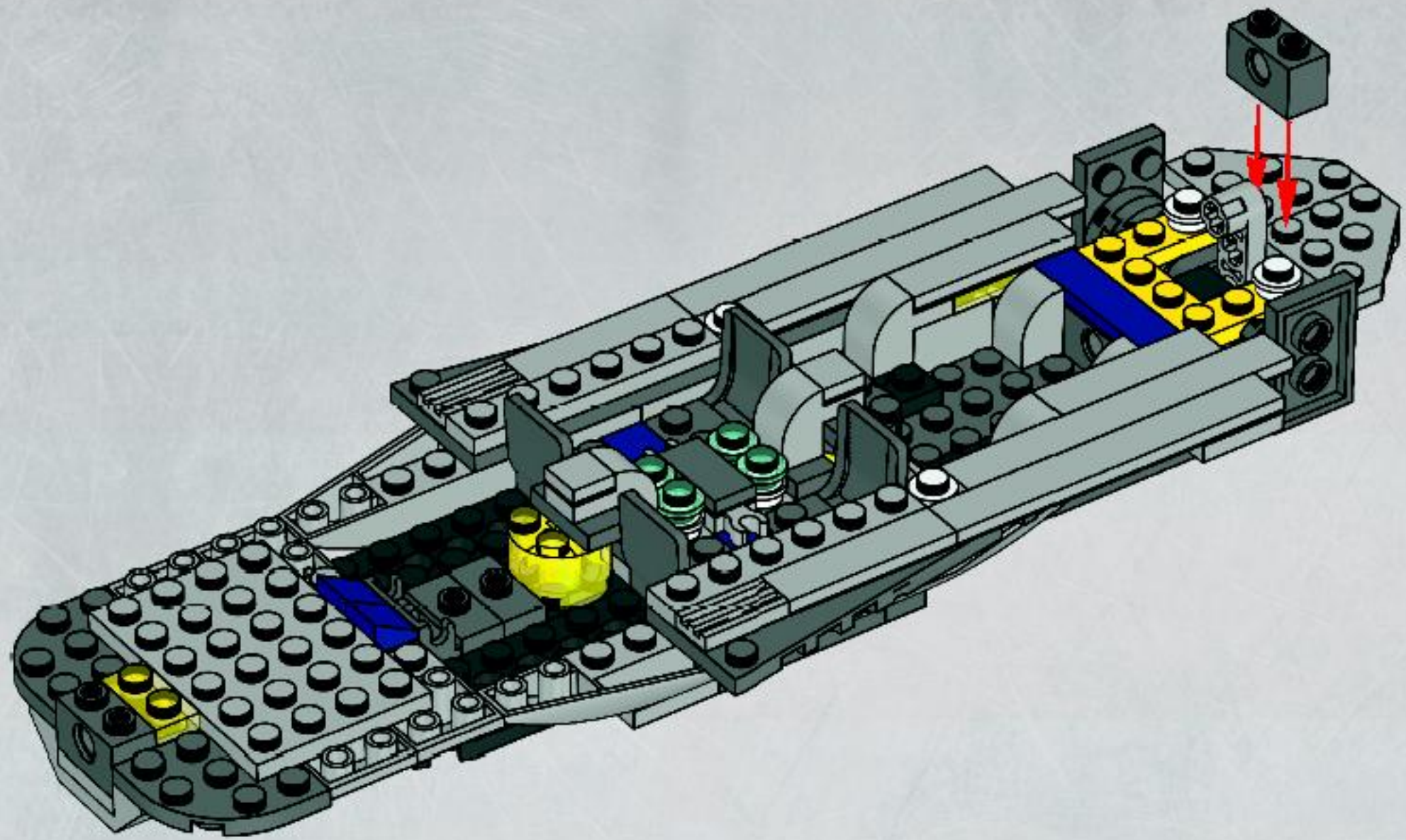



30

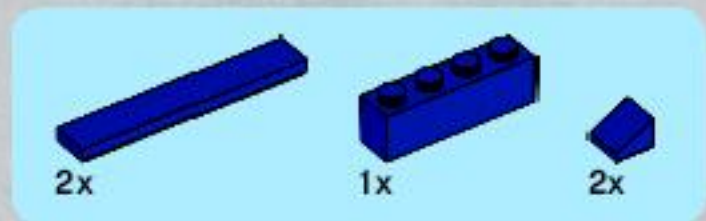
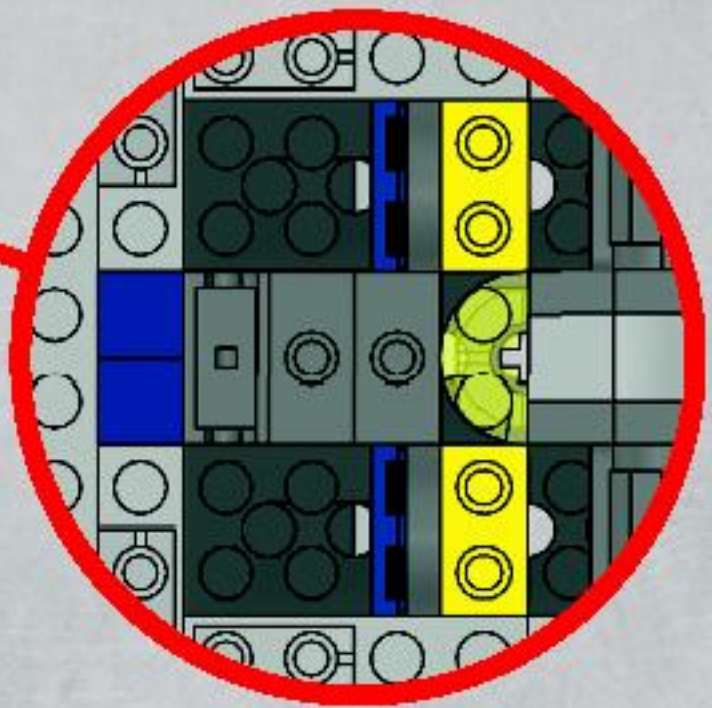
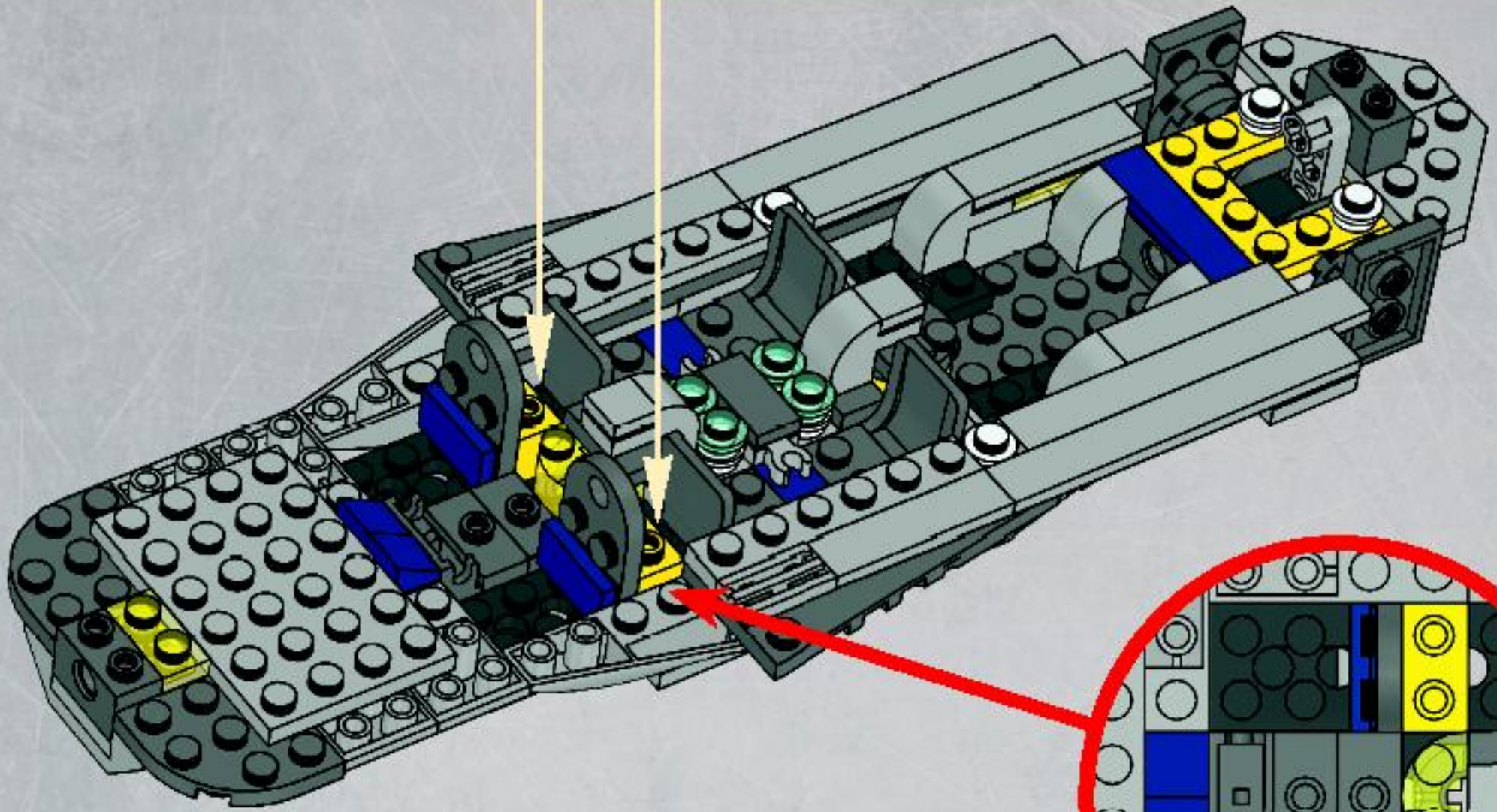
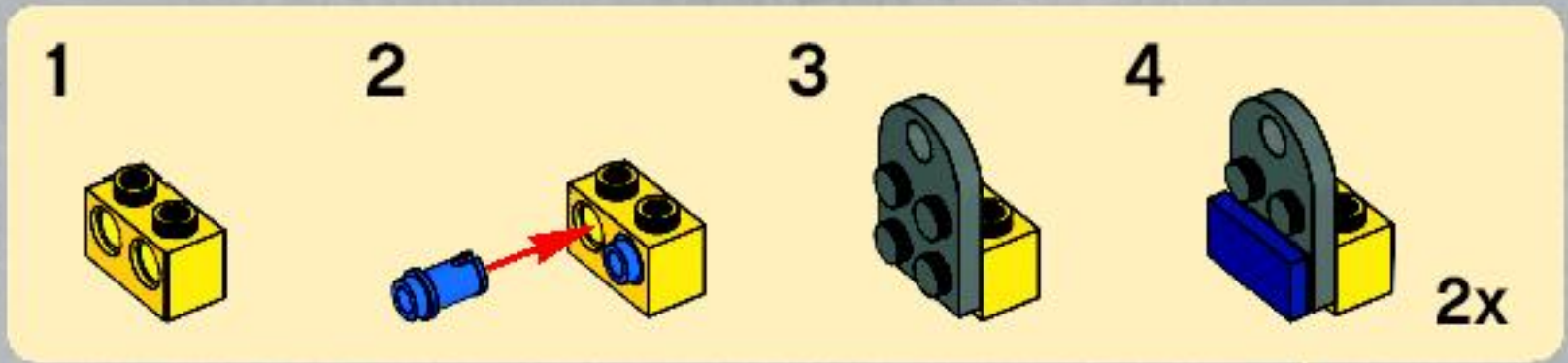

31

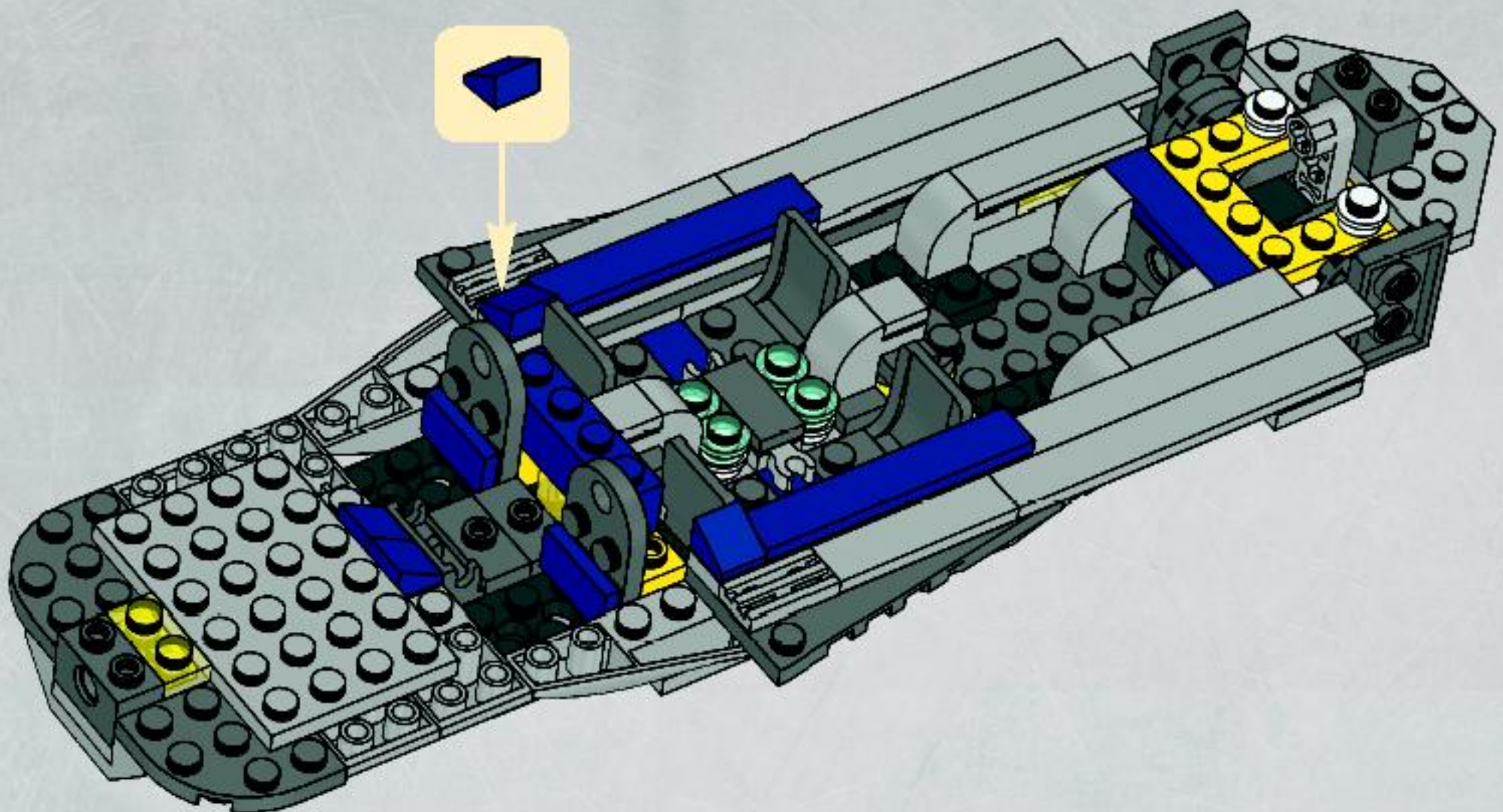



2x



1x

32

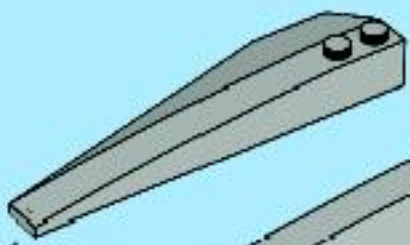
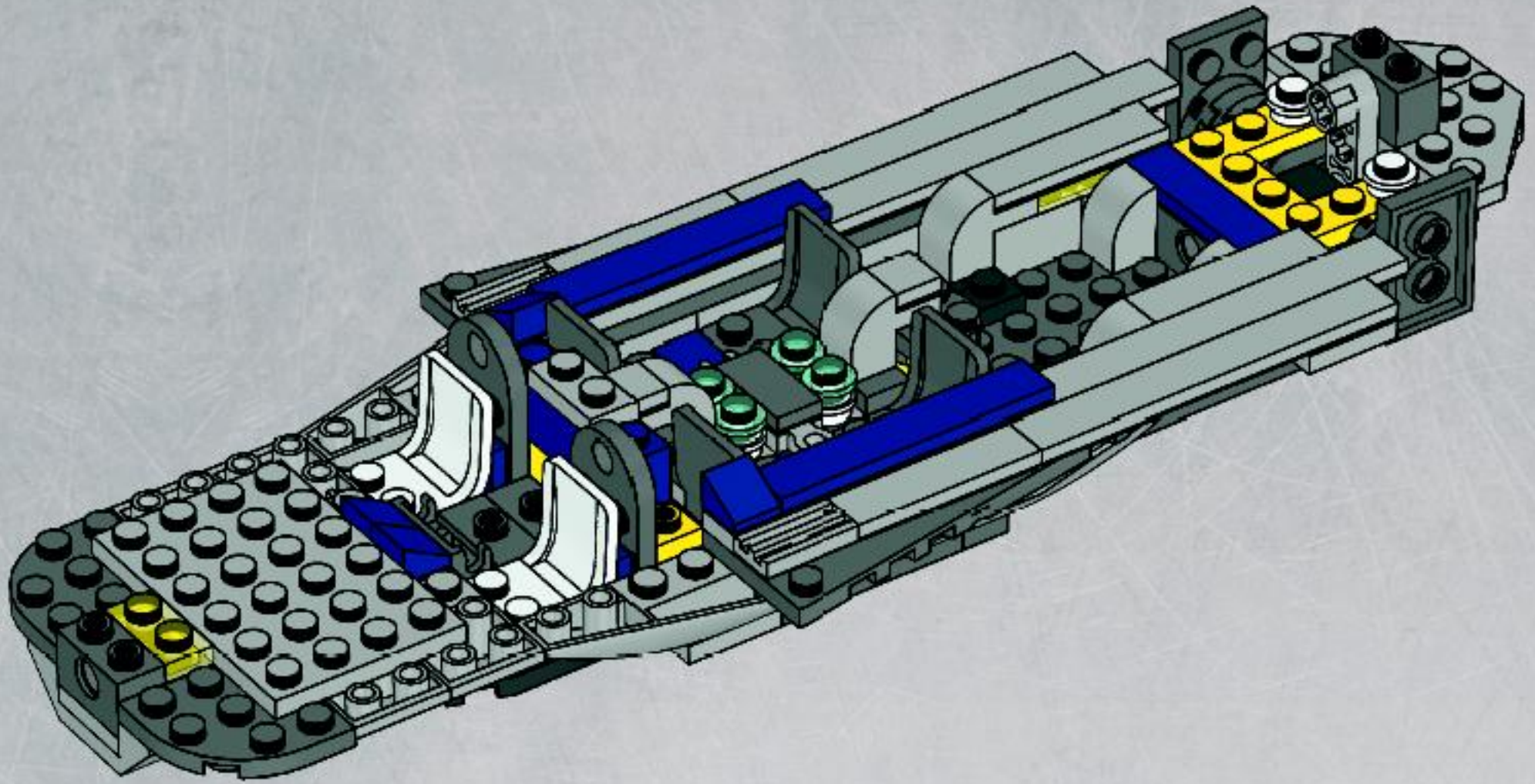

1x

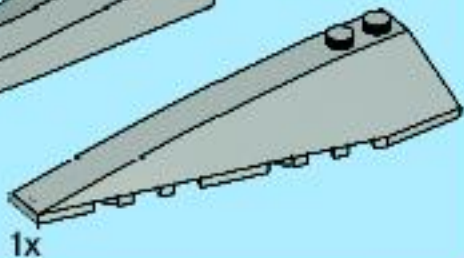

1x

33

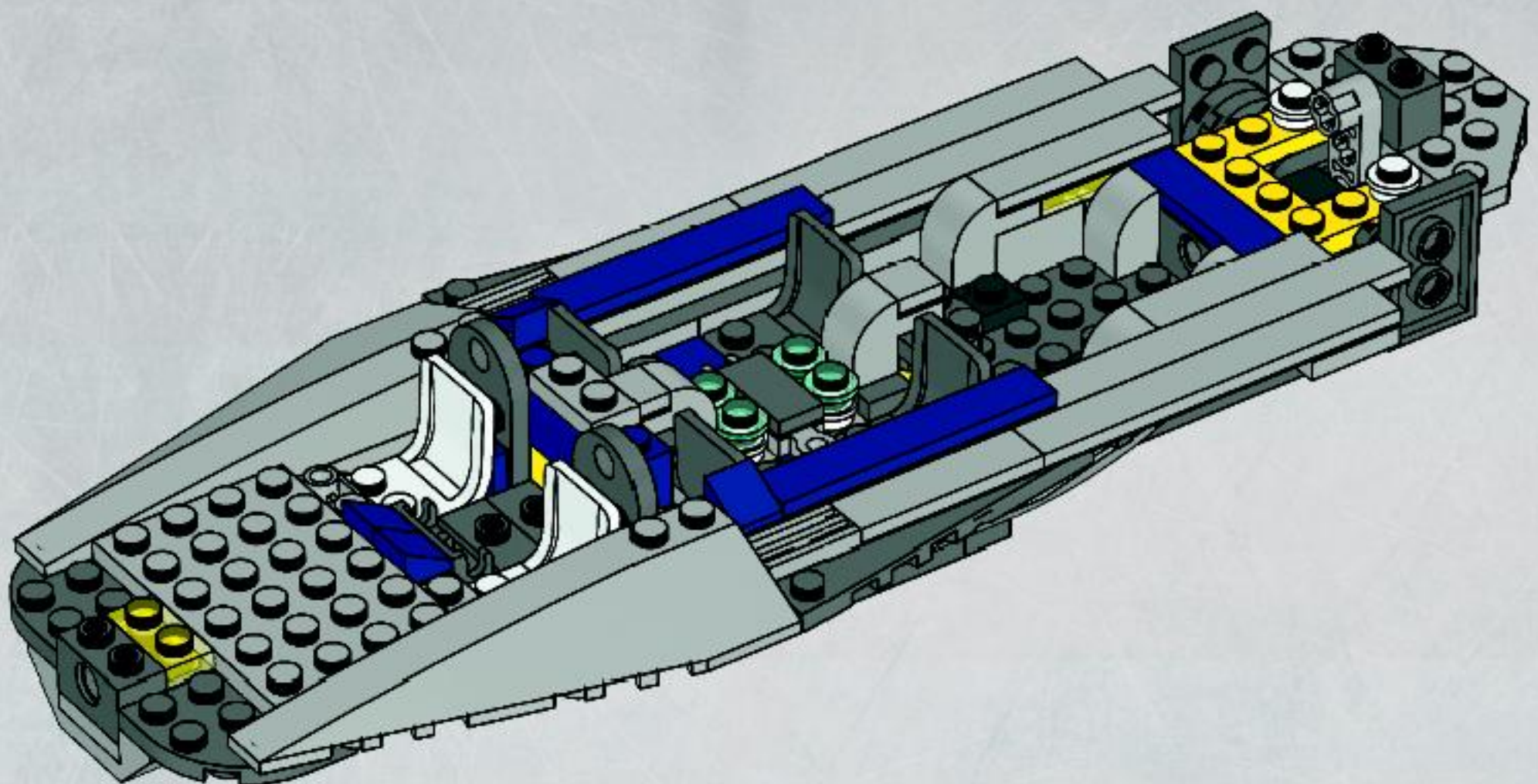



2x



1x



2x

34

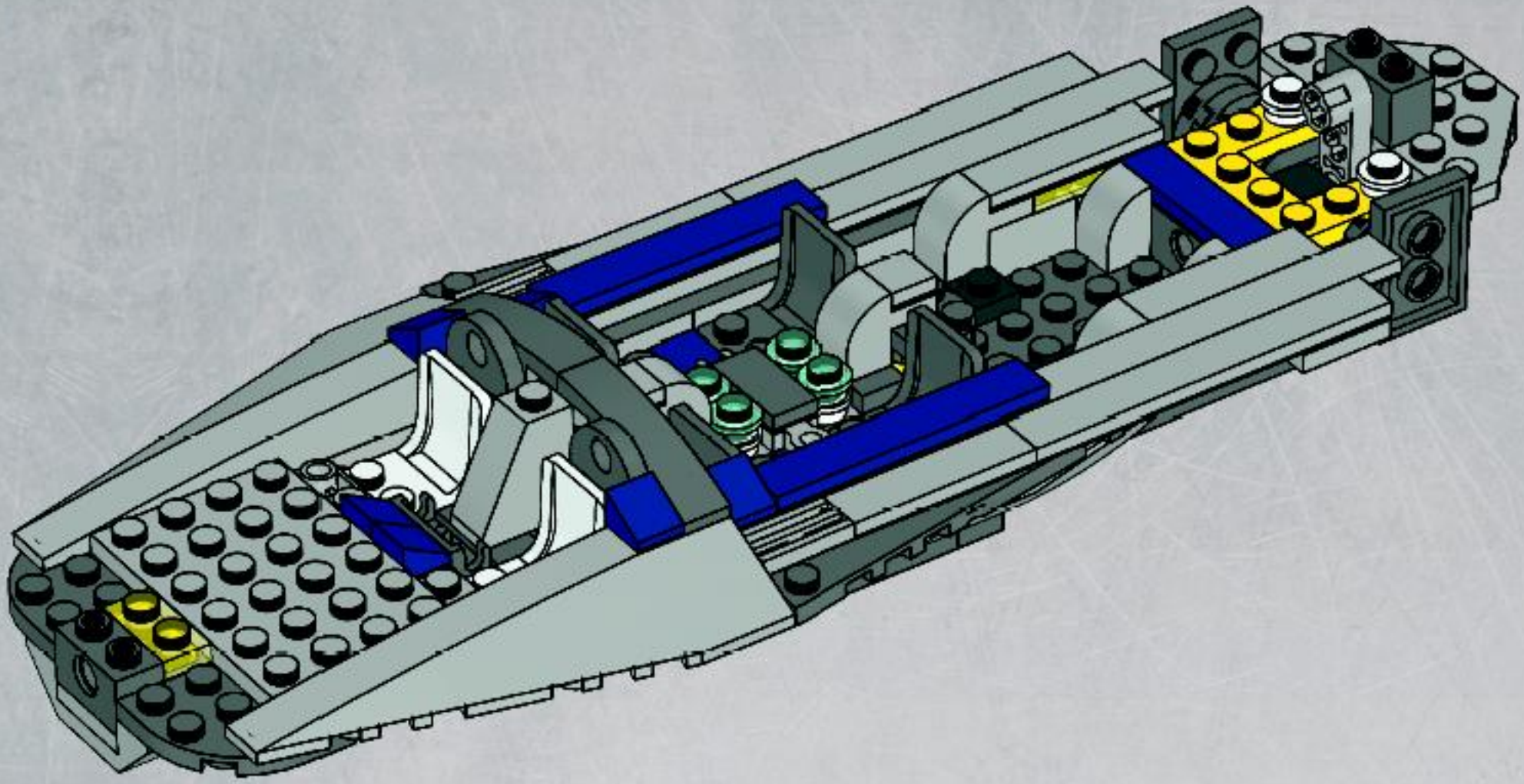

1x



1x



1x



1x

1



2



3



35

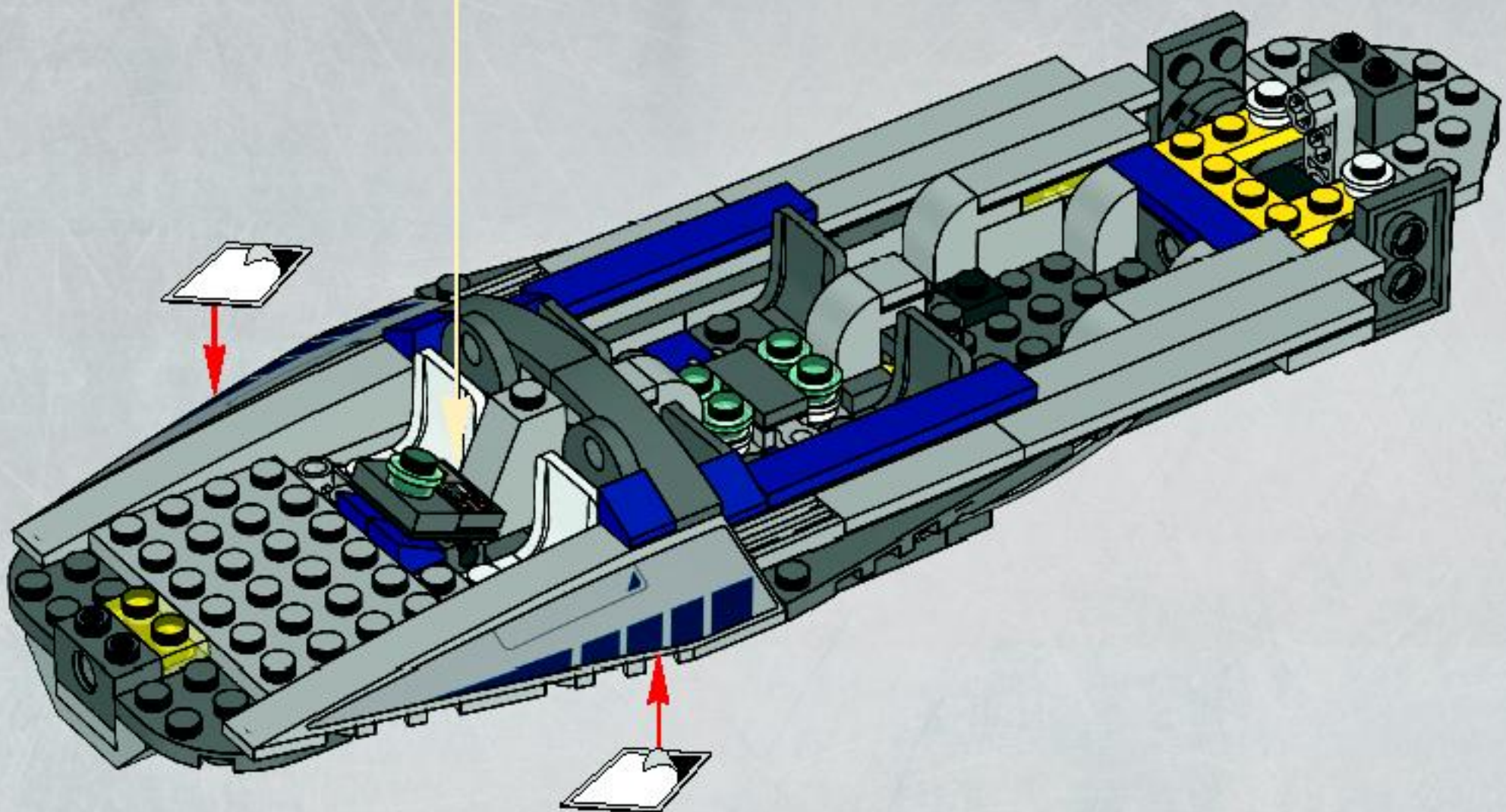

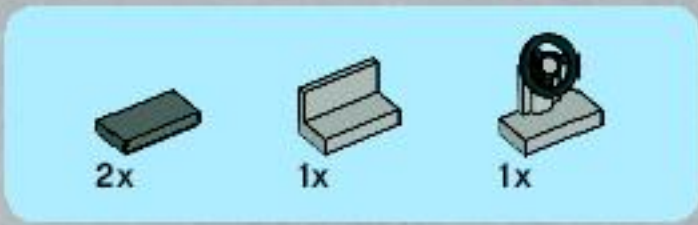

36

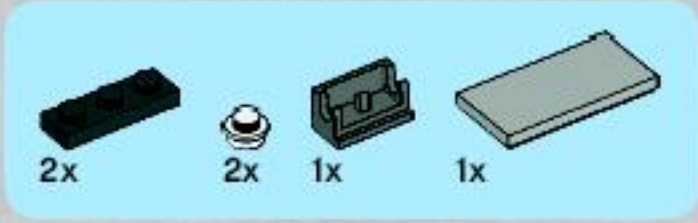
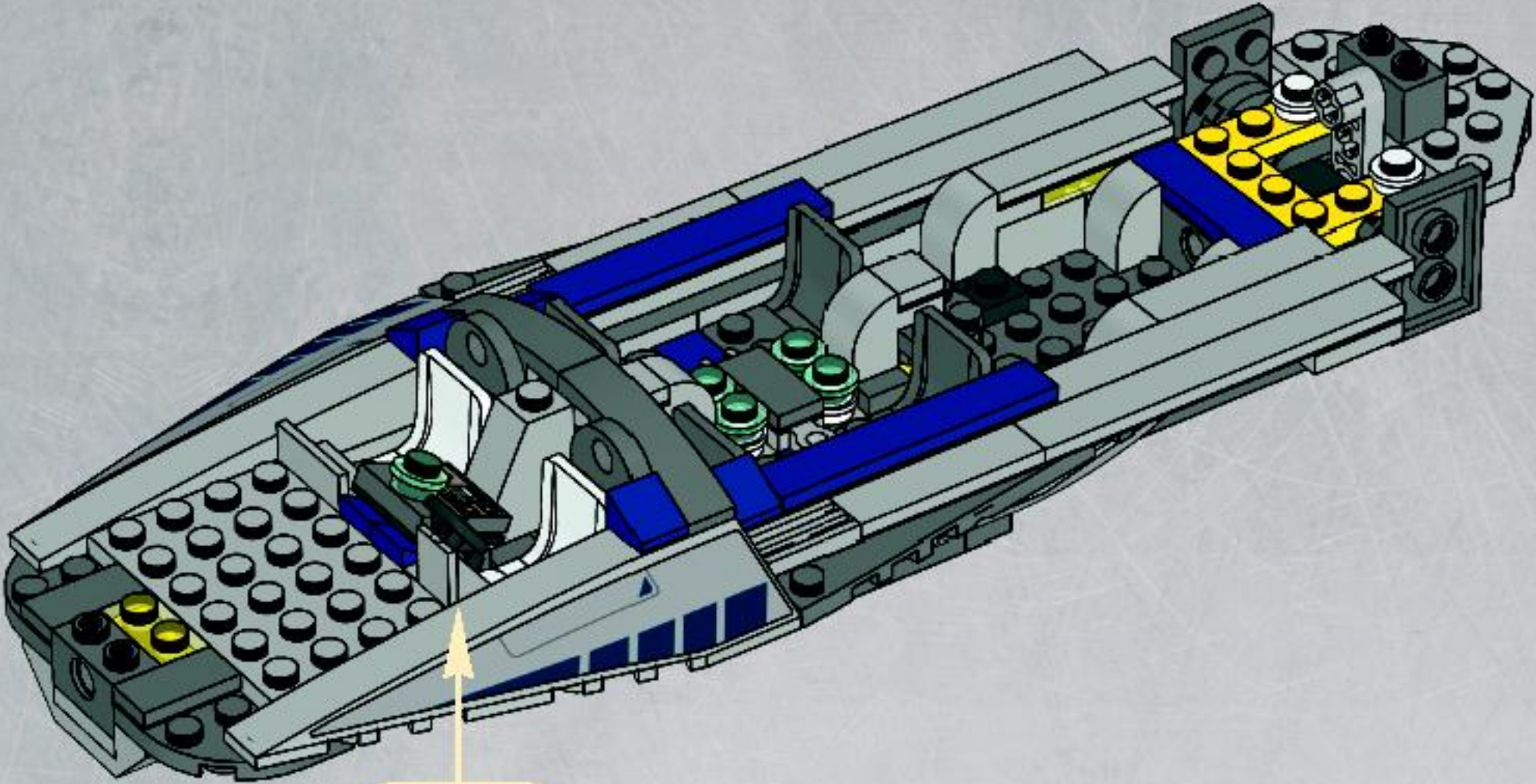

37

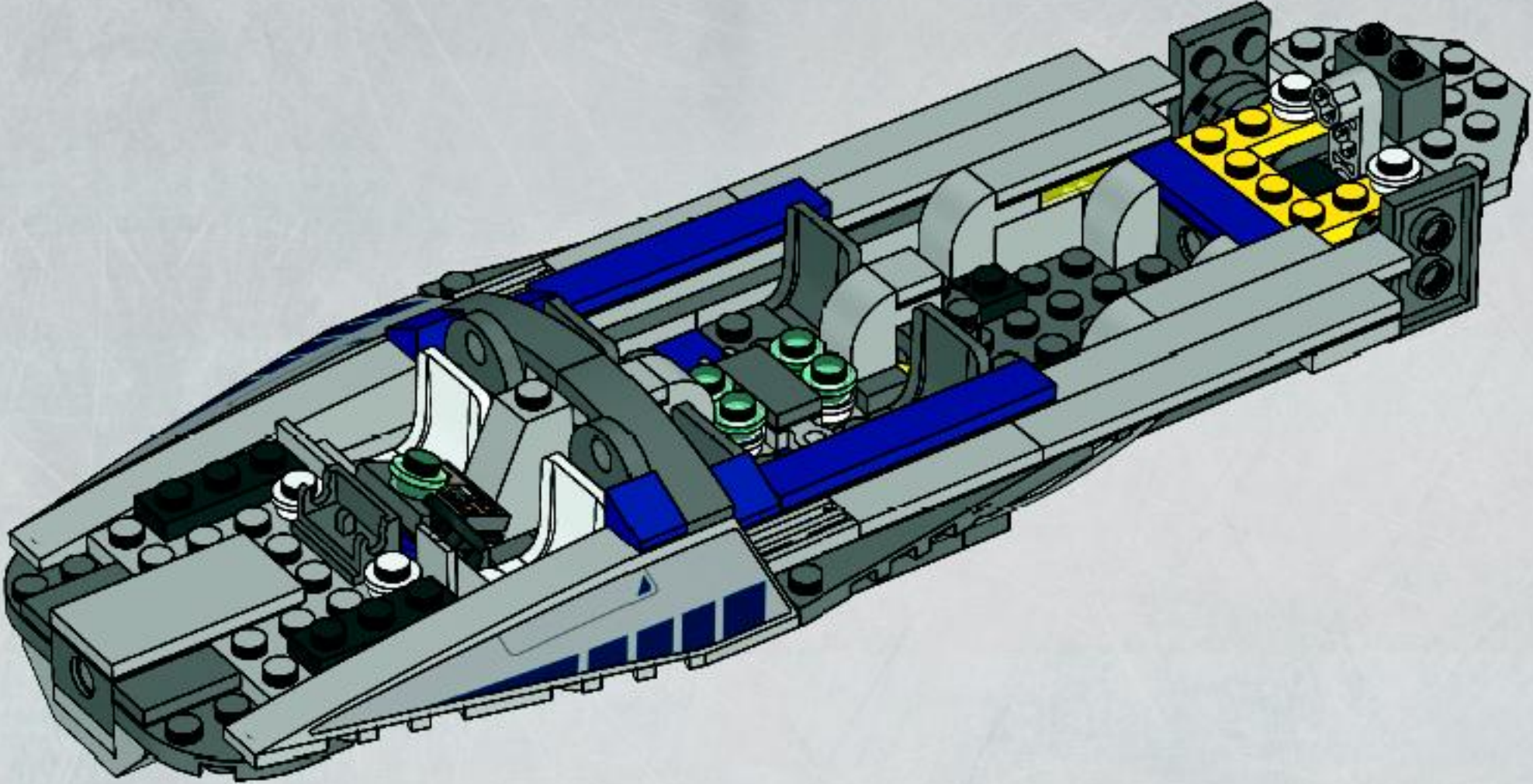



38

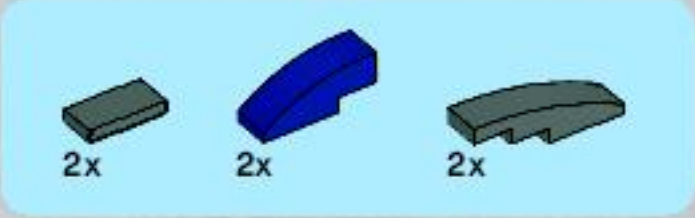
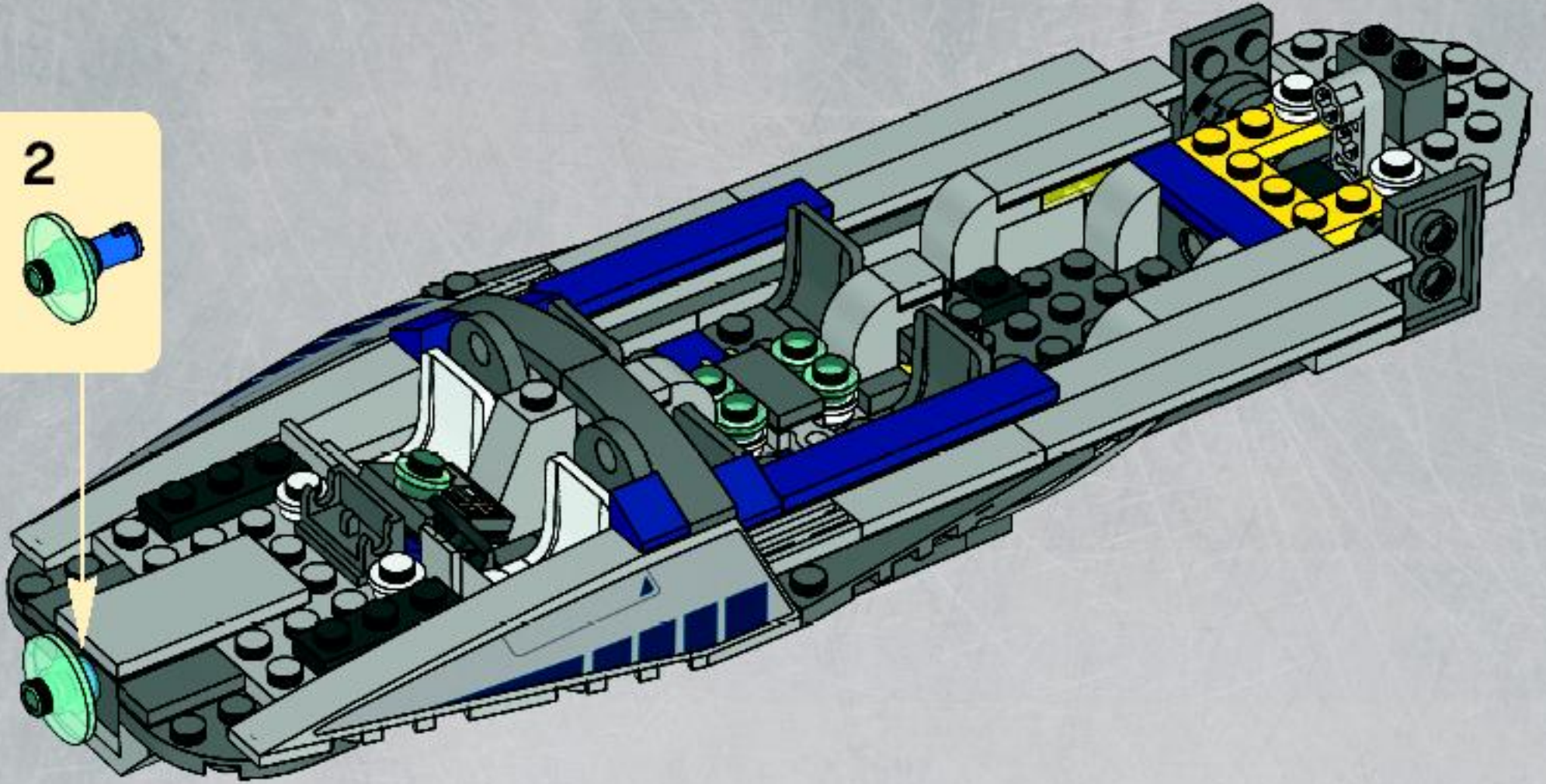
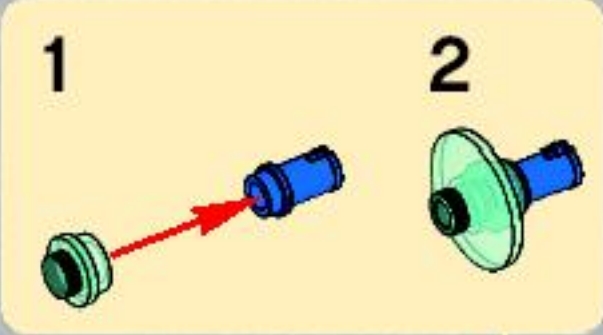

39

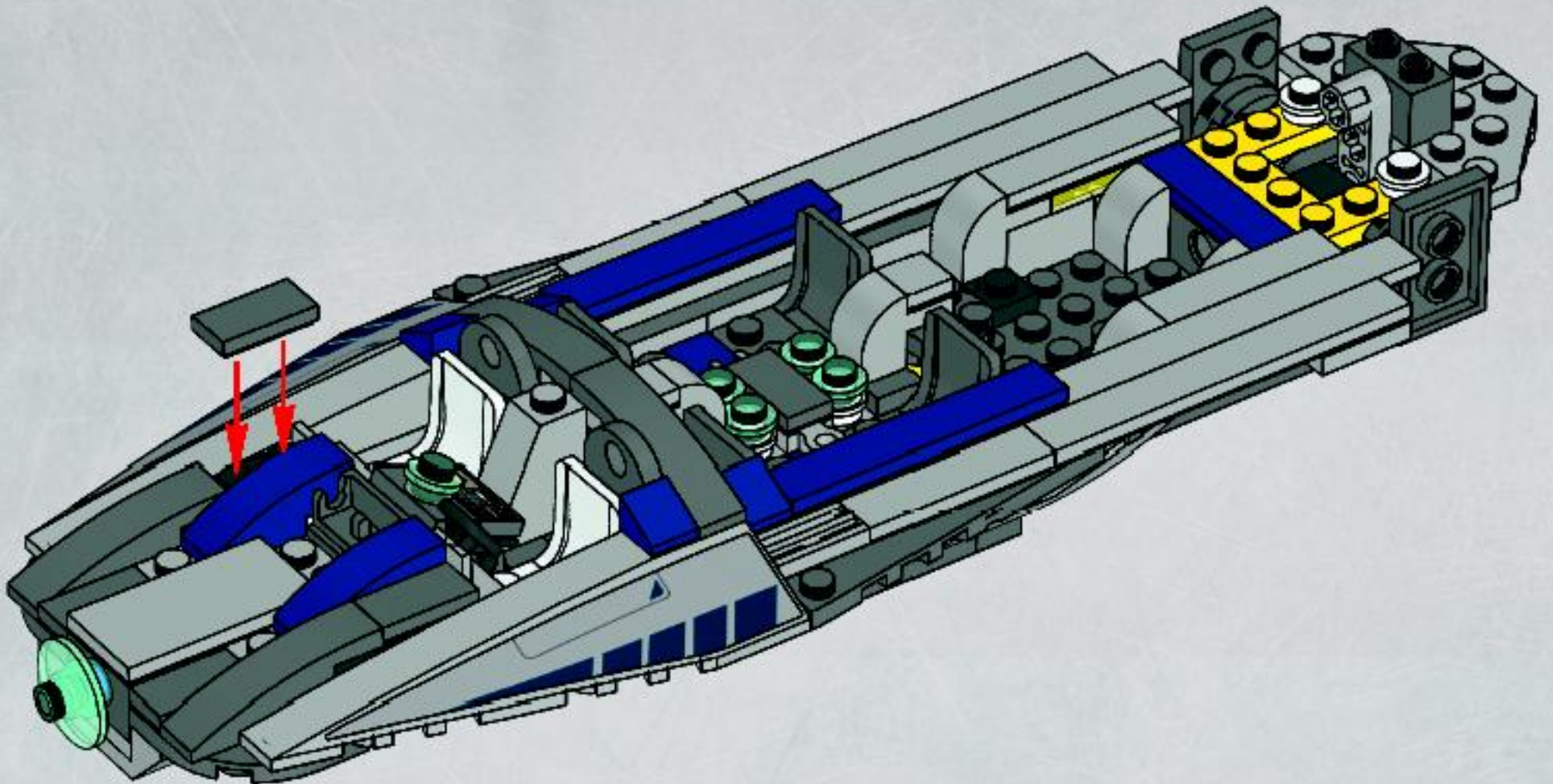

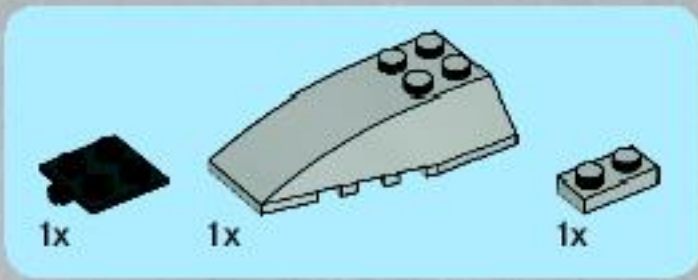

40

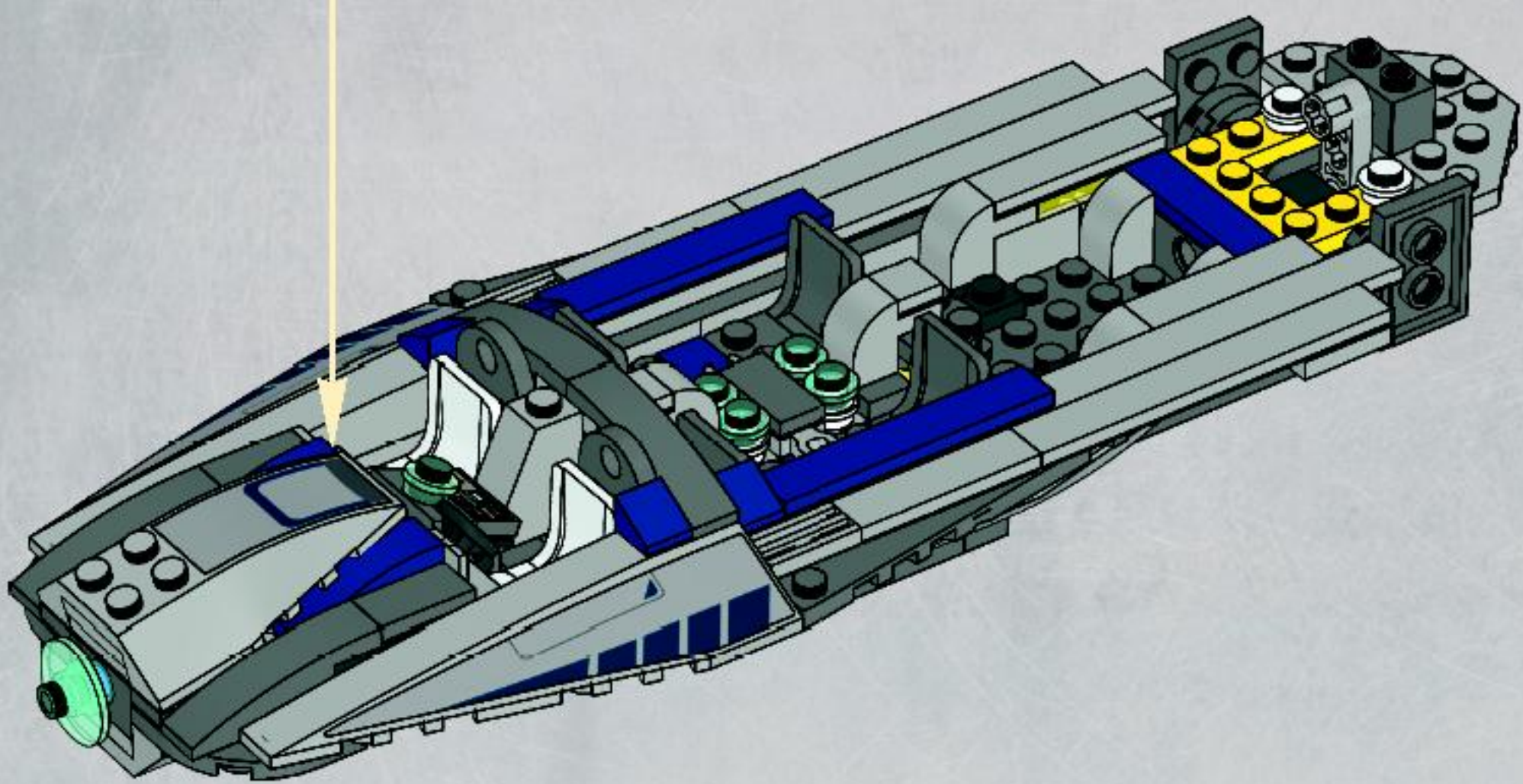
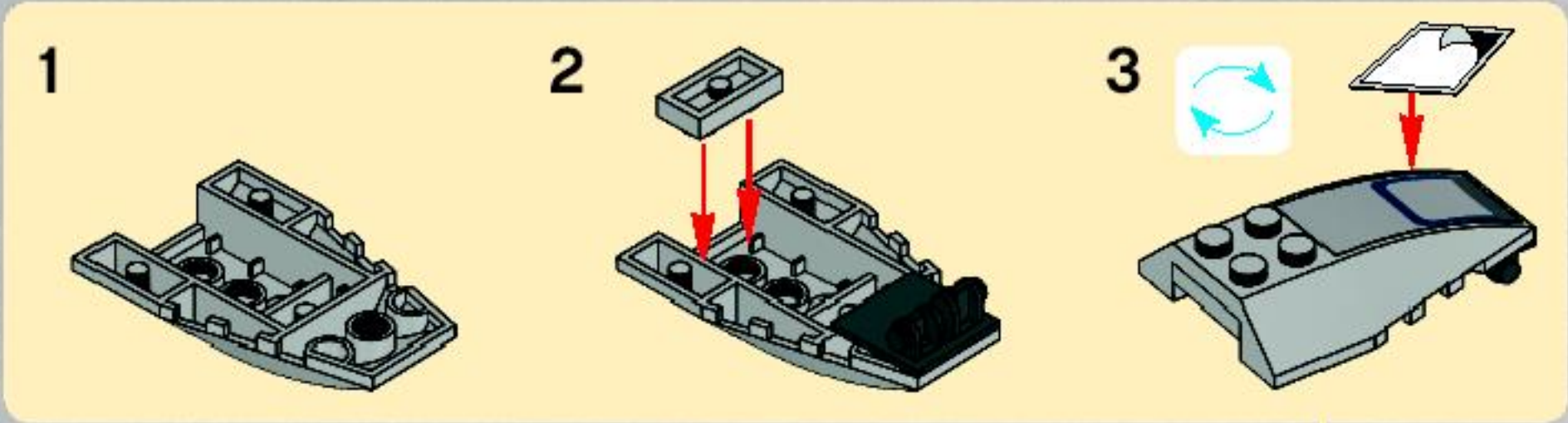

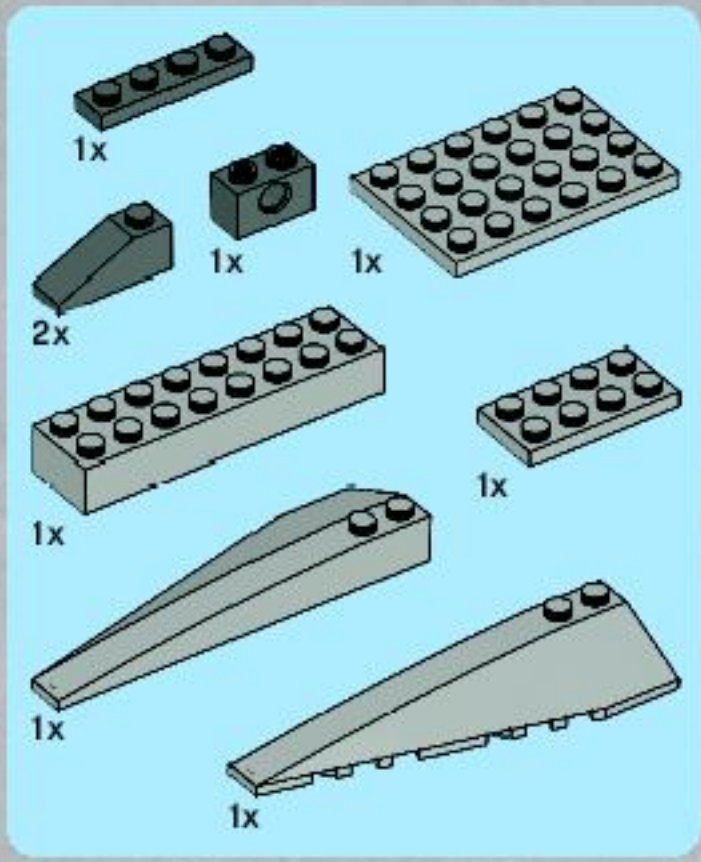

41

1

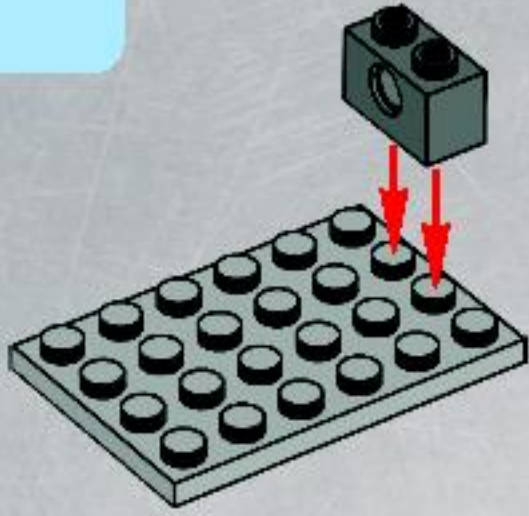

3

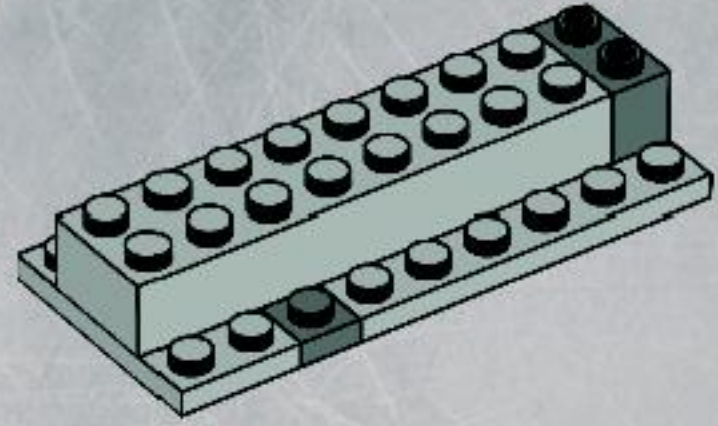

4

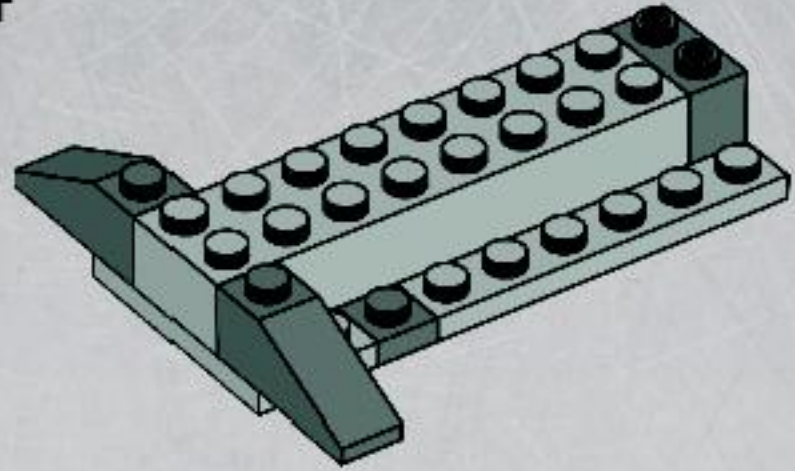

5

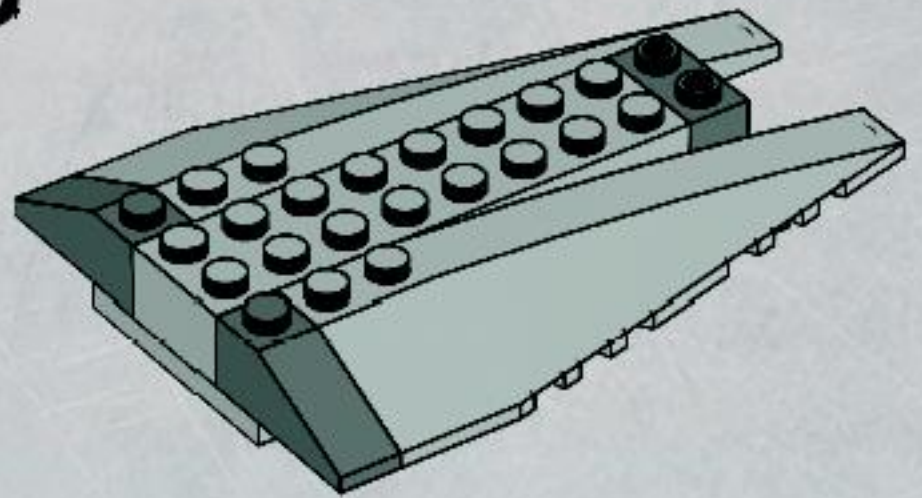

2

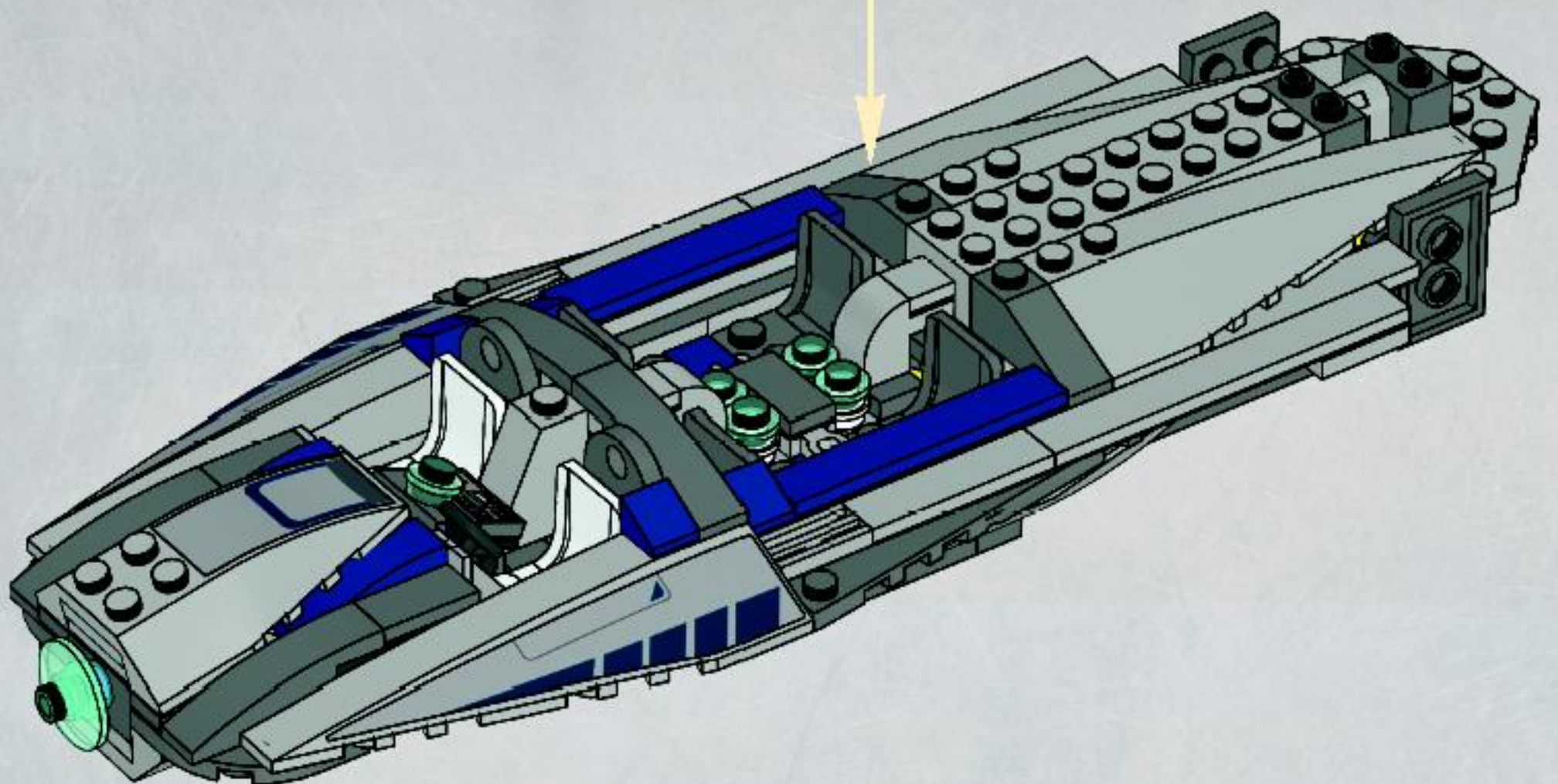
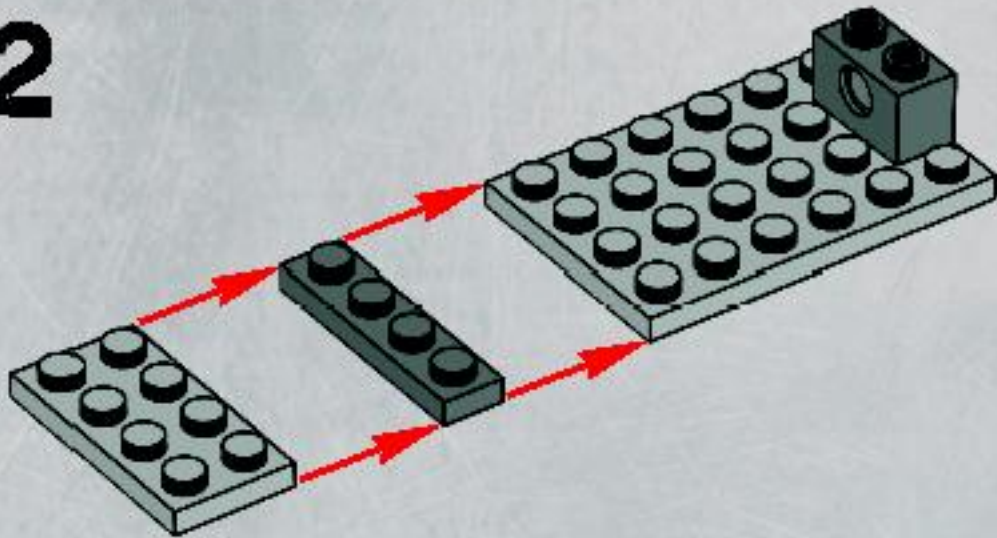

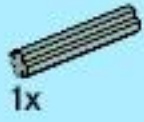

1x

42

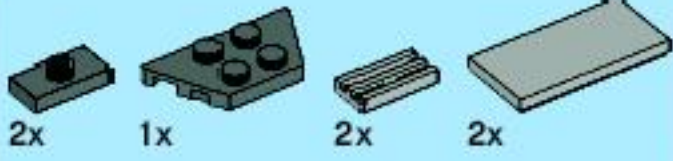
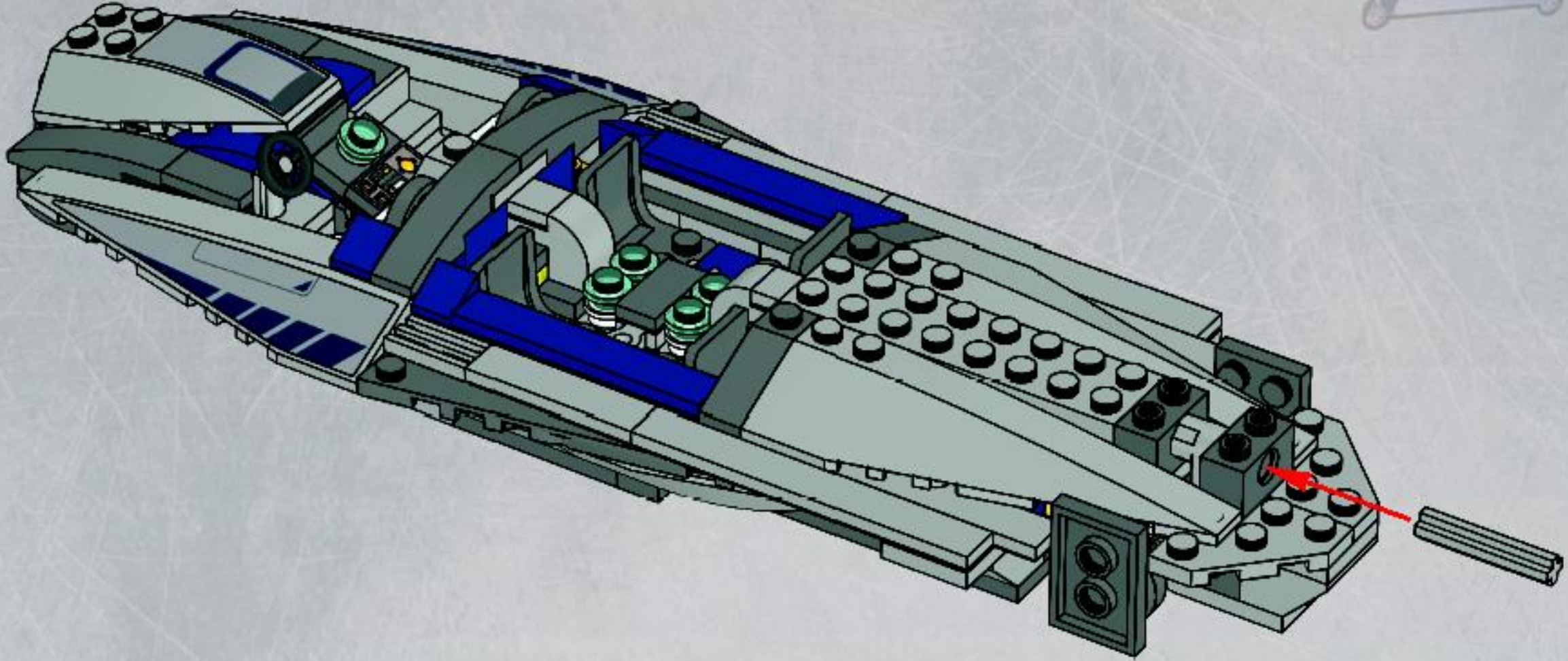

2x

1x

2x

2x

43

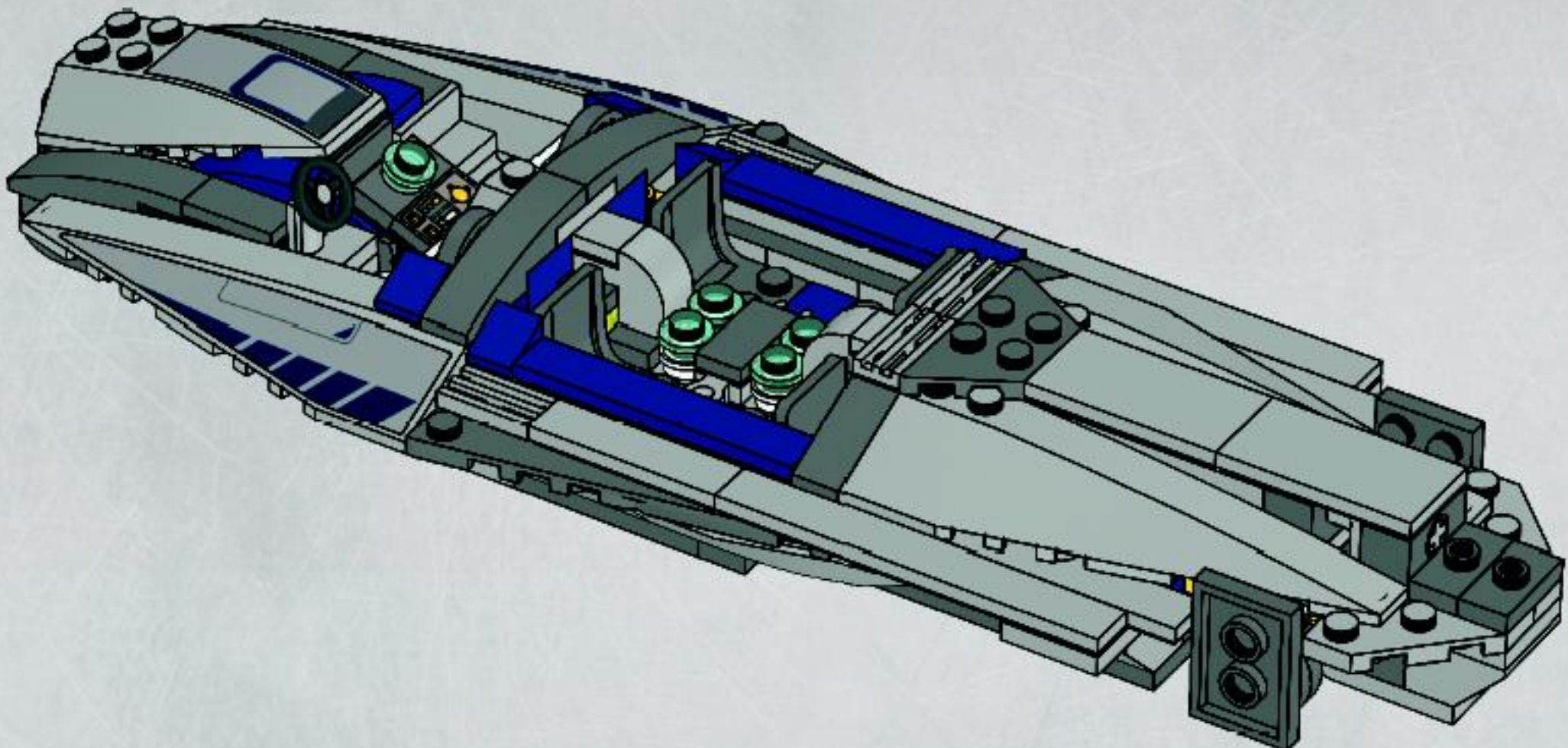

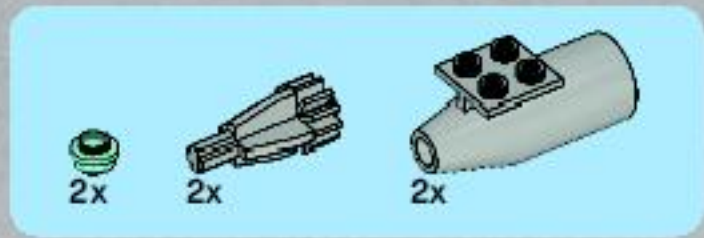

44

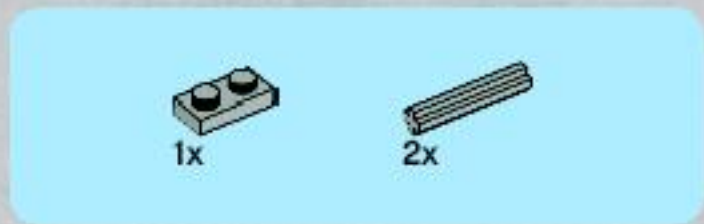
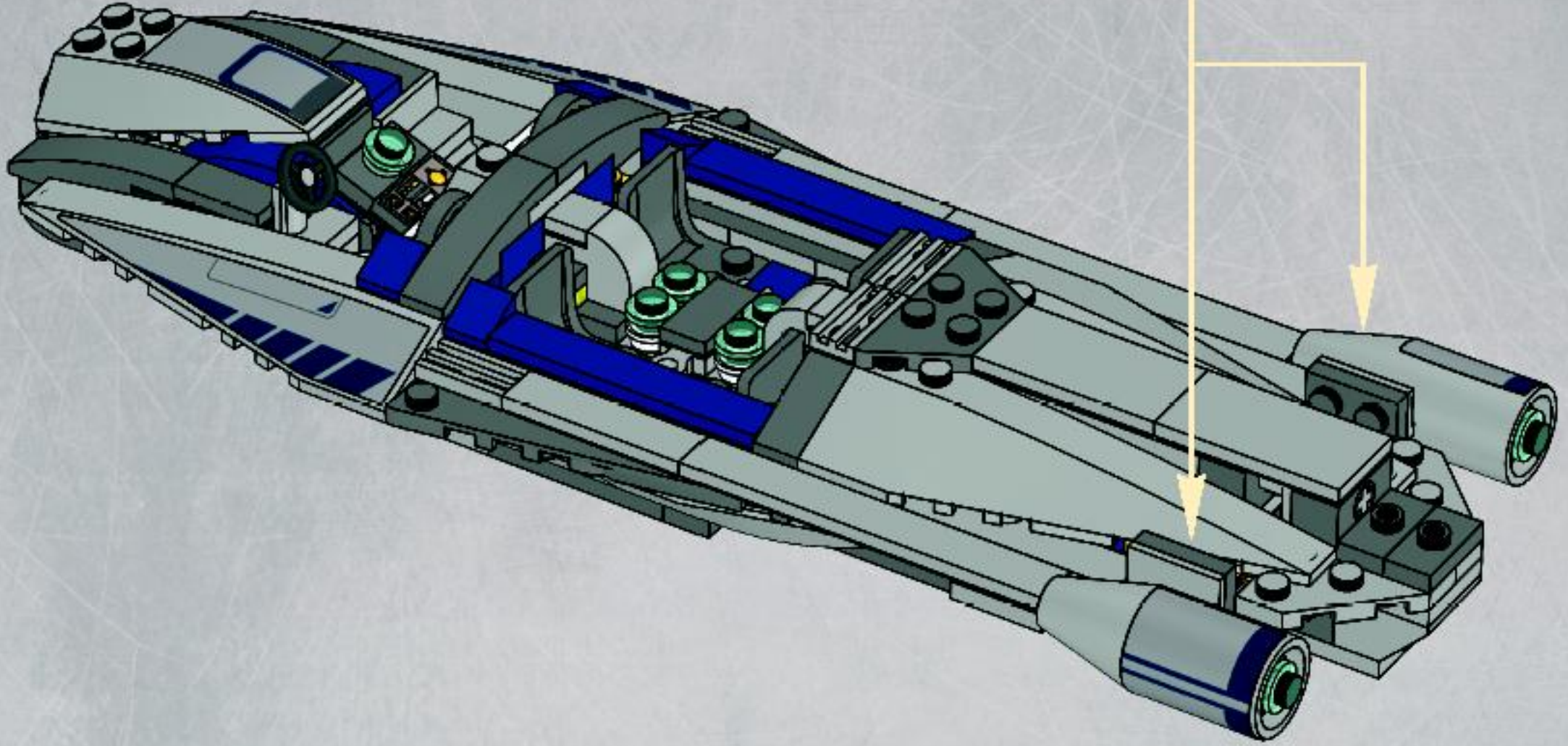
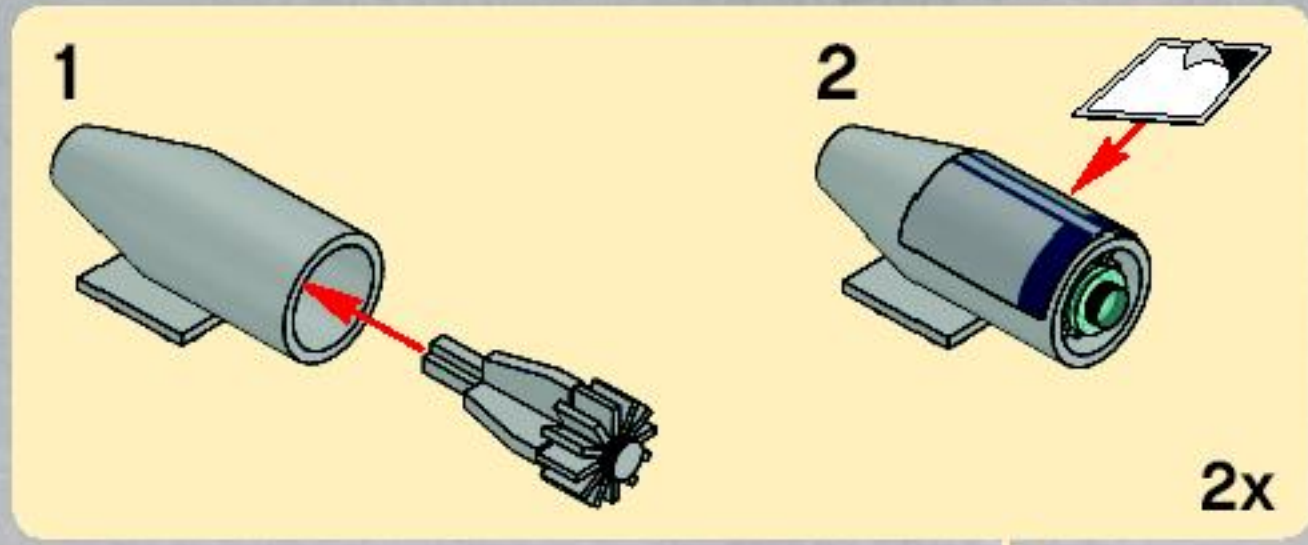

45

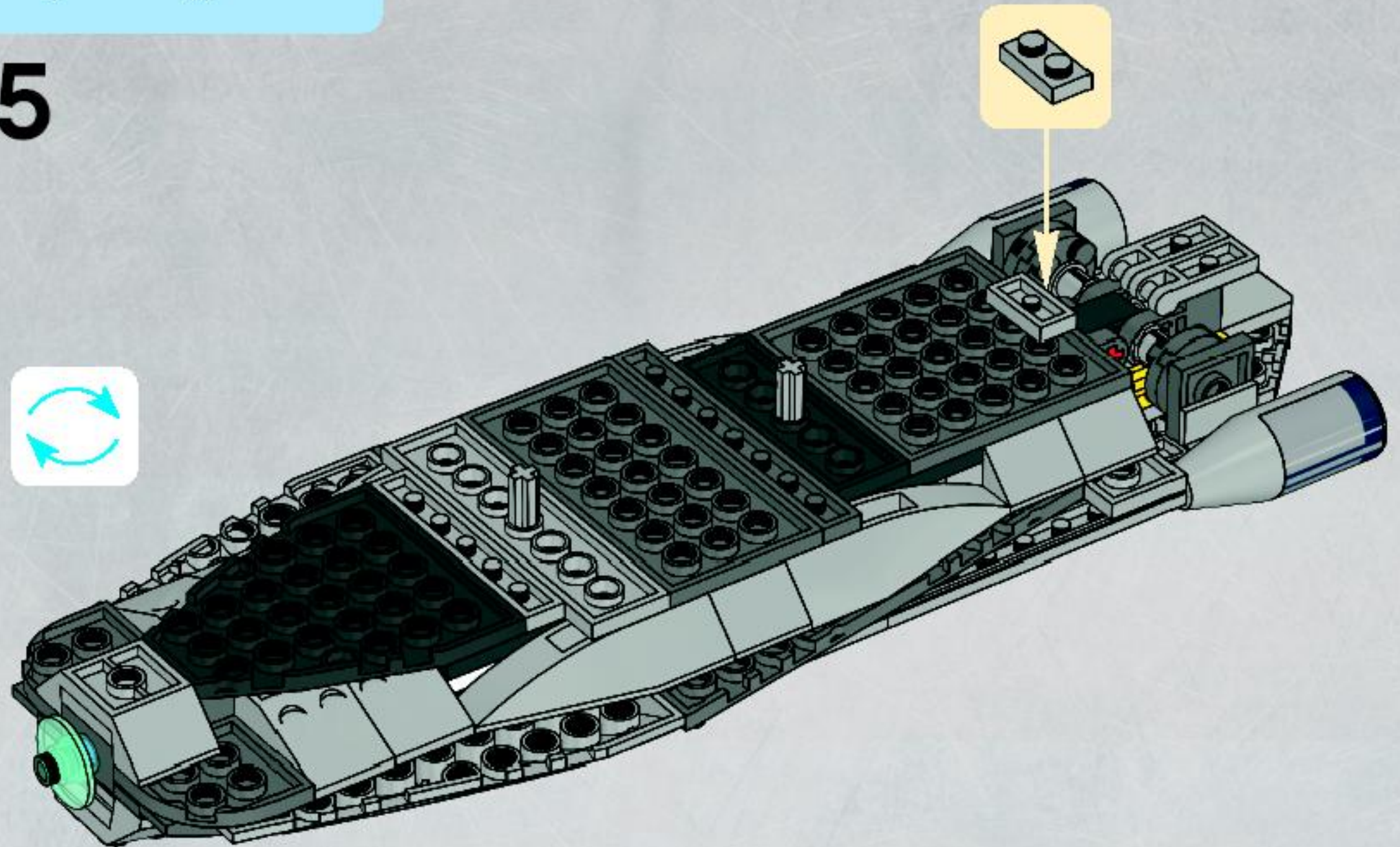



2x



2x

46

1

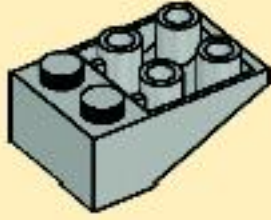

2

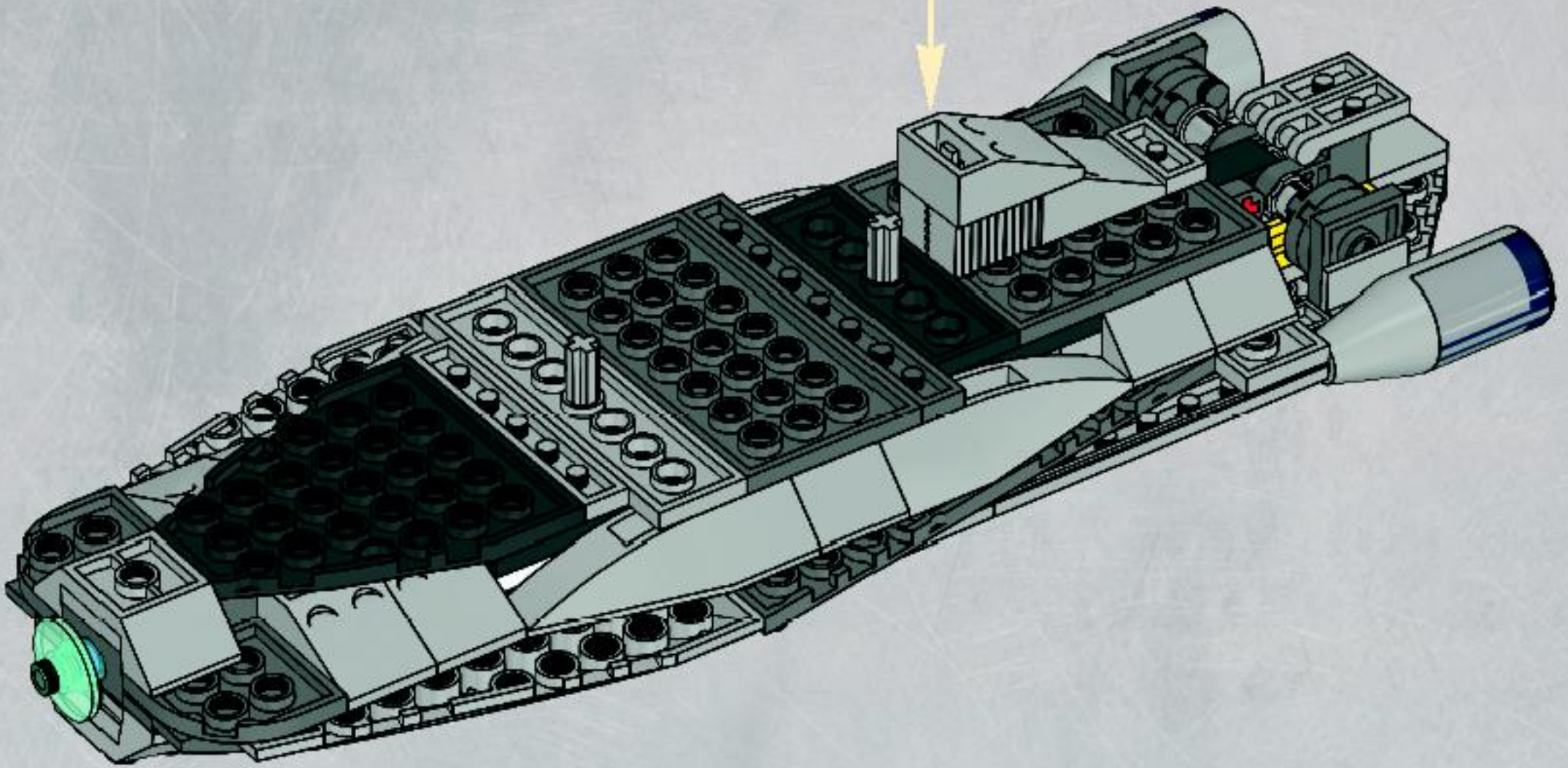
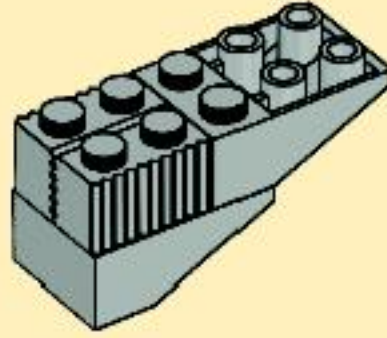

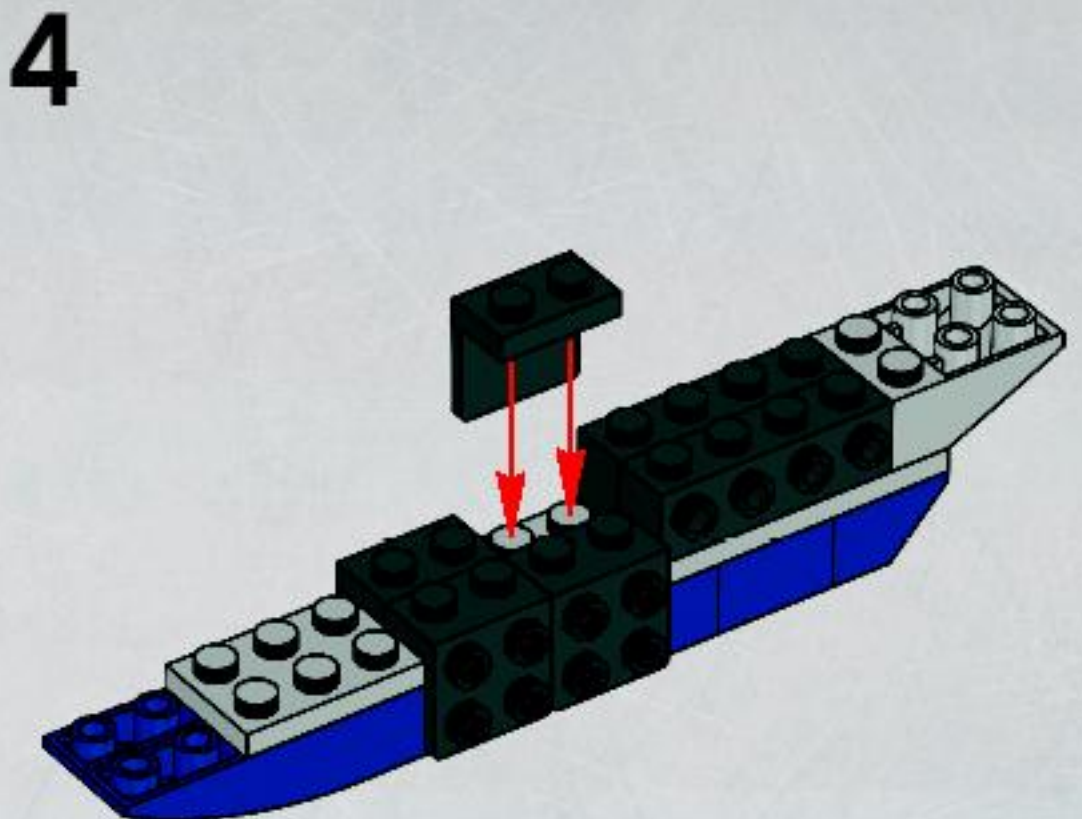
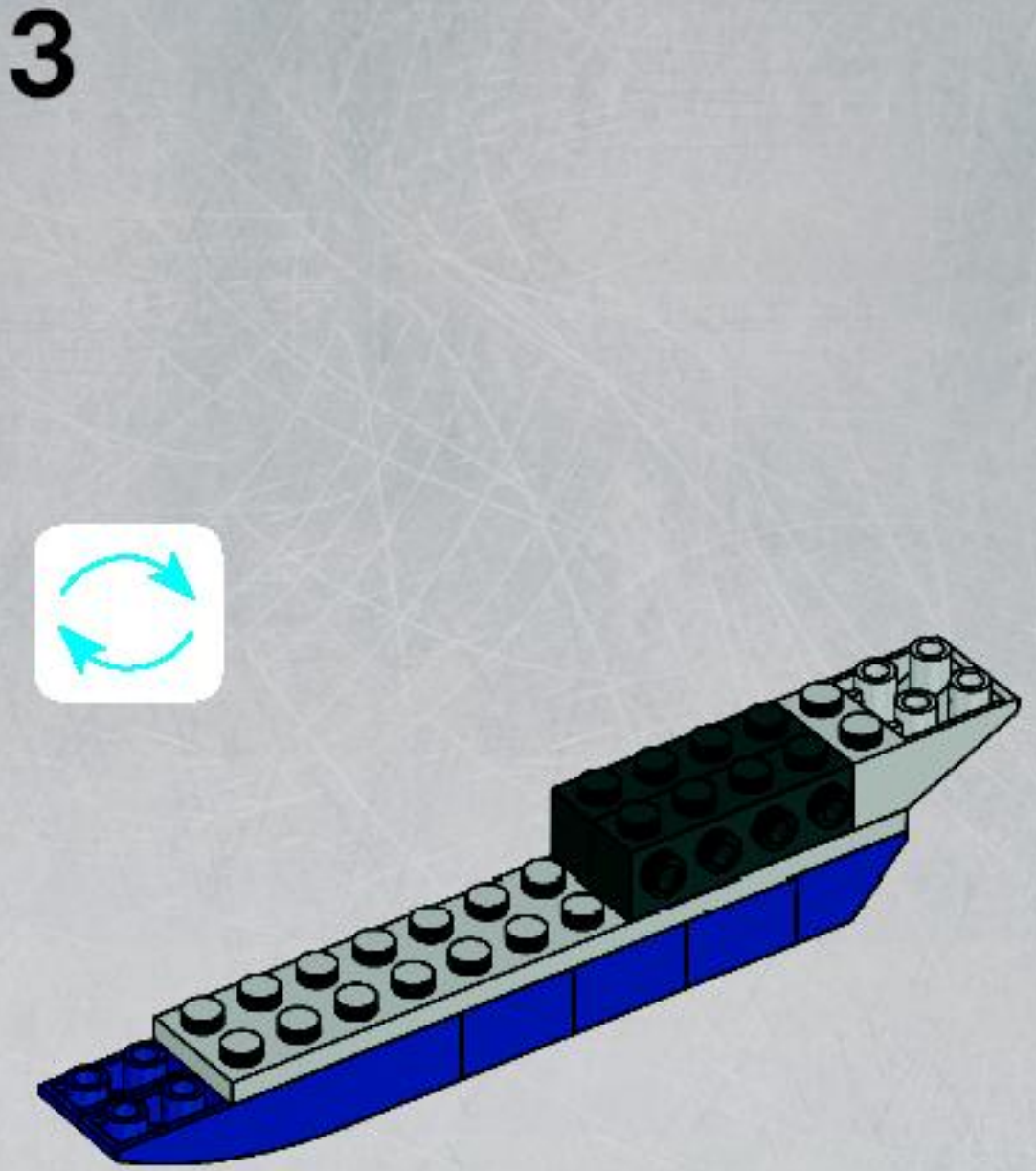
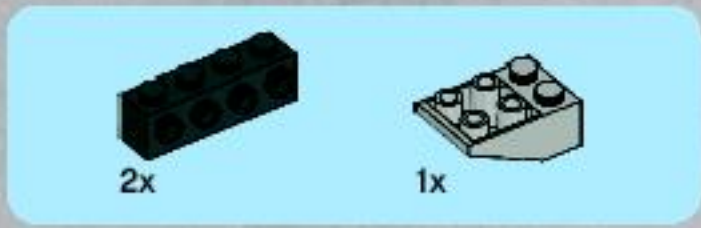
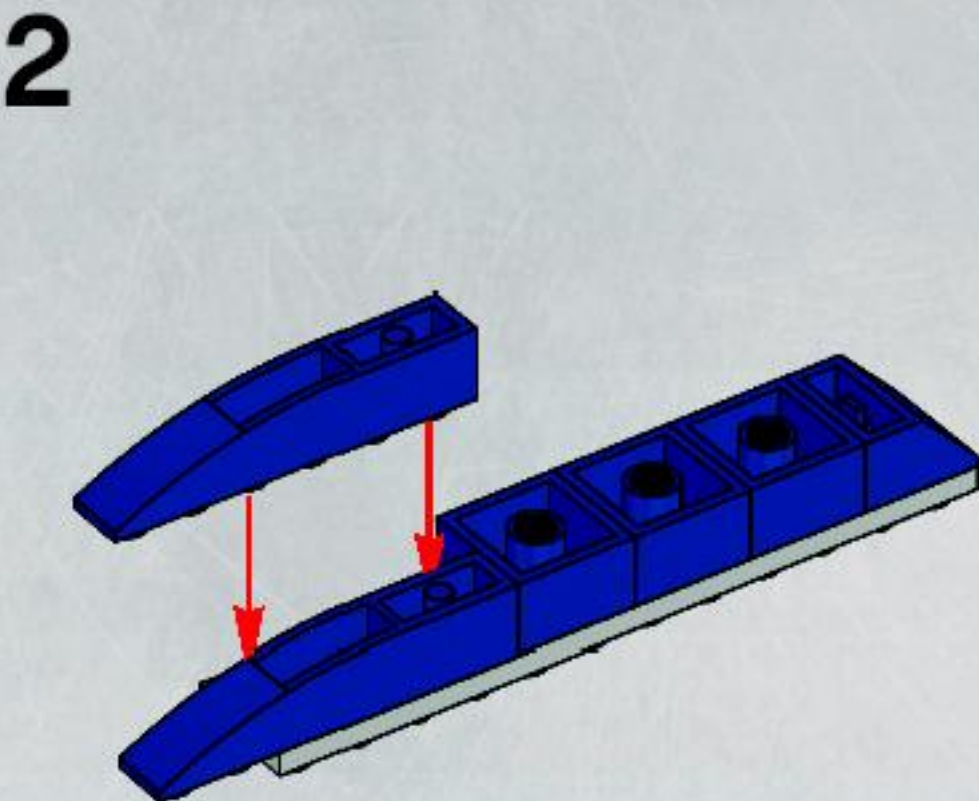
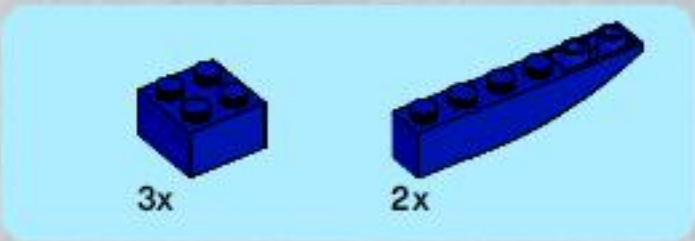
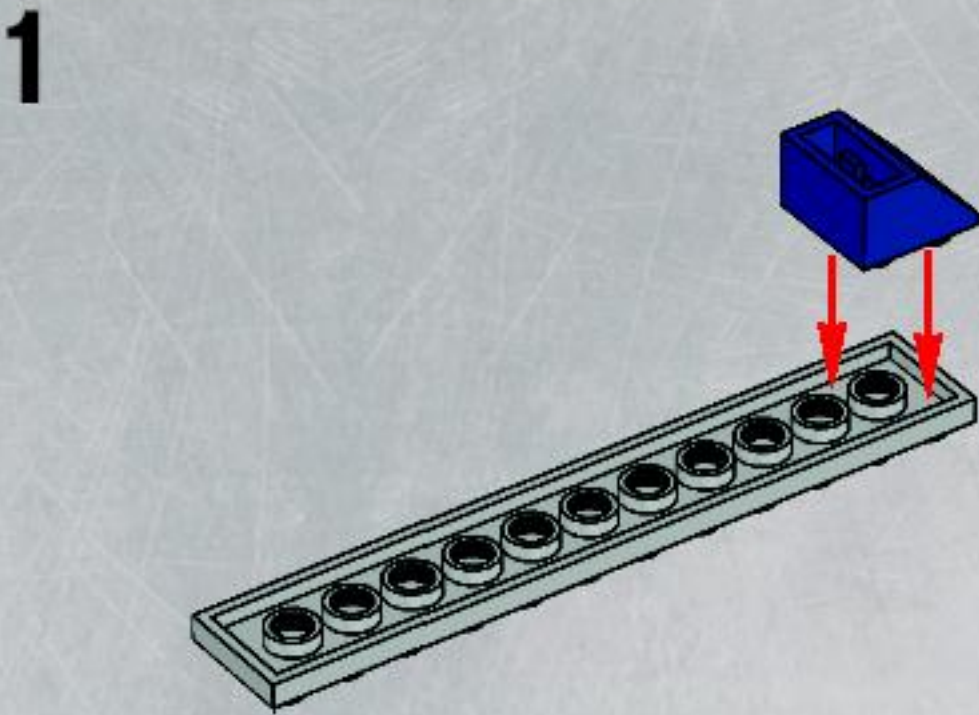
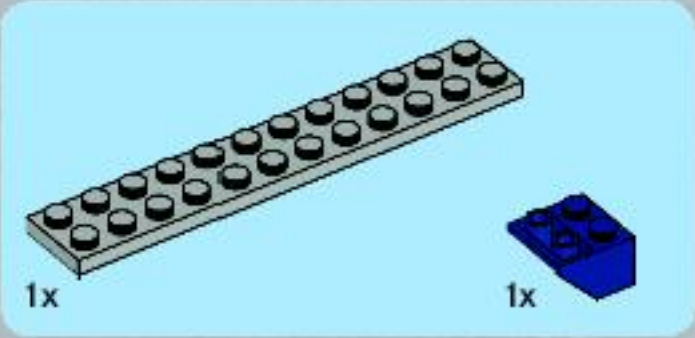
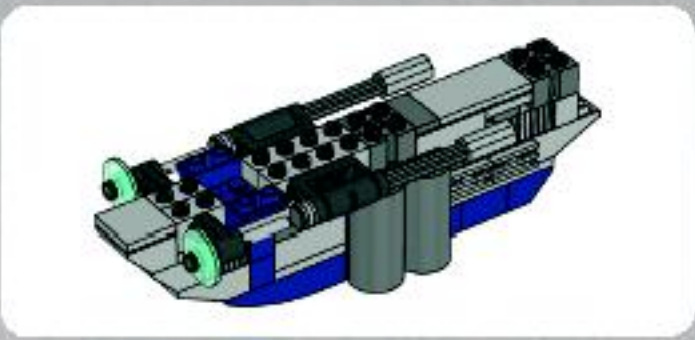

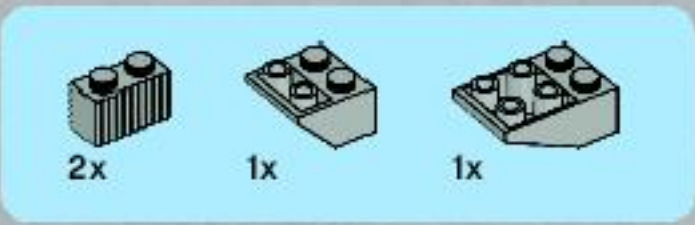

9

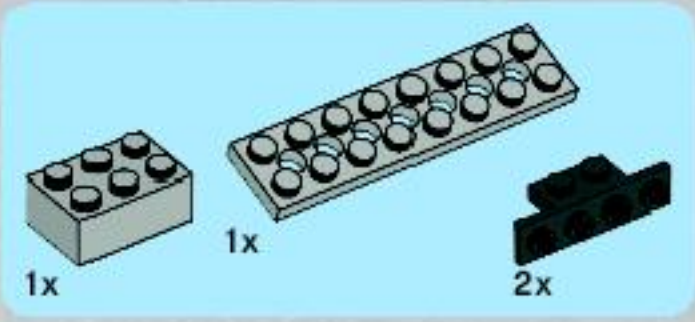
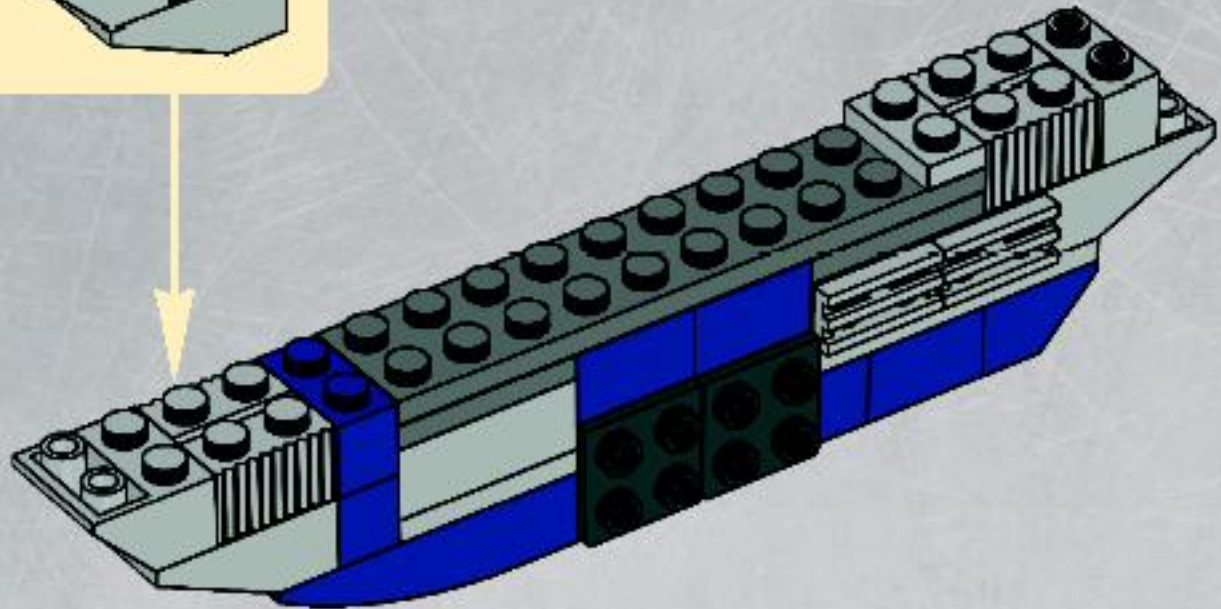
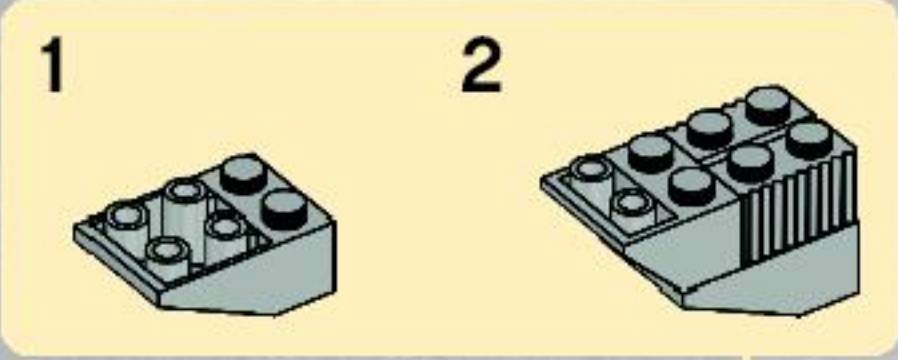

10

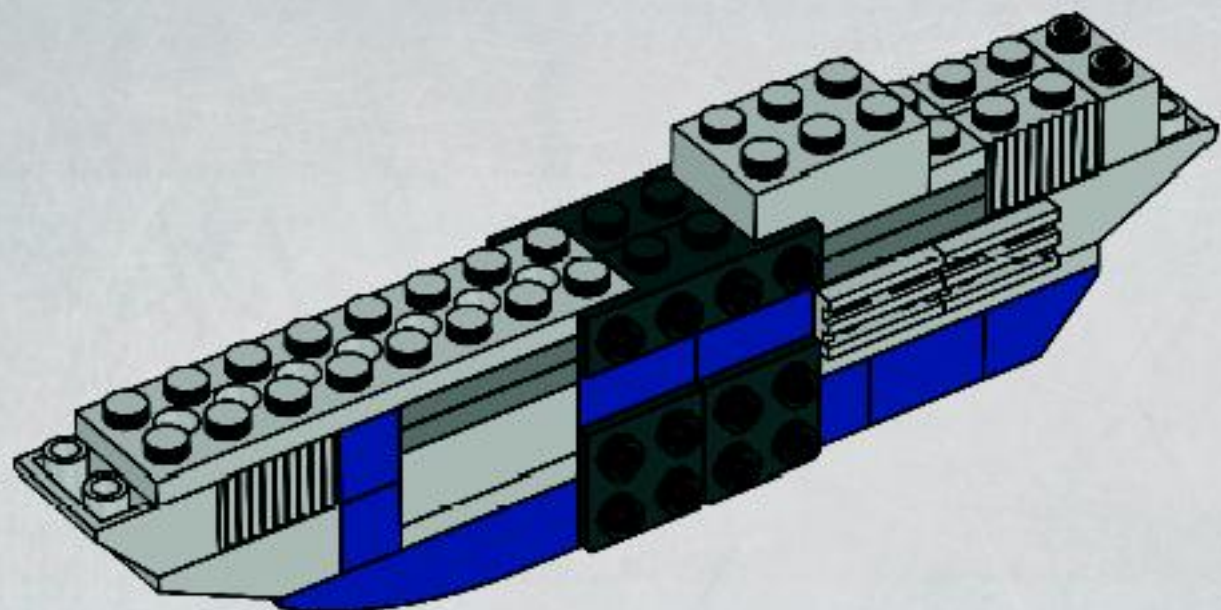



1x



4x

11

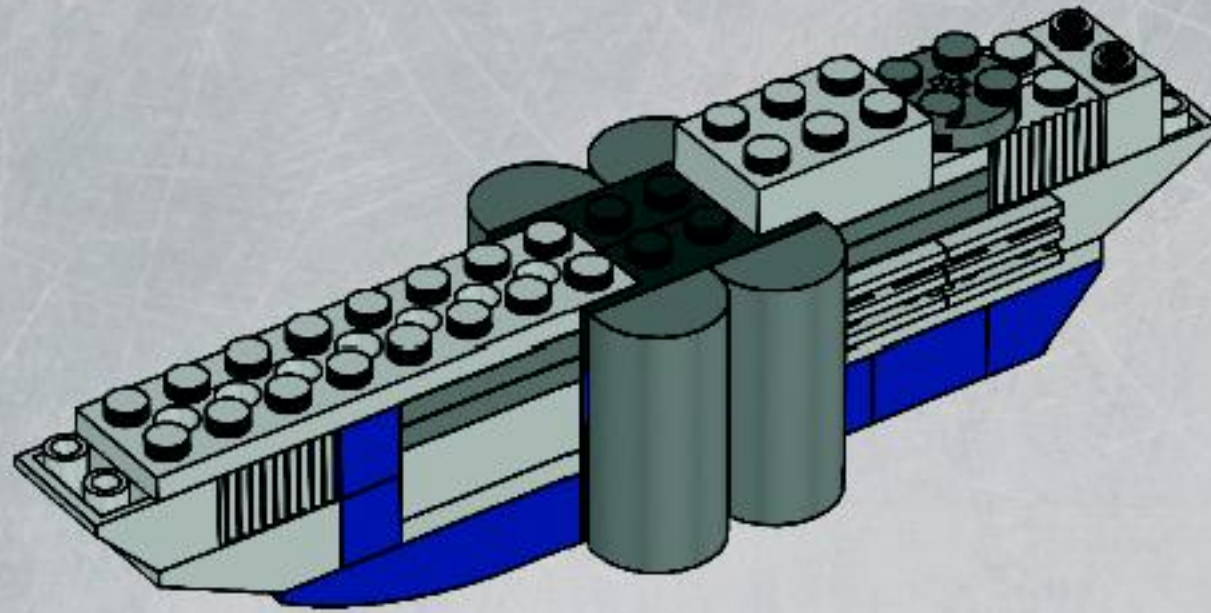

1x



2x

12

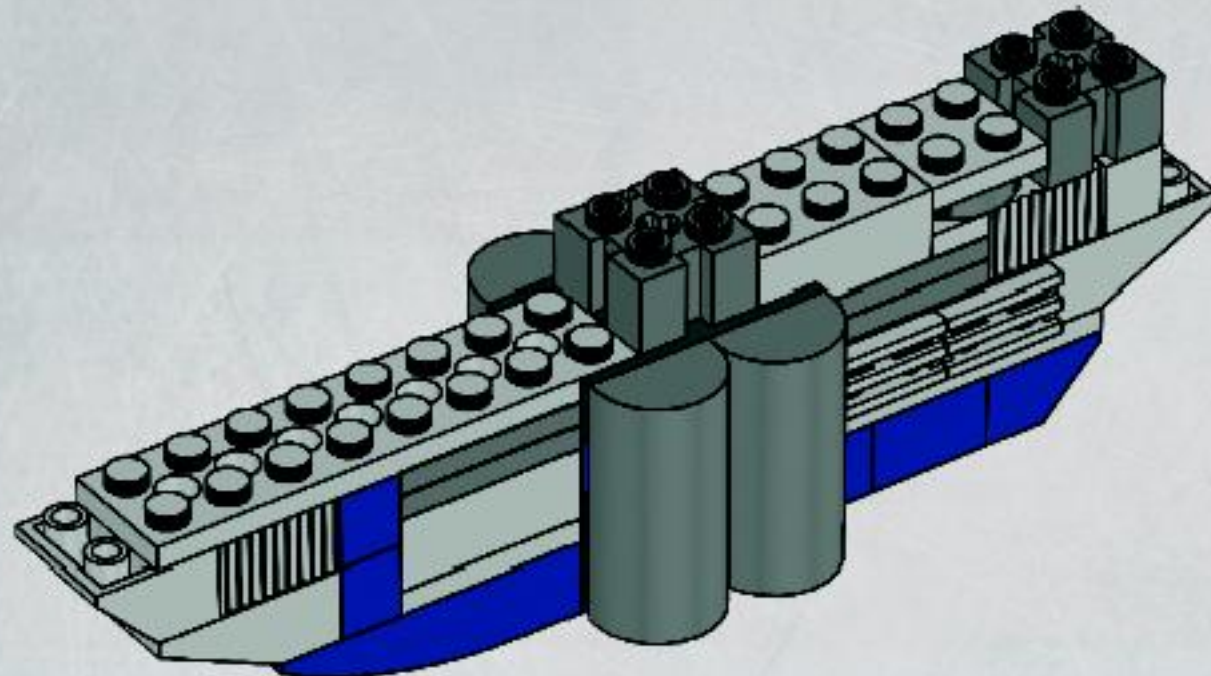

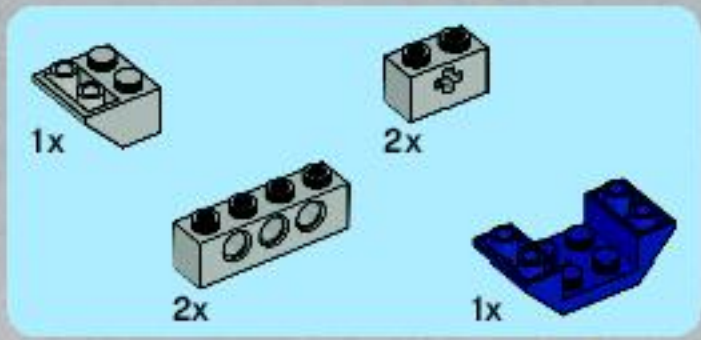

13

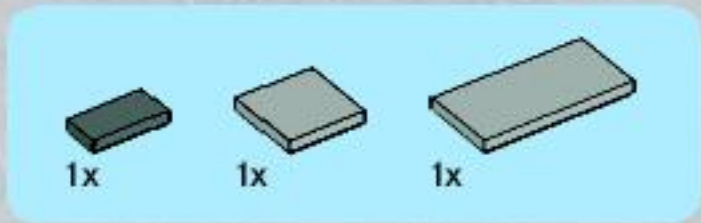
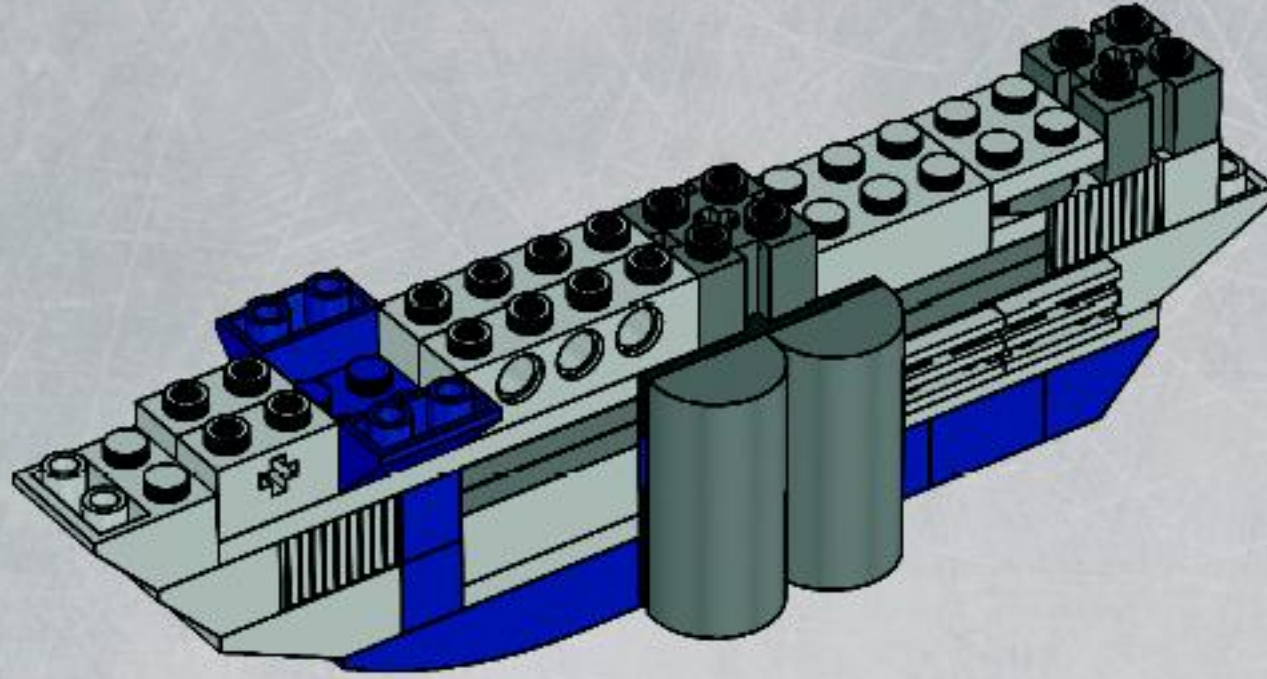

14

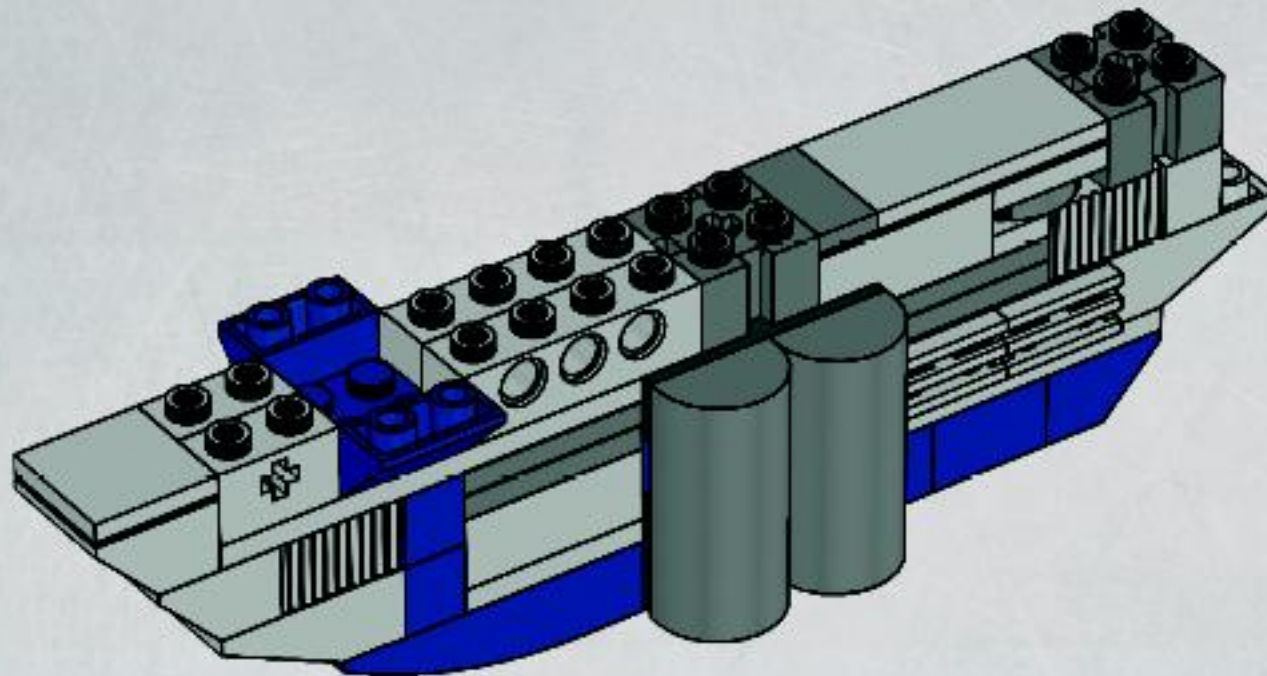

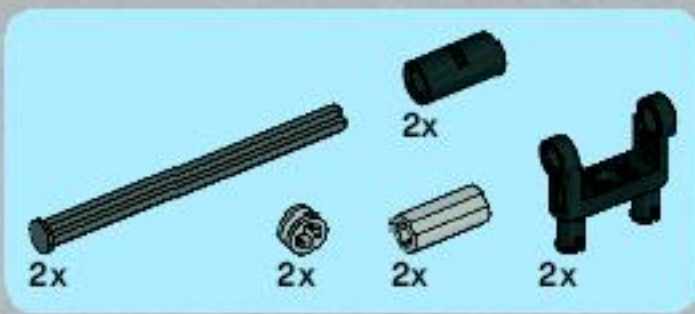

15

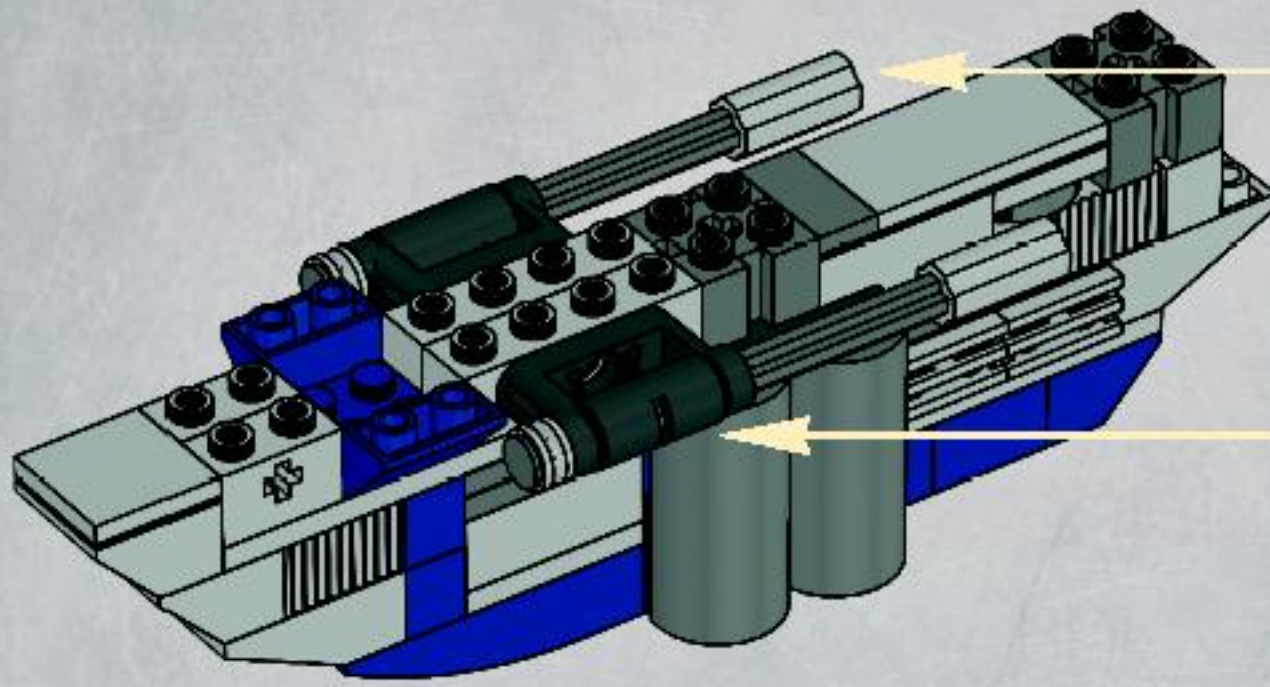
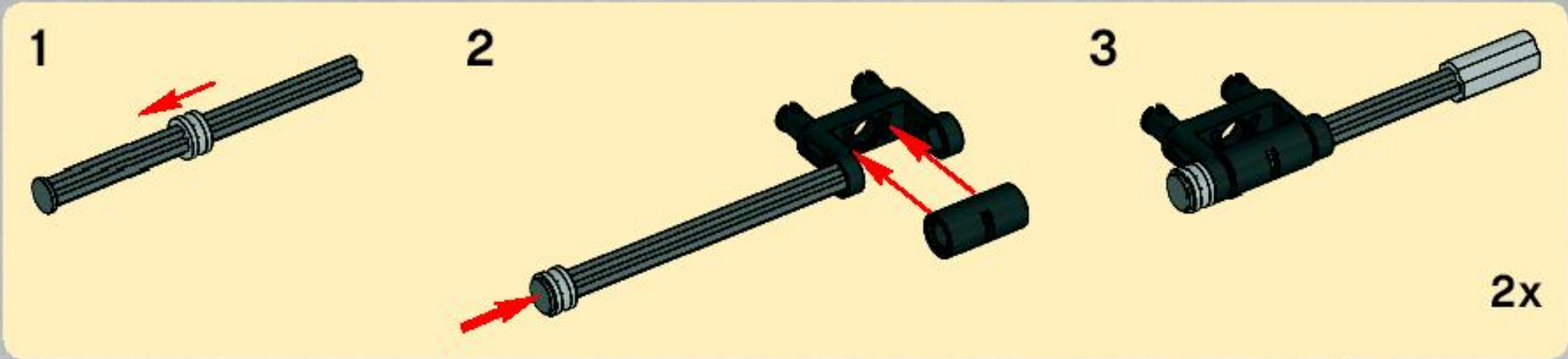

16

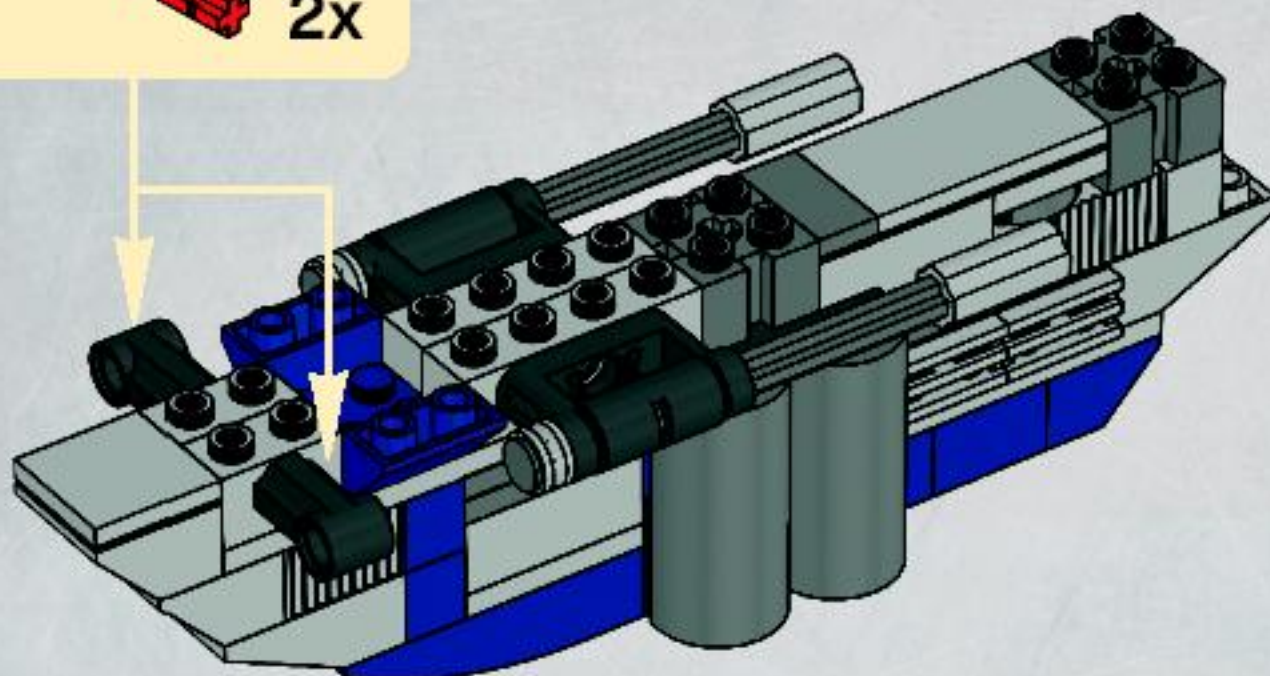
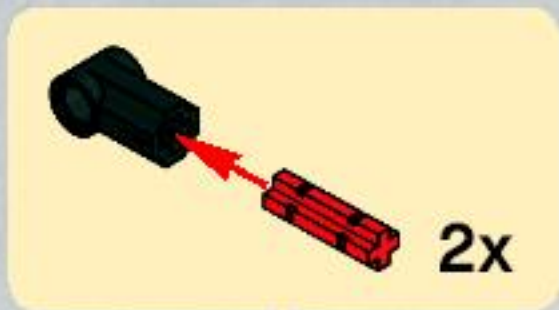



17

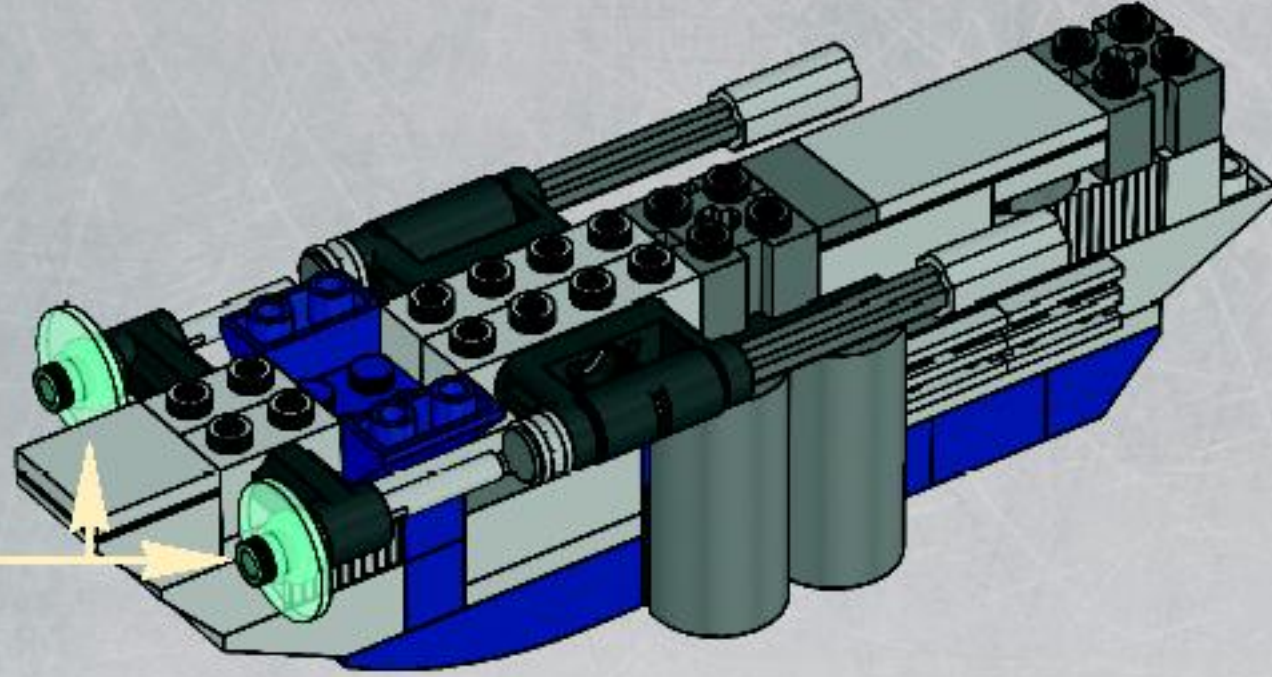
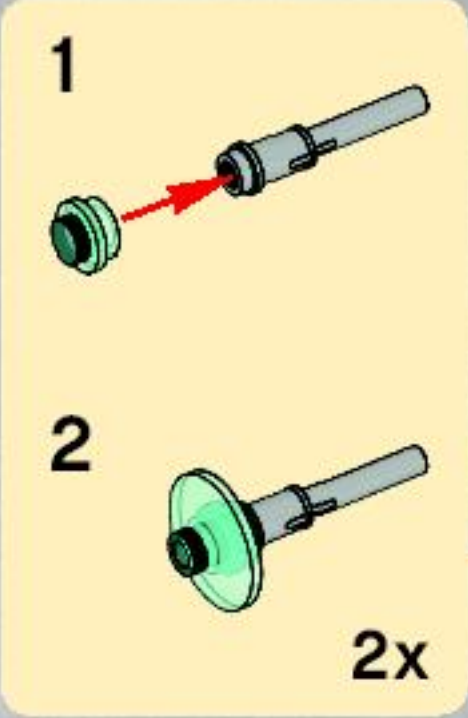

47

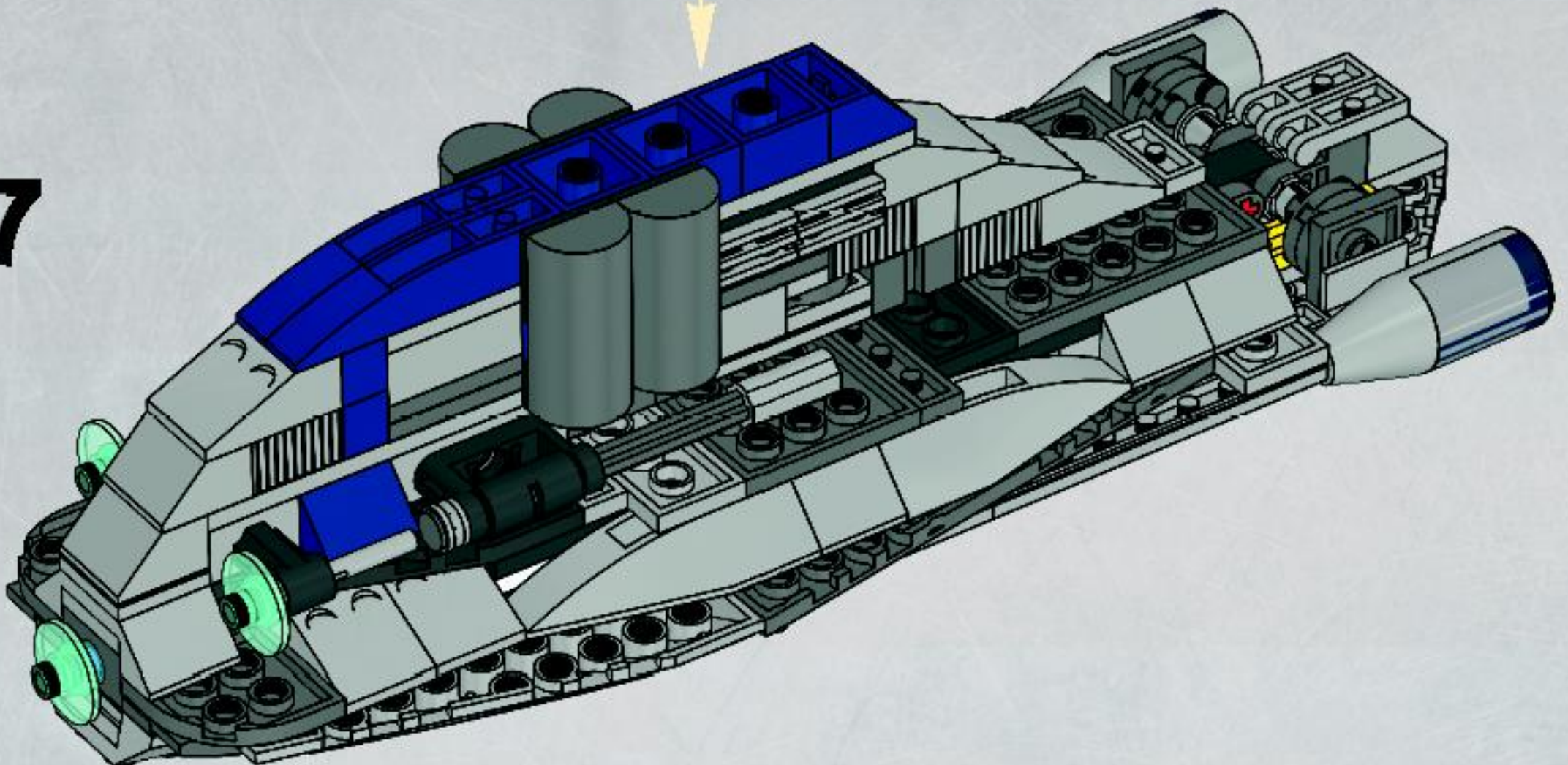

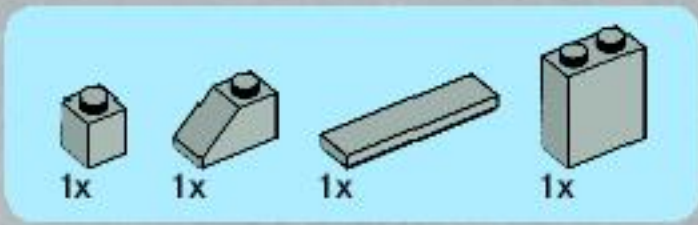

48

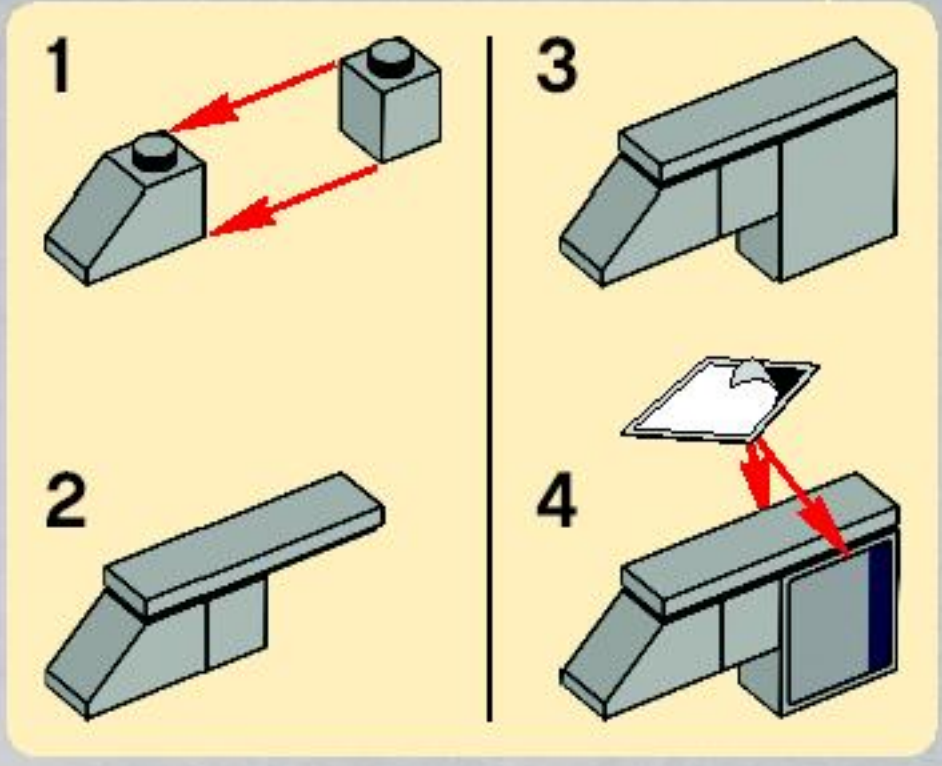
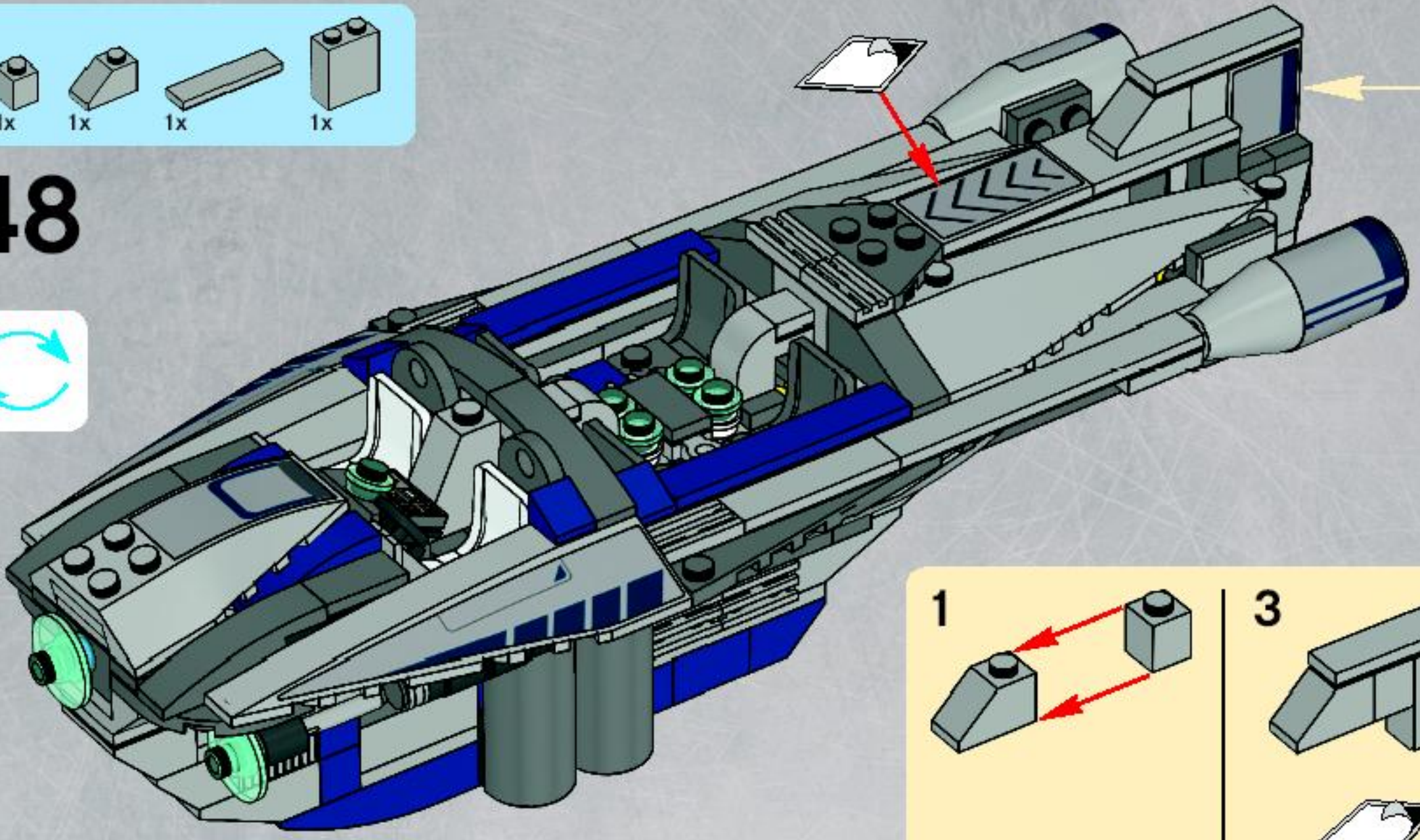

49

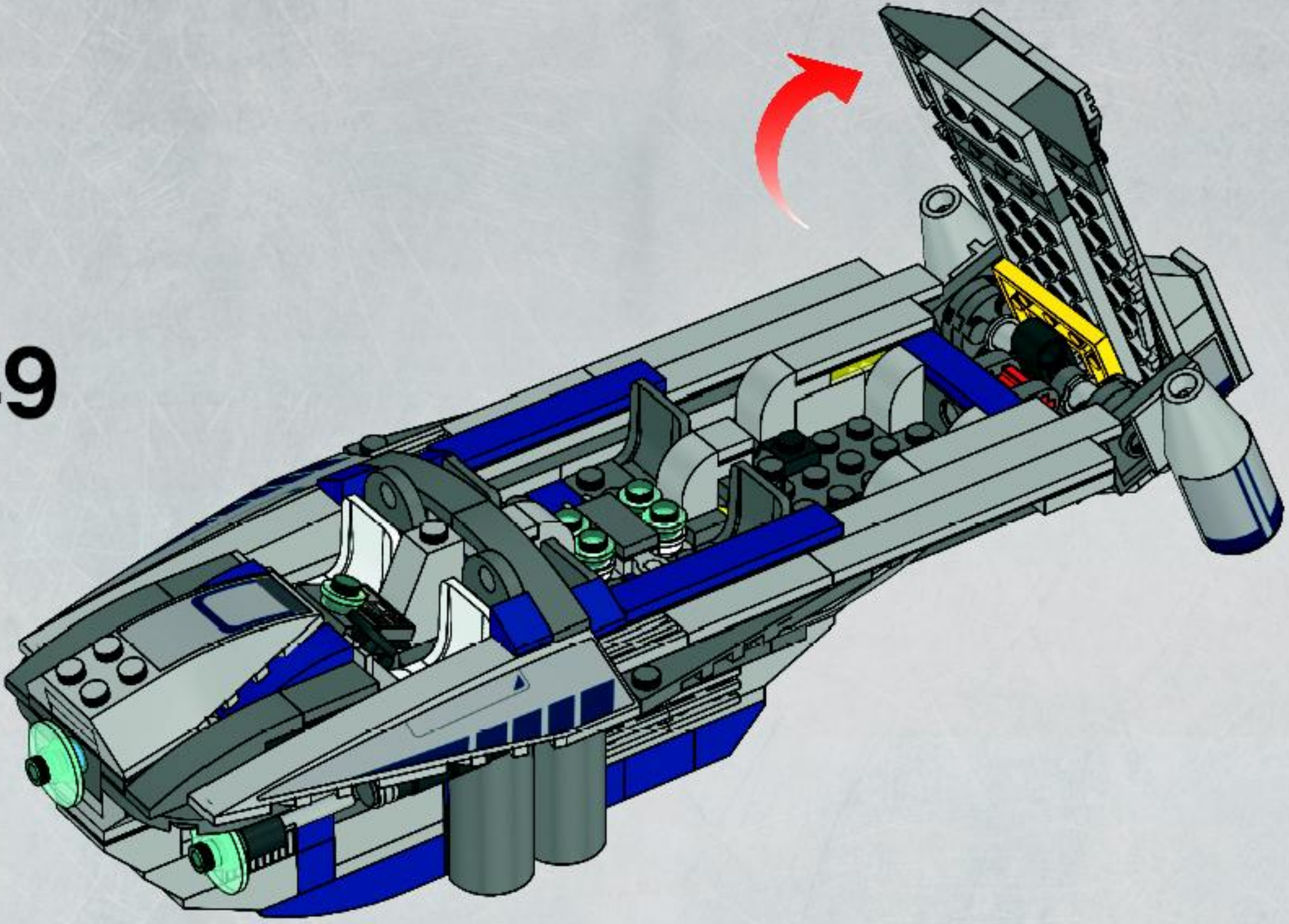

50

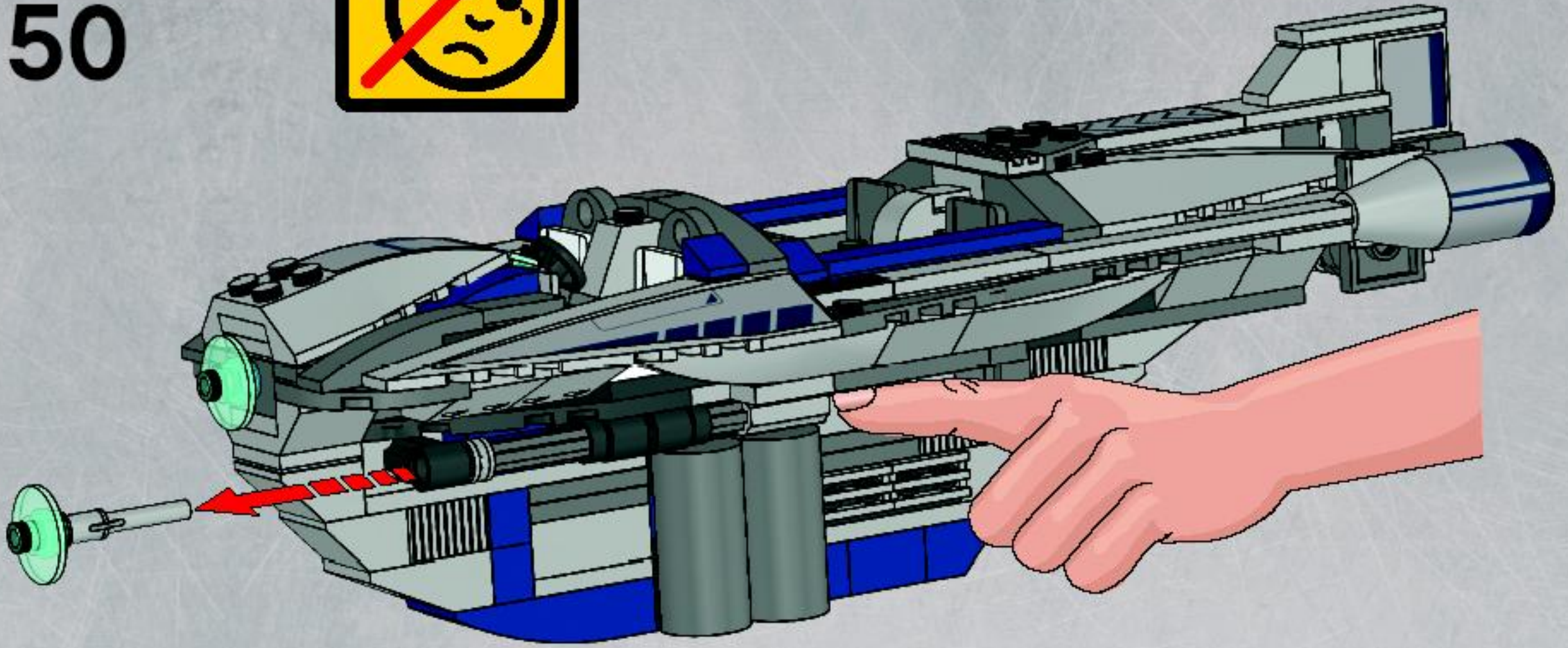

51

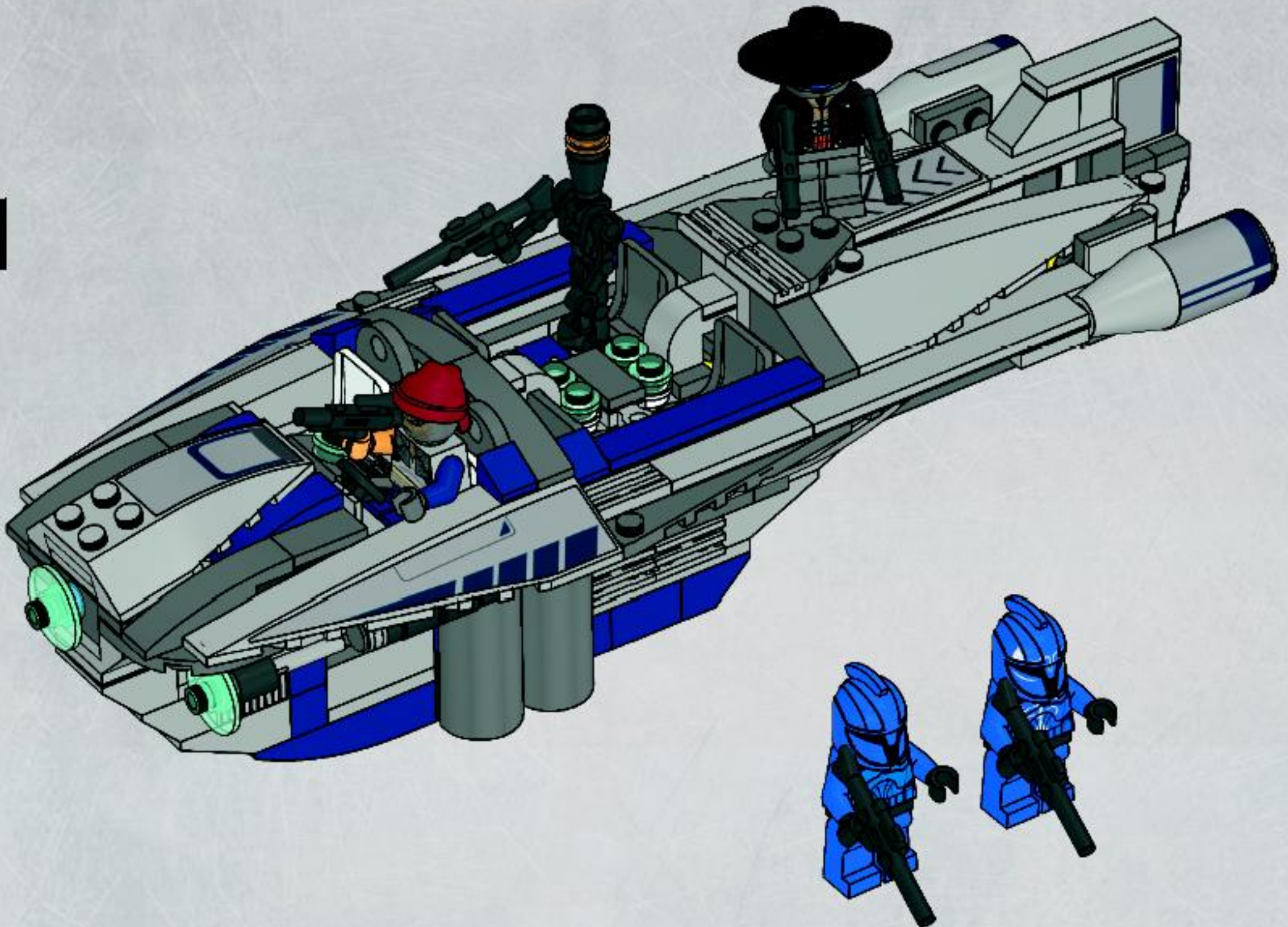

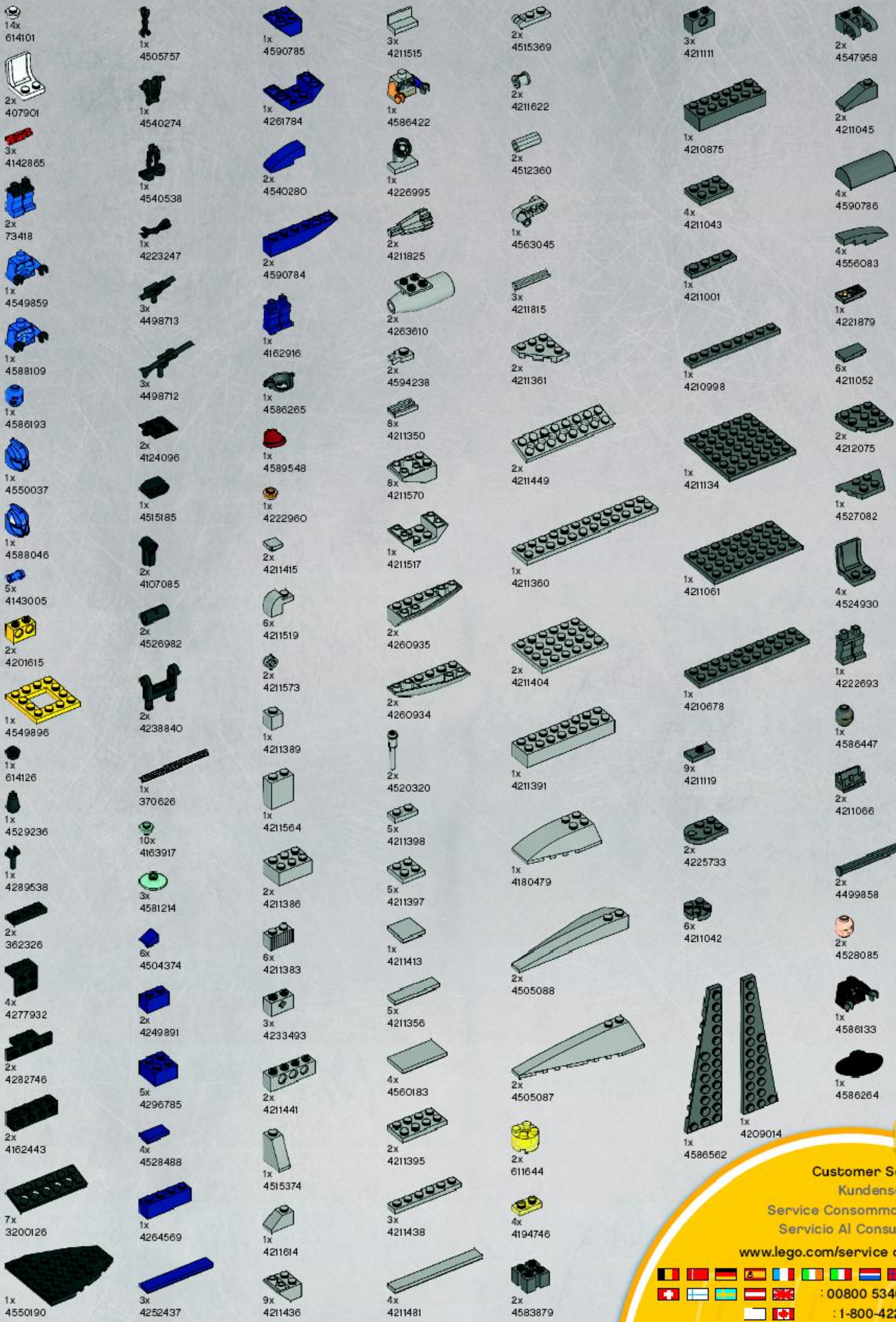

Customer Service
Kundenservice
Service Consommateurs
Servicio Al Consumidor
www.lego.com/service or dial

: 00800 5346 5555
: 1-800-422-5346

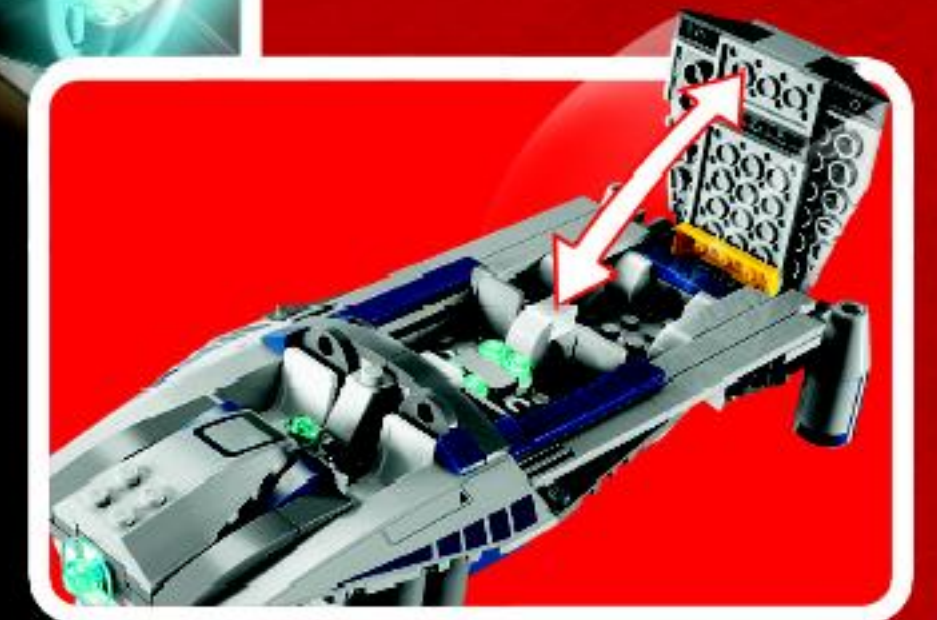



8089



8093



8095



8096



8097



8098



WIN!

Go to www.nielsen.com/LEGO to fill out a survey for a chance to win a cool LEGO® Product. No purchase necessary. Open to all residents where not prohibited.

 www.LEGO.com



www.nielsen.com/LEGO

GEWINNE!

Nimm an der Umfrage auf www.nielsen.com/LEGO teil und hab die Chance ein cooles LEGO® Produkt zu gewinnen!

Die Teilnahme am Gewinnspiel führt zu keinerlei Kaufverpflichtungen. Teilnahme in allen nicht ausgeschlossenen Ländern möglich.

WIN!

Ga naar www.nielsen.com/LEGO, vul een enquêteformulier in en maak kans op een cool LEGO® product.

Geen aankoopverplichting. Iedereen mag deelnemen, uitgezonderd ingezetenden van landen waar een enquêteverbod geldt.

GAGNE!

Visite www.nielsen.com/LEGO pour répondre à un questionnaire et avoir une chance de gagner un produit LEGO® très cool!

Aucune obligation d'achat. Ouvert à tous les résidents des pays autorisés.

当てよう!

www.nielsen.com/LEGOにアクセスして、アンケートにご記入ください。当選者にはレゴ製品を差し上げます。

お買い上げの必要はありません。購止されていない限り、すべての店舗にご利用いただけます。