

LEGO



8678



1

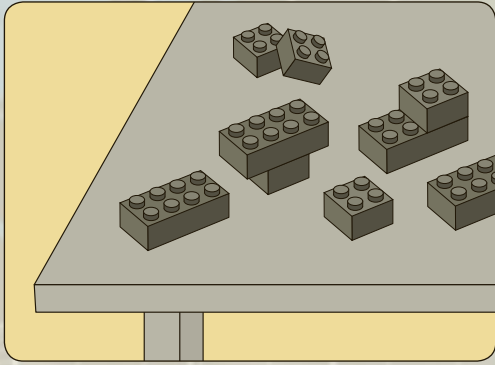
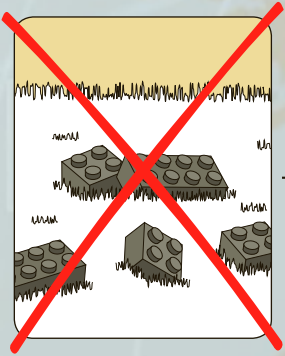

2



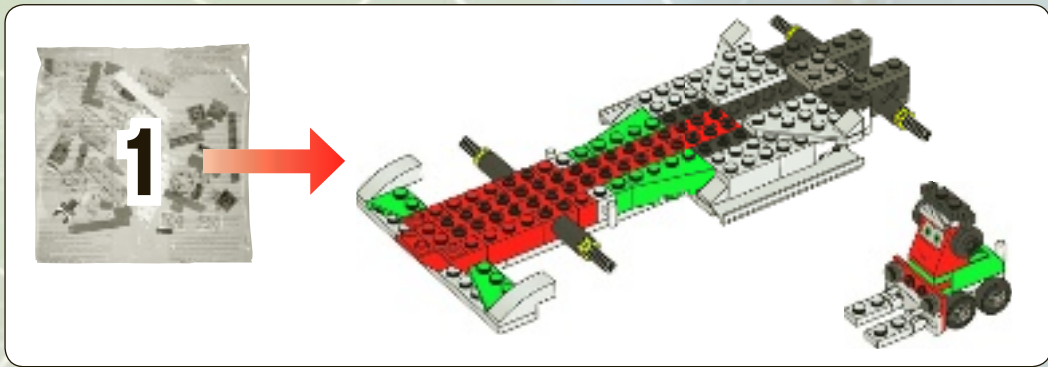

1





2x

2

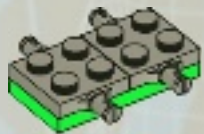

1x



1x

3

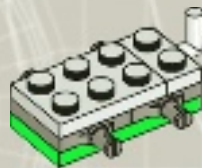



1x



1x

4



1x

5

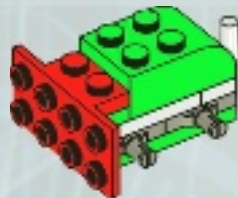



1x



2x

6

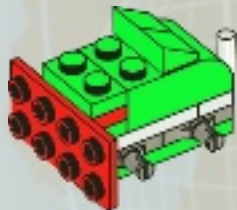

1x

7





2x



1x

8



2x



1x

9

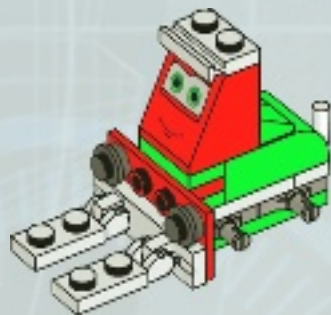



2x

10

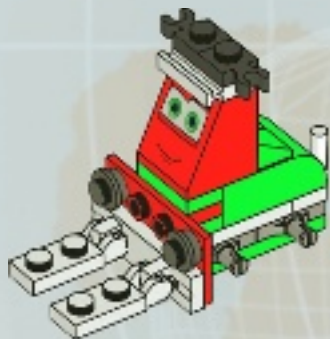

2x

11

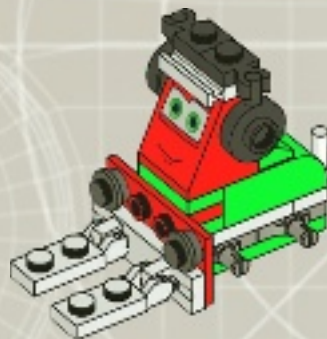



4x



4x

12

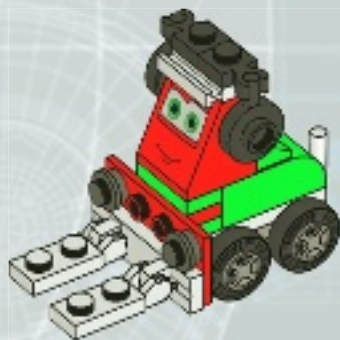

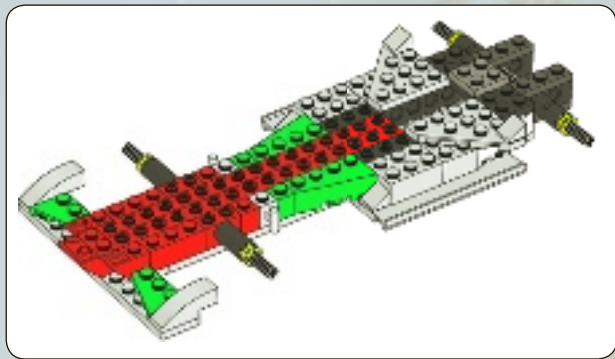

1

10

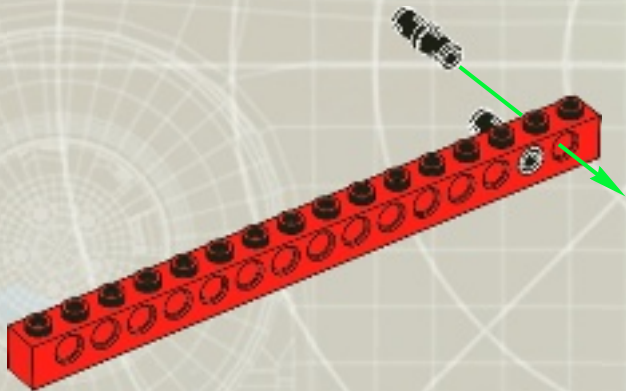



2x

2



1x

3



2x

4





5

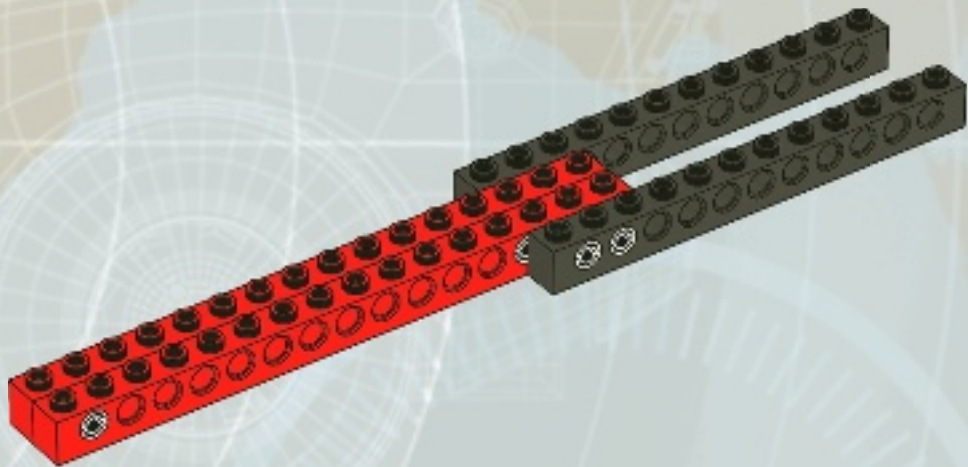

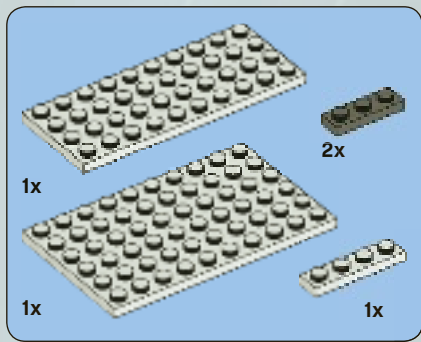

6

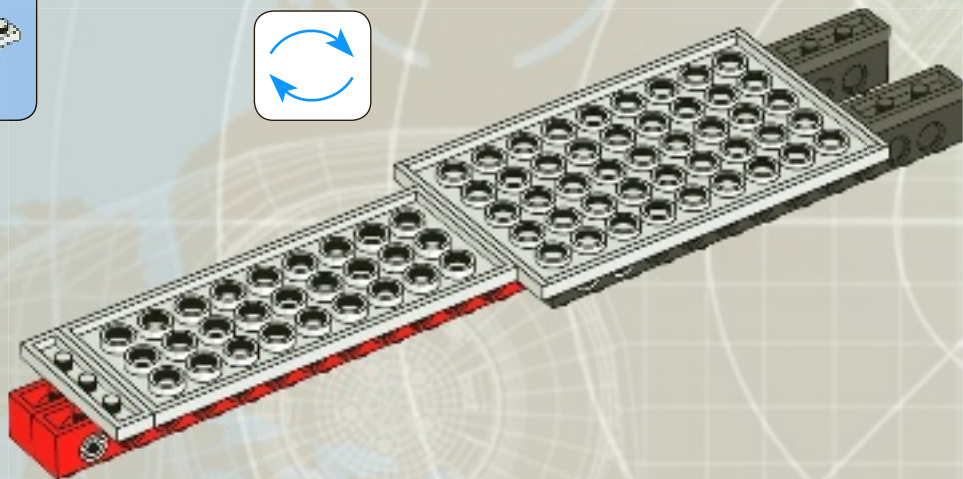

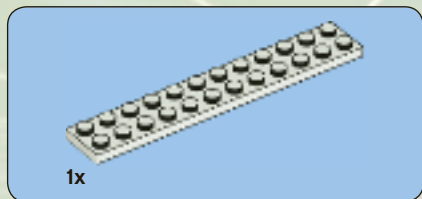

7

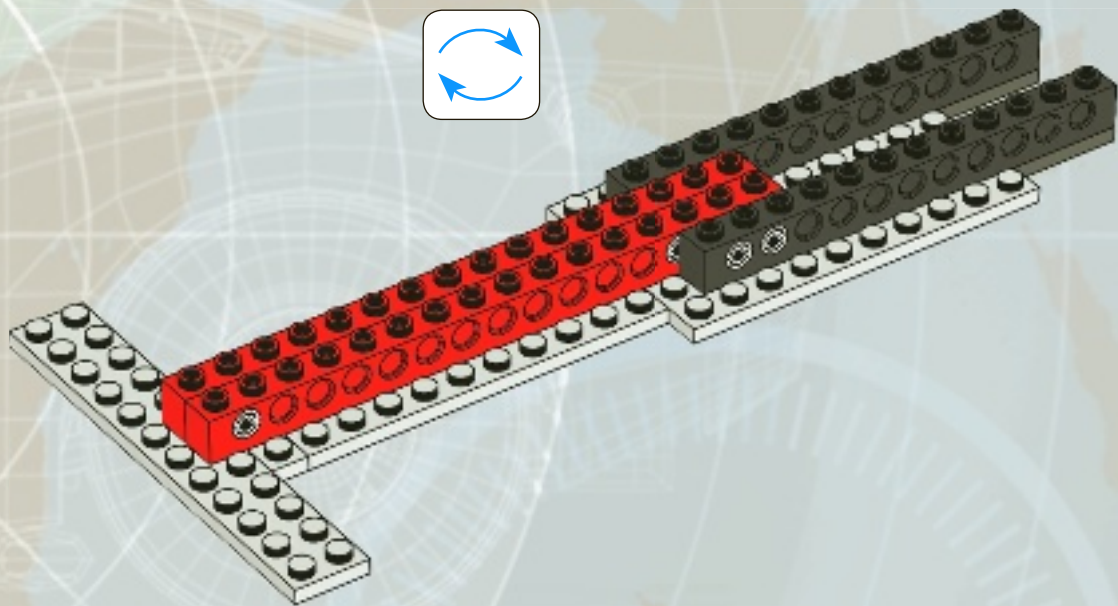

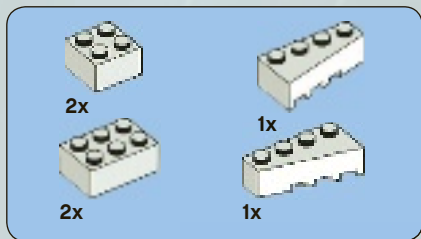

8

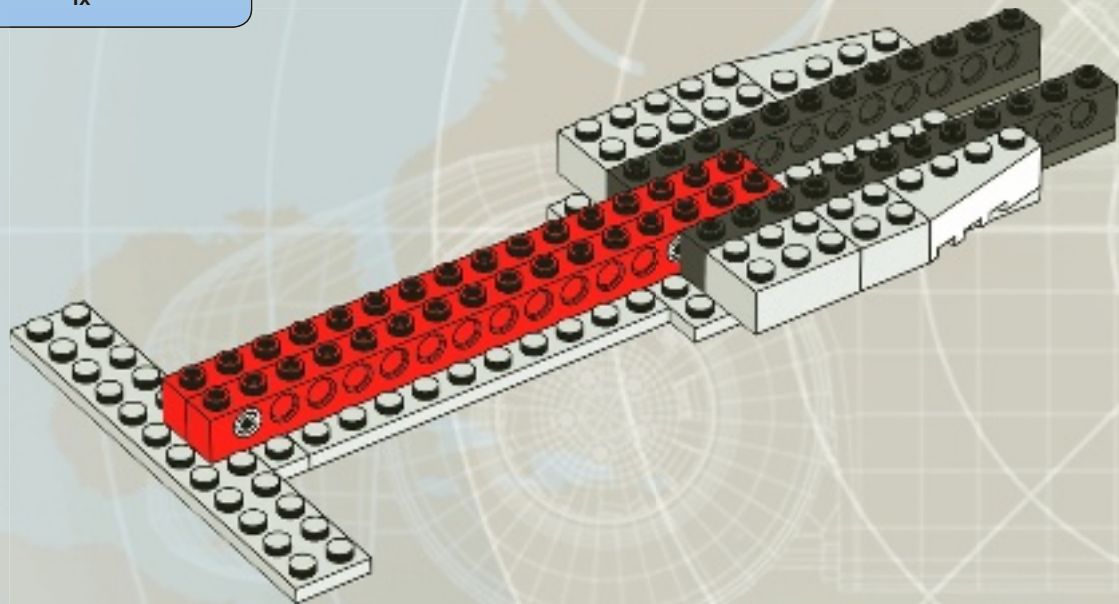

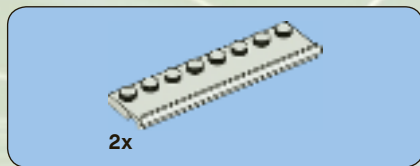

9

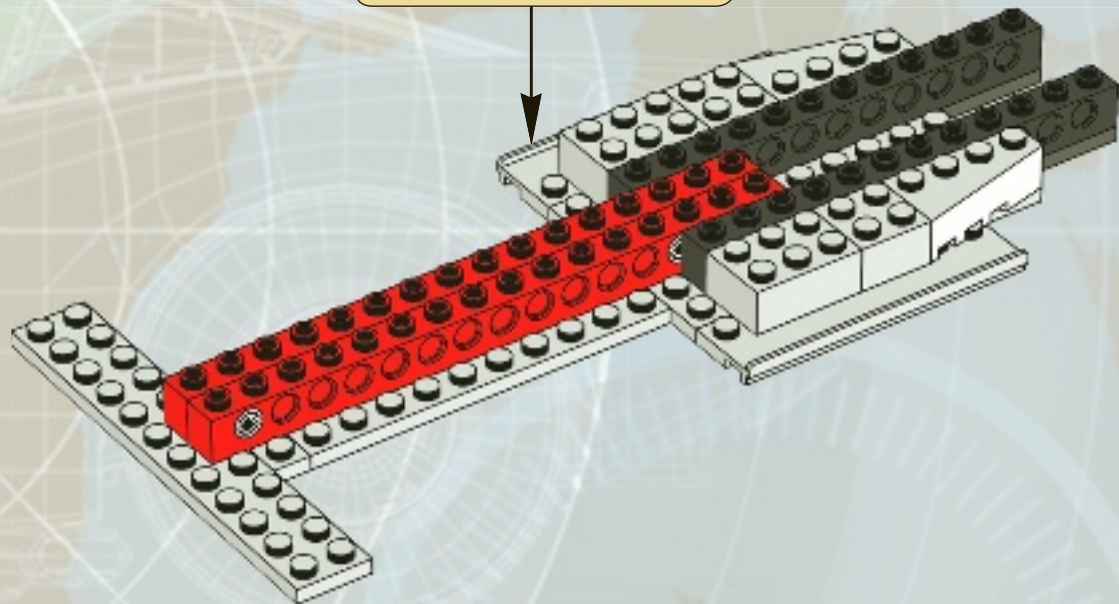
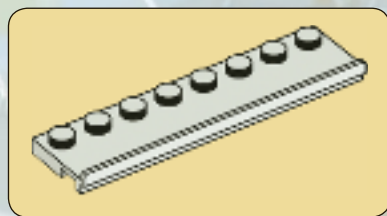

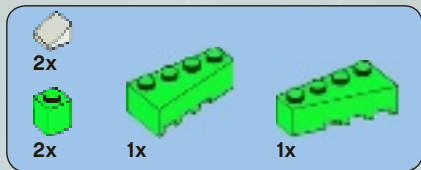

10

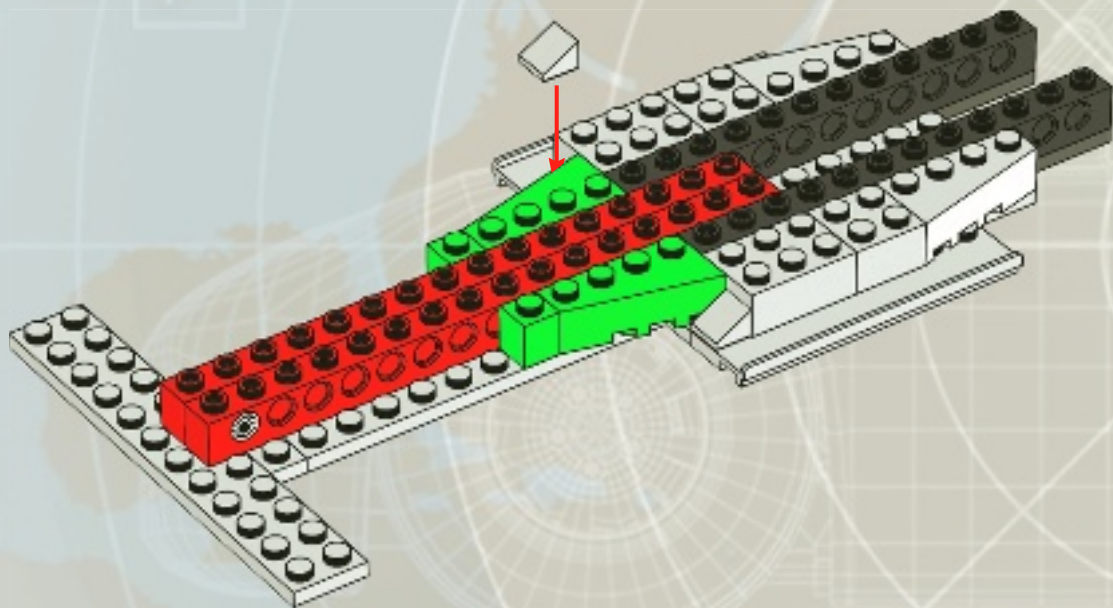



2x



1x

12

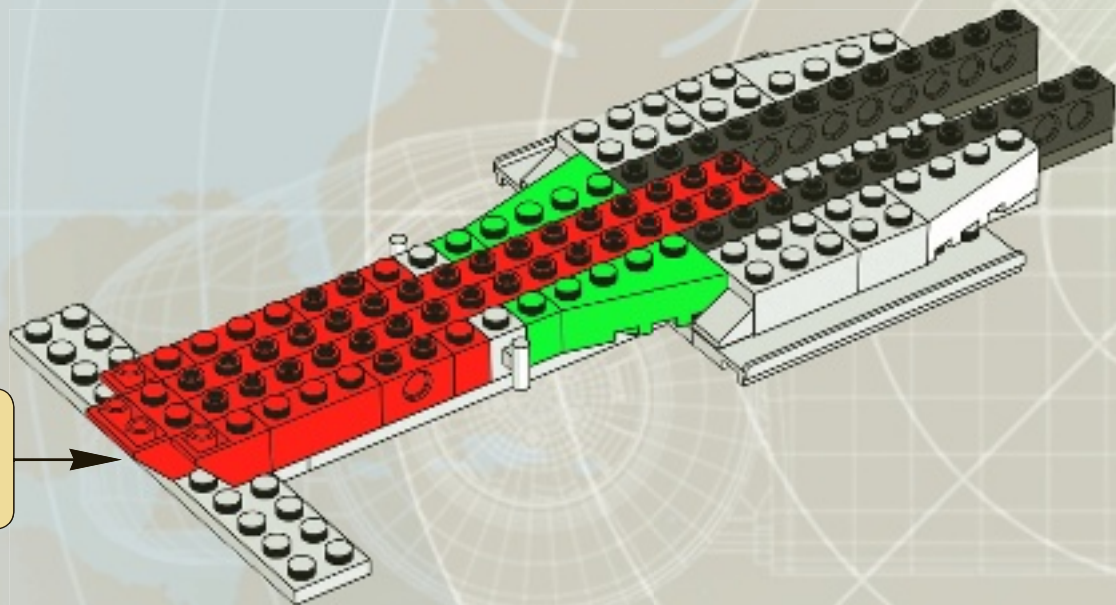

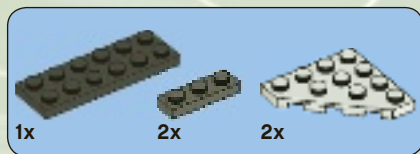

13

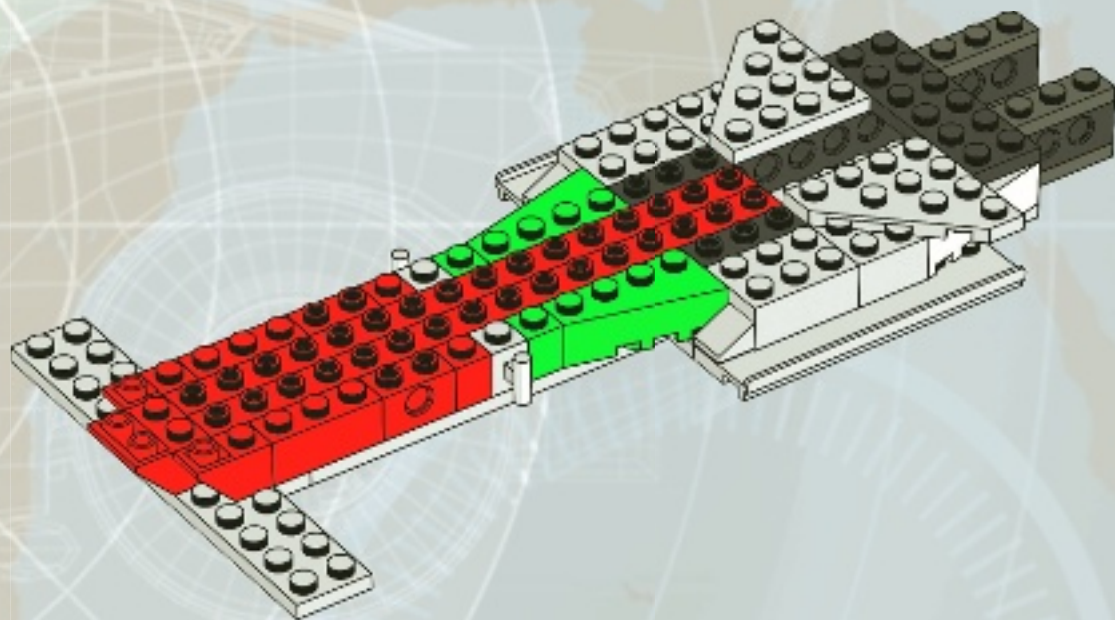



2x



1x

14

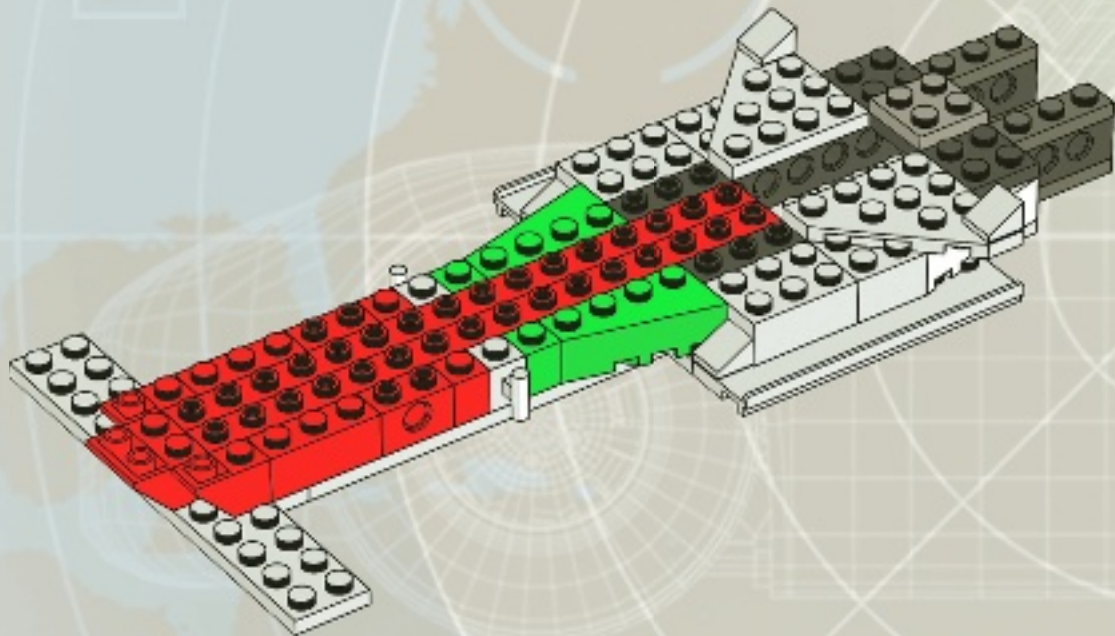

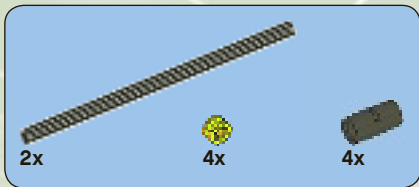

2

target
acquired

15

1

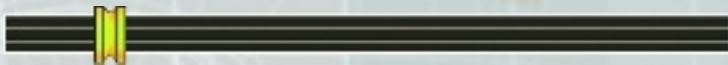

1:1

2

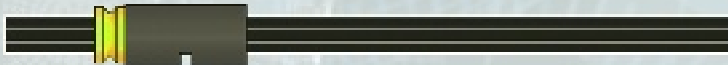

1:1

2x

waypoint 7

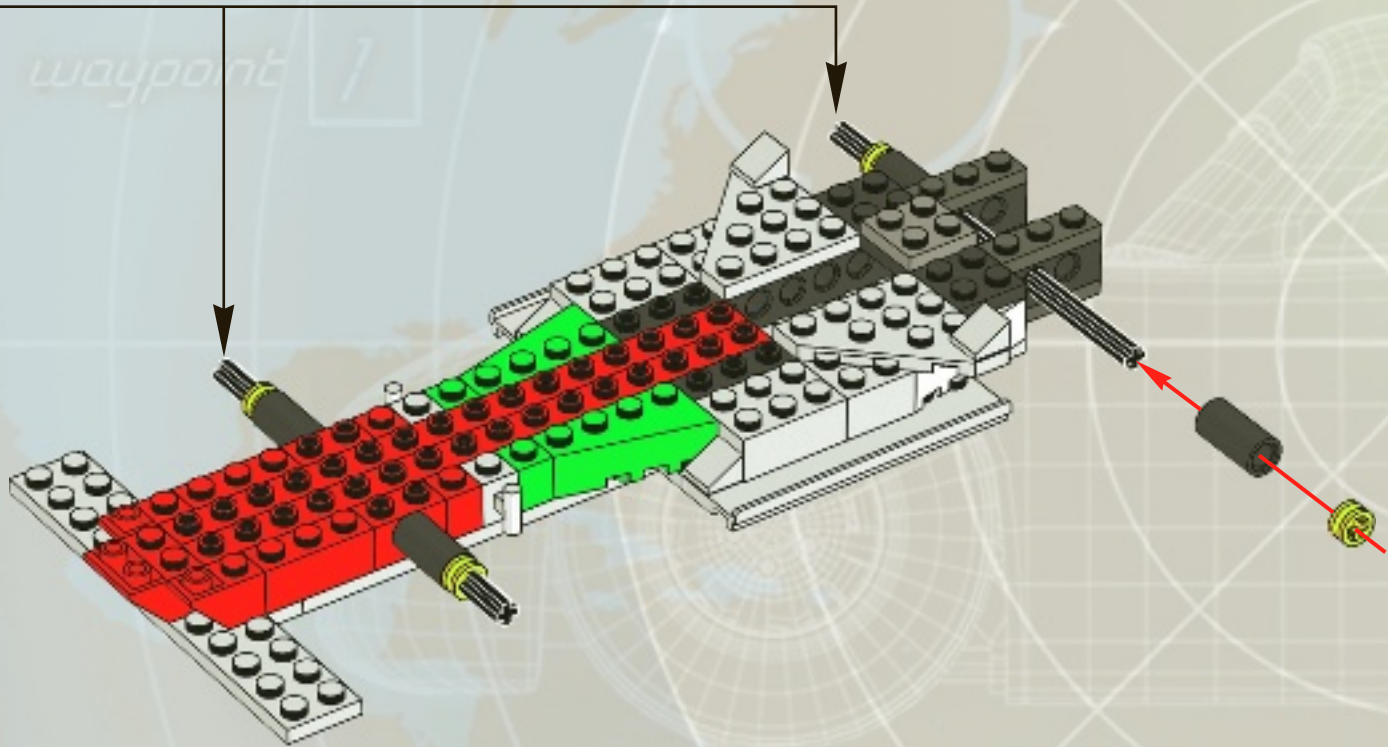



16

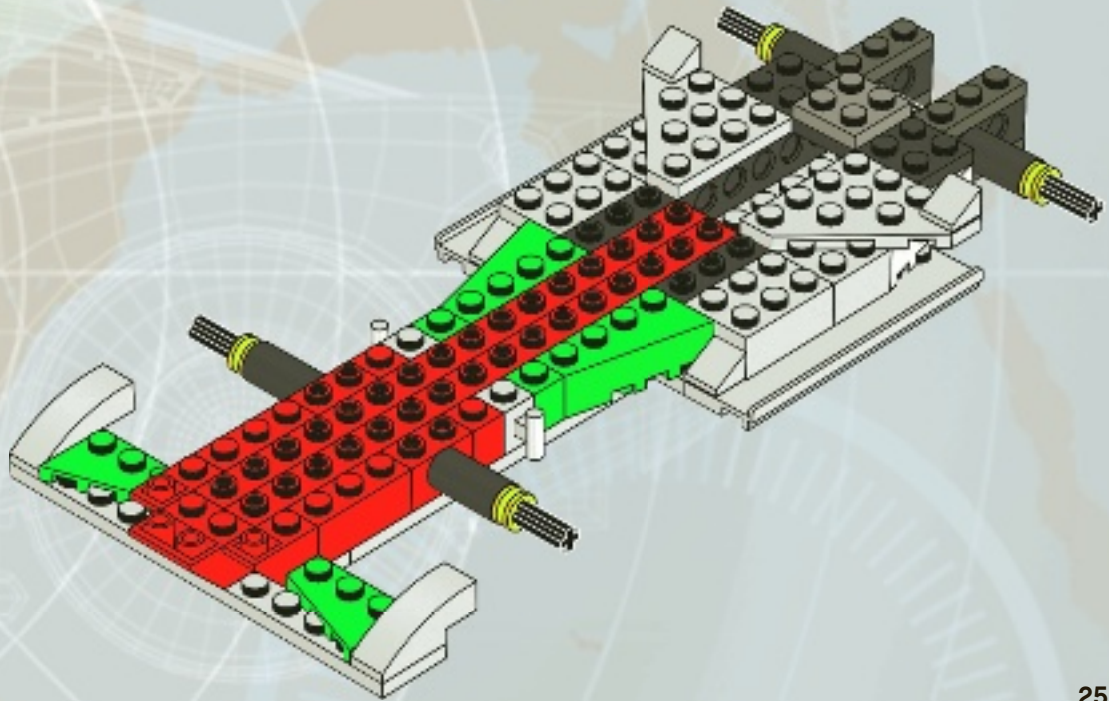

2

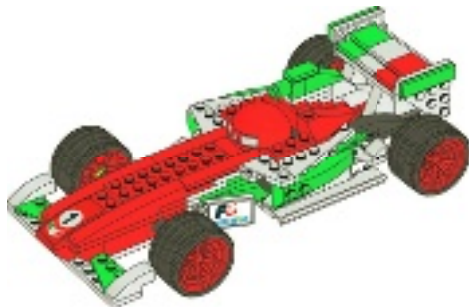

2x



2x



2x

17

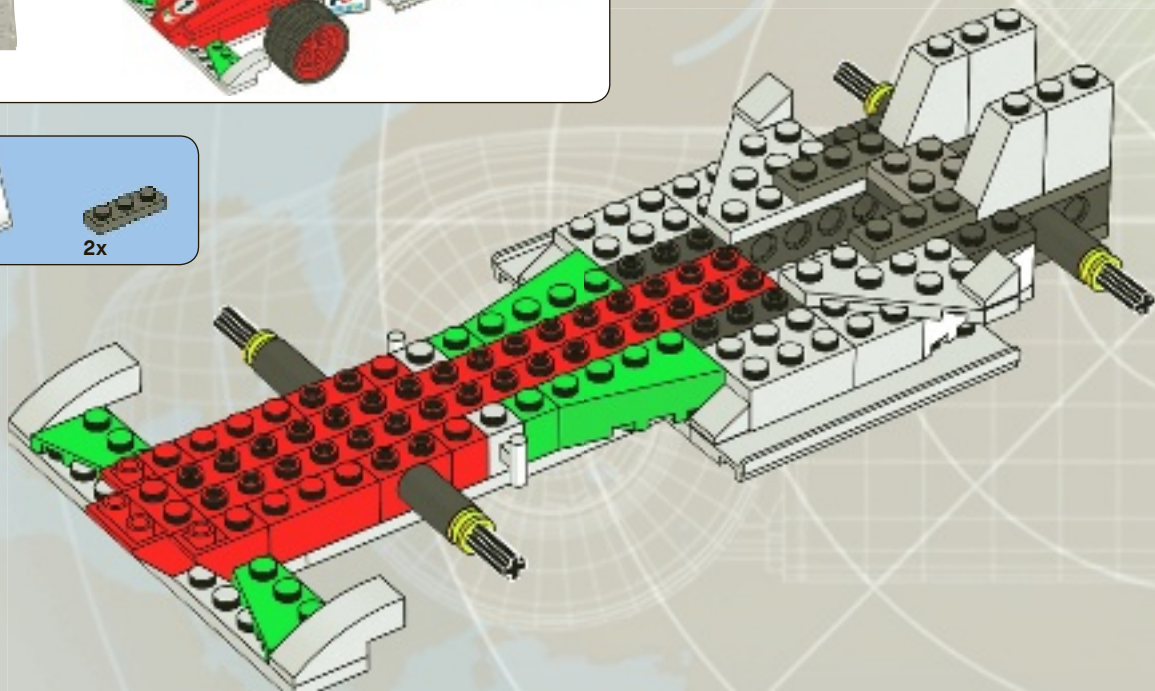



1x



2x

18

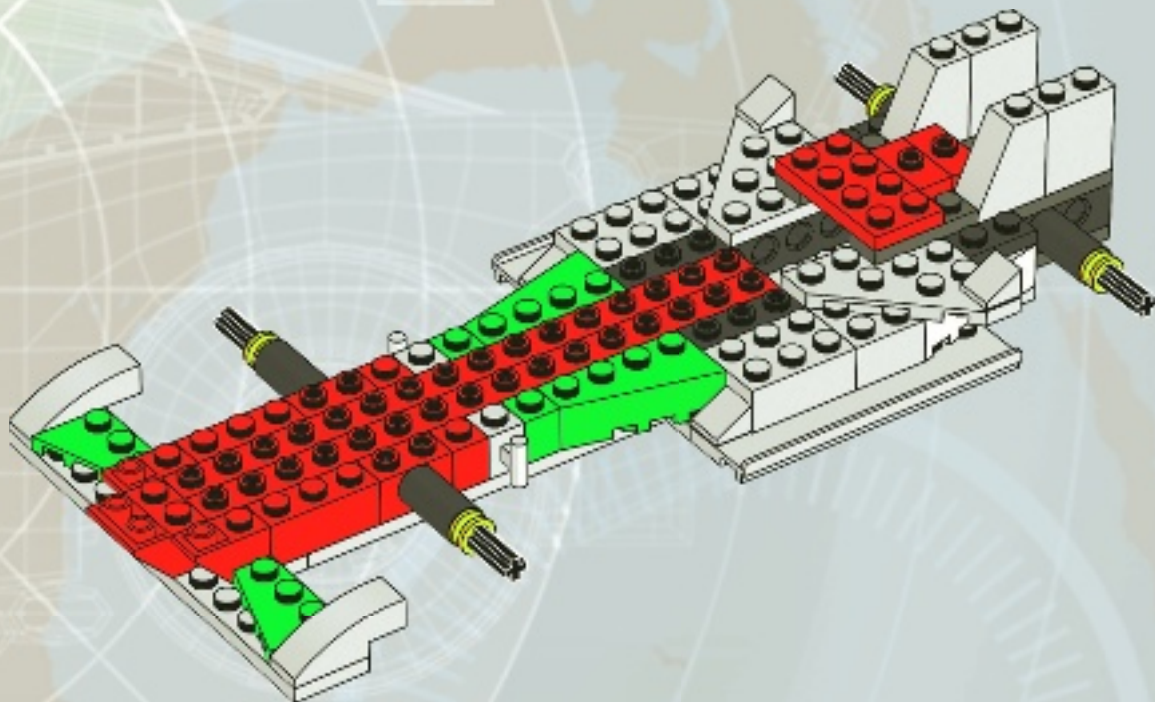



19

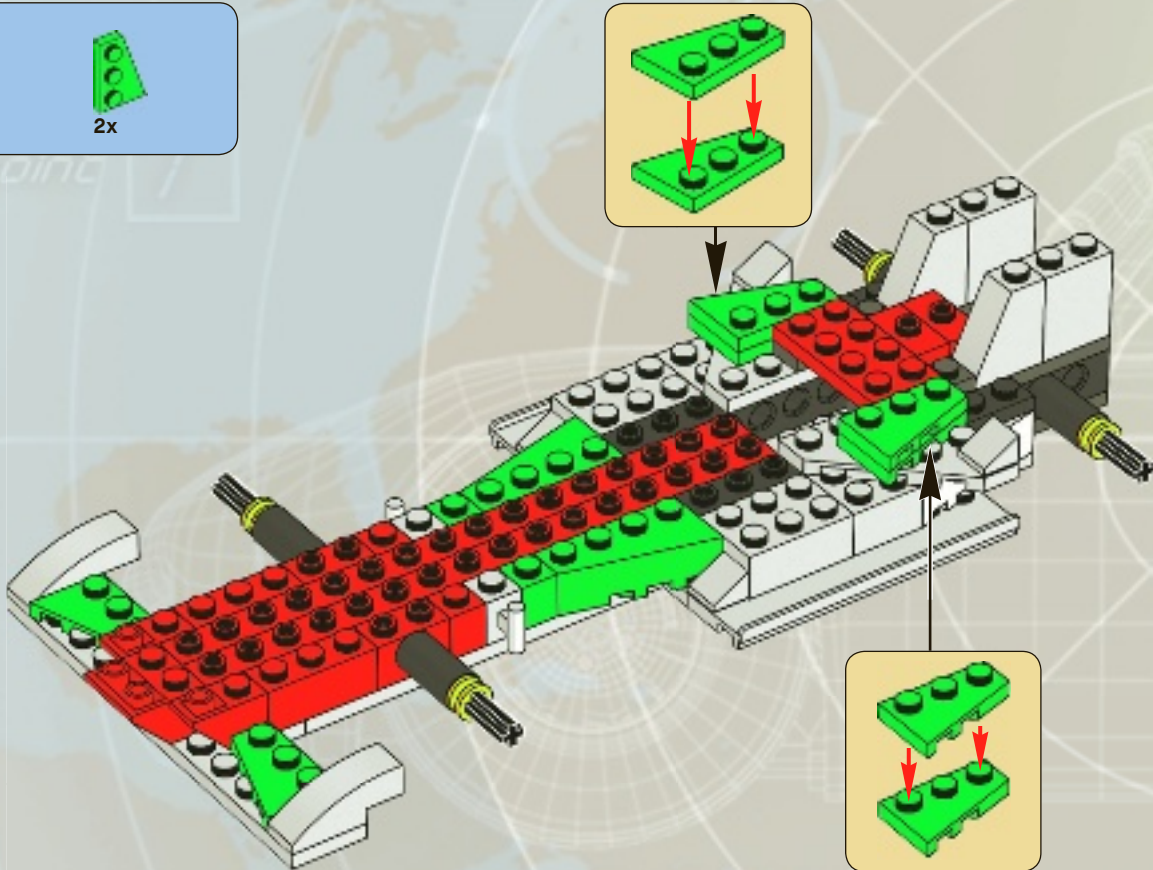

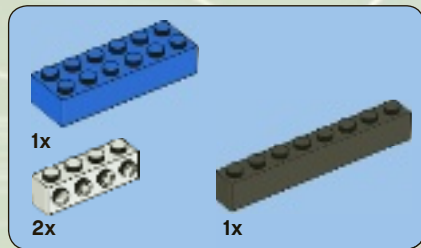

20

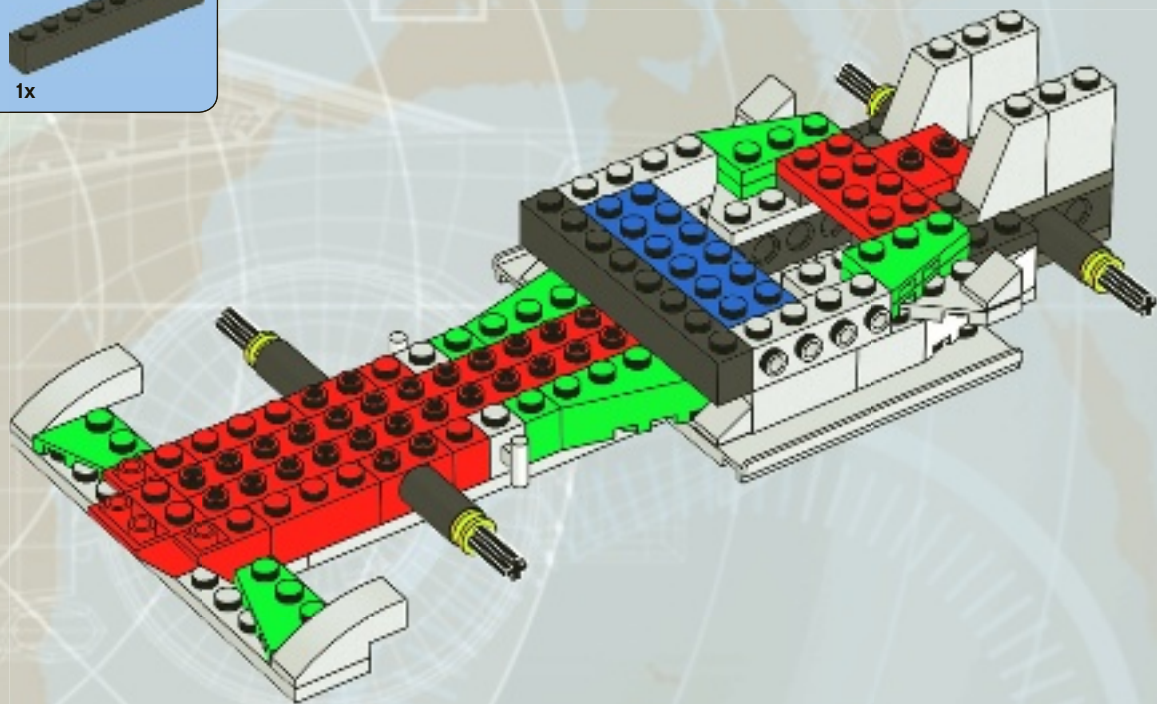



21

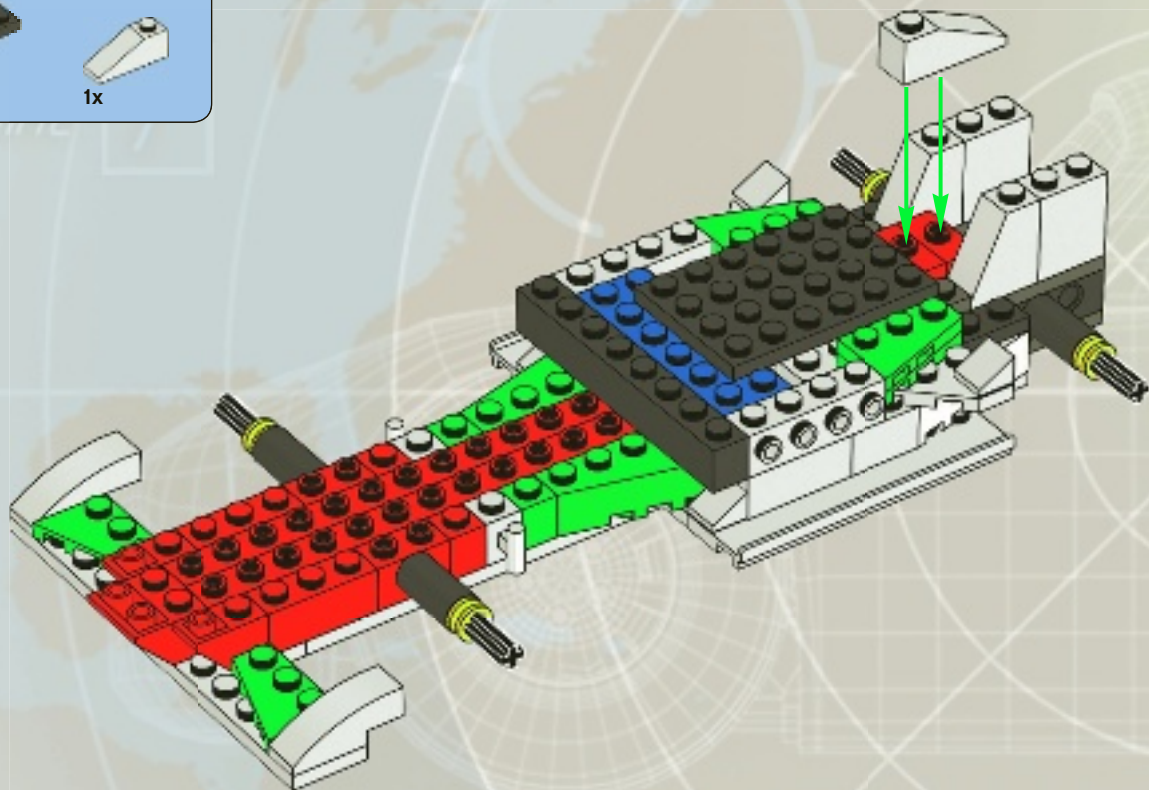



2x

22

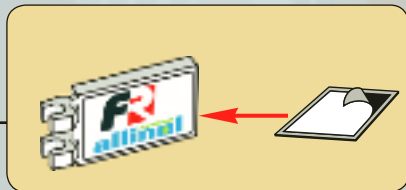
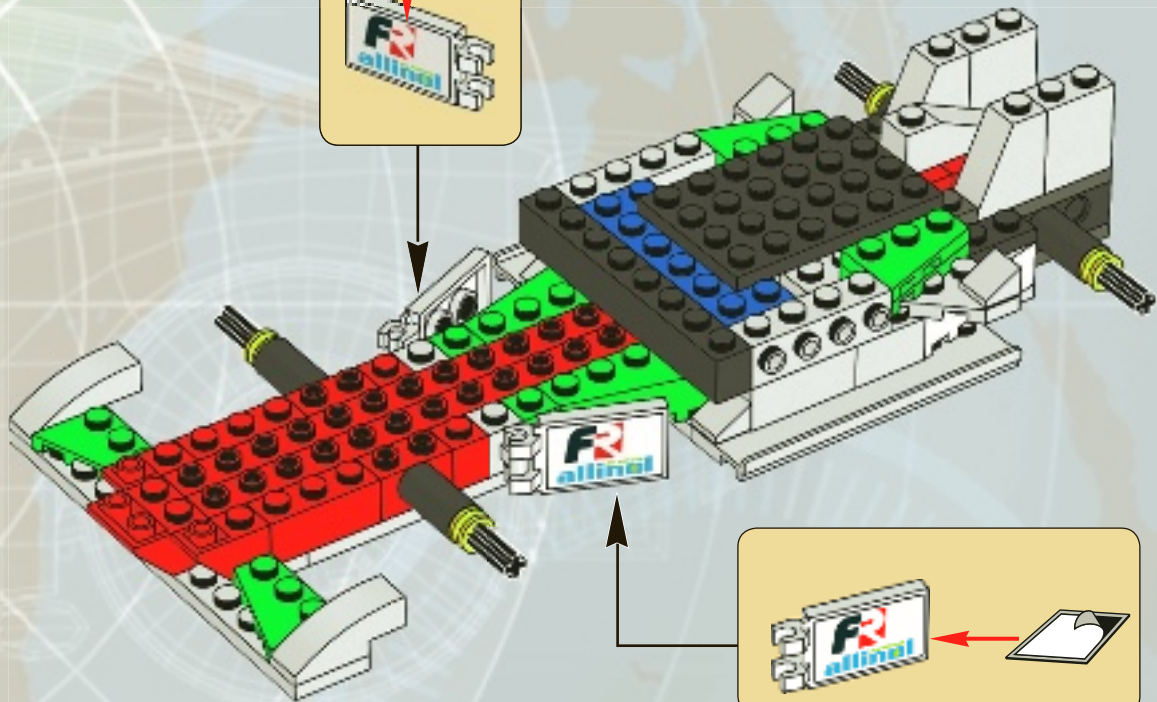
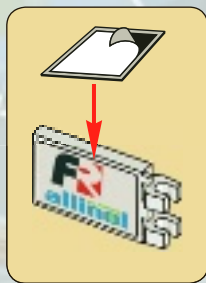

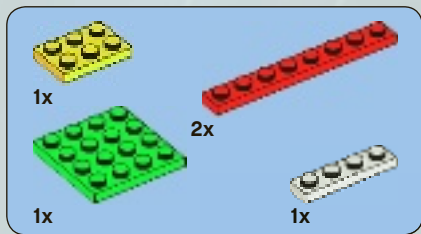

23

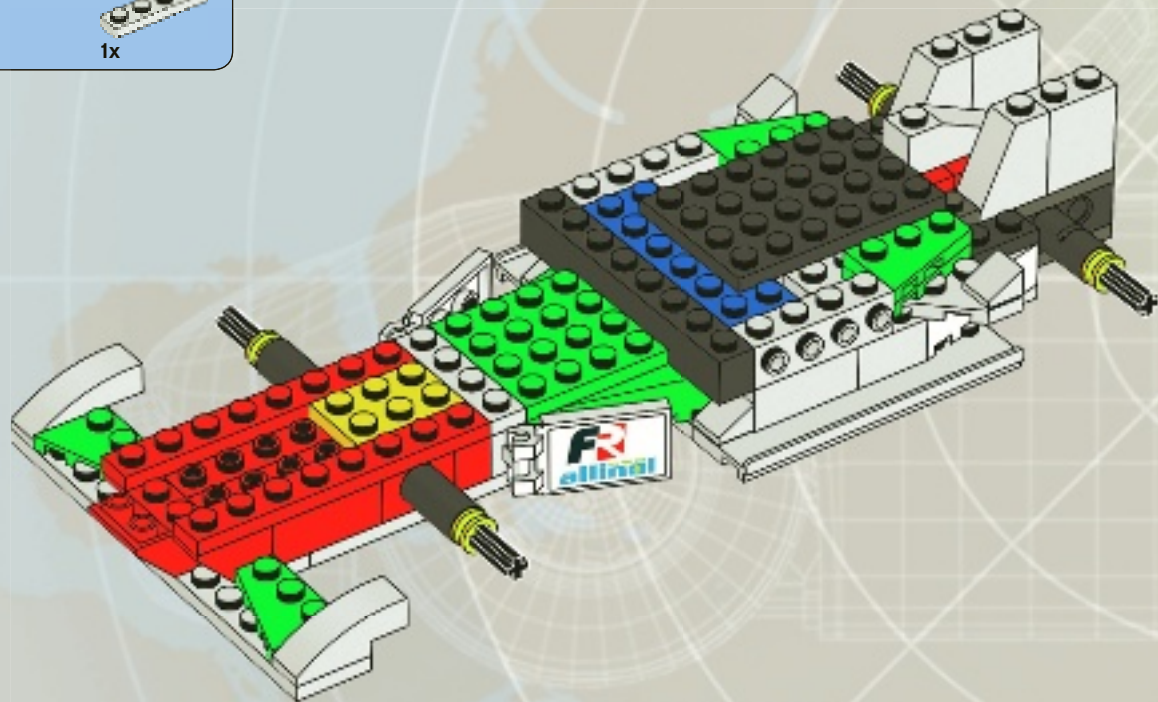

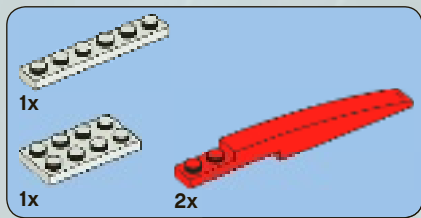

25

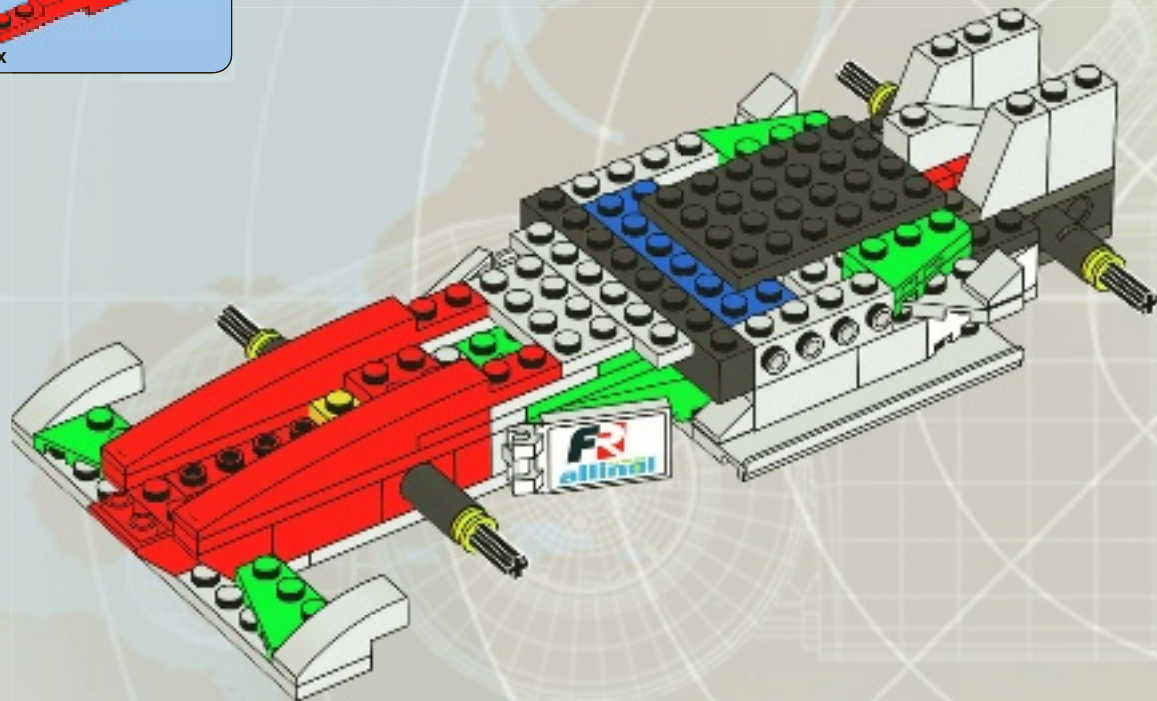

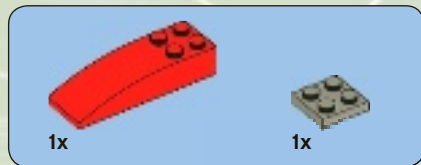

26

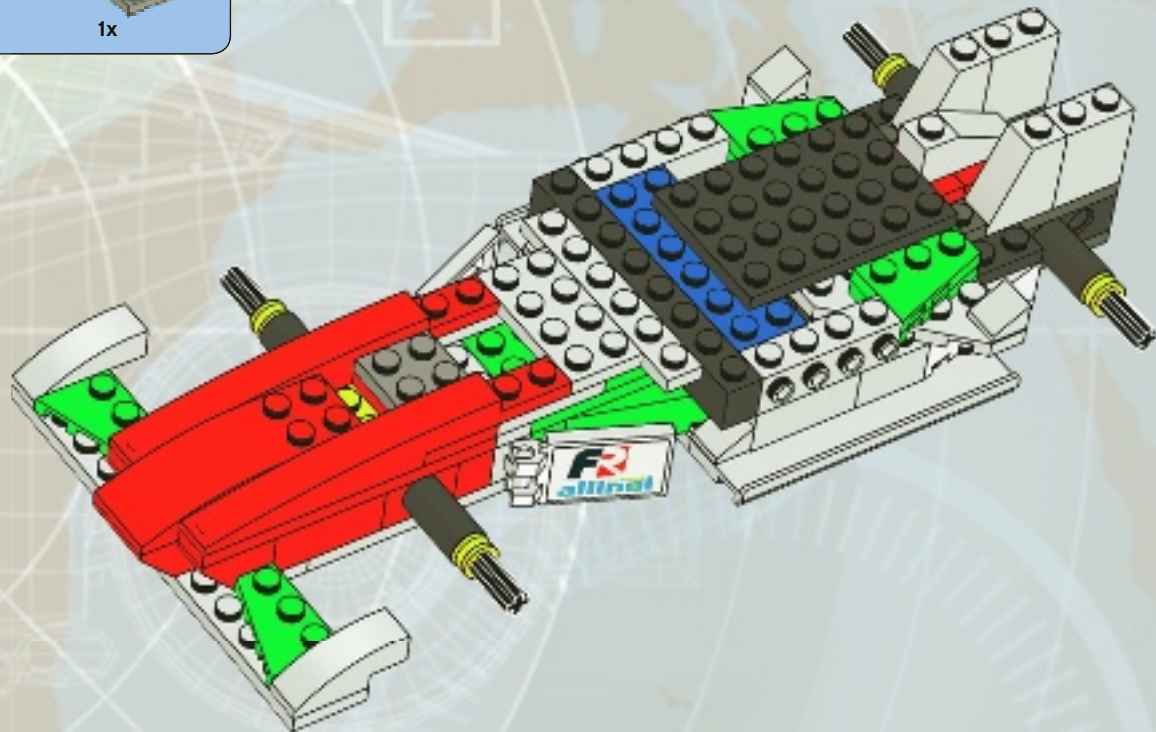

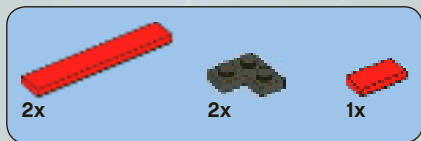

27

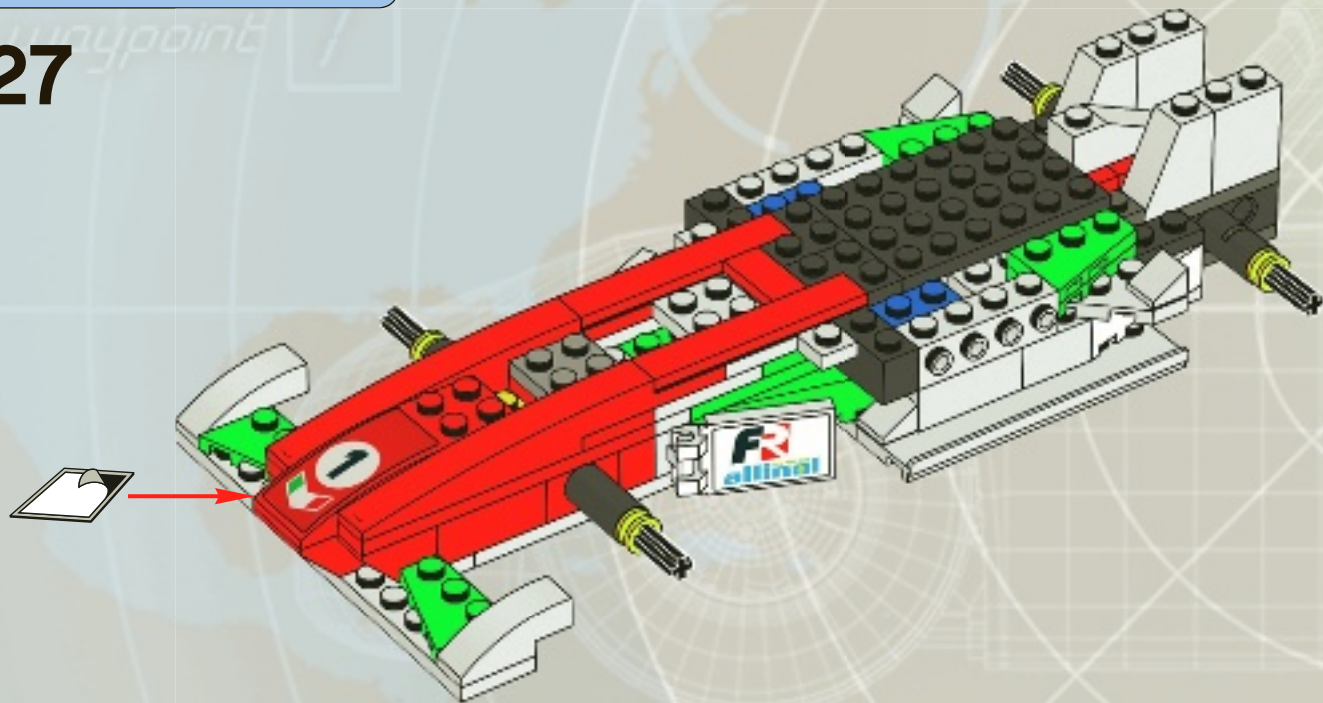

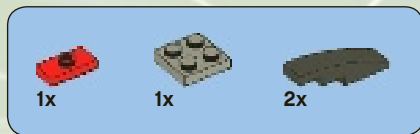

28

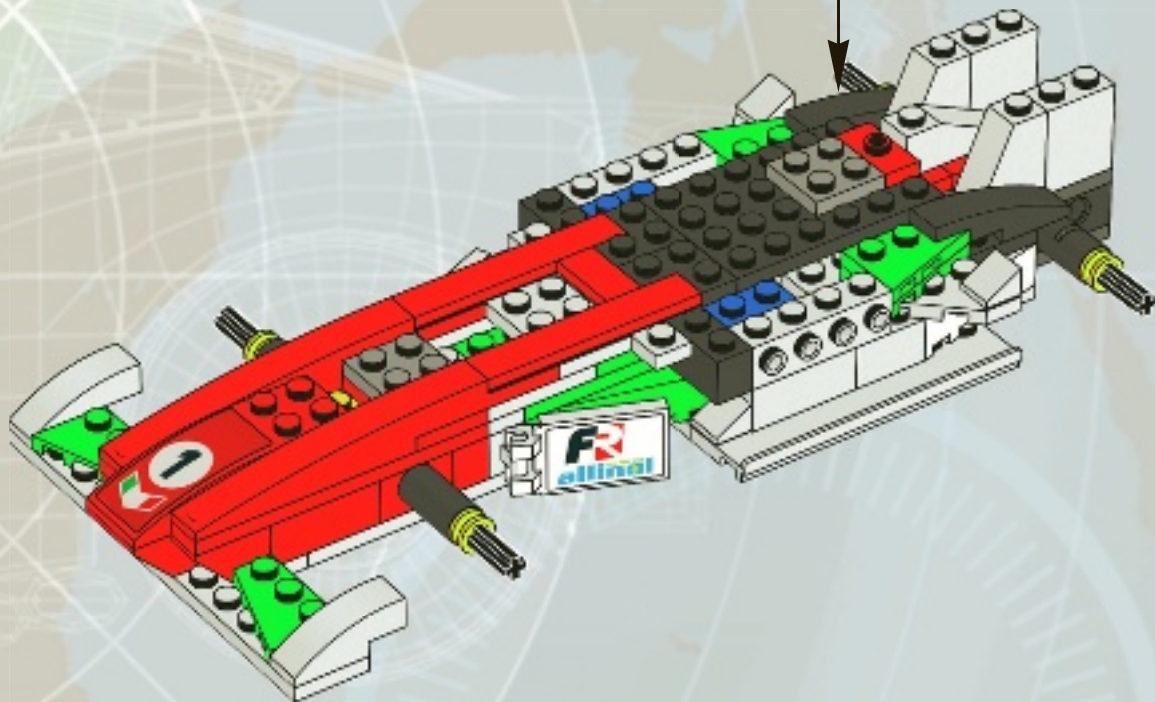

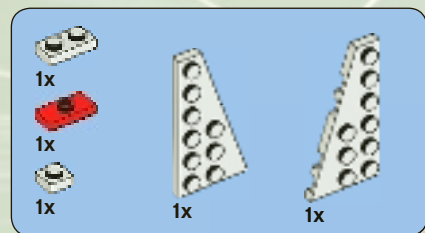

30

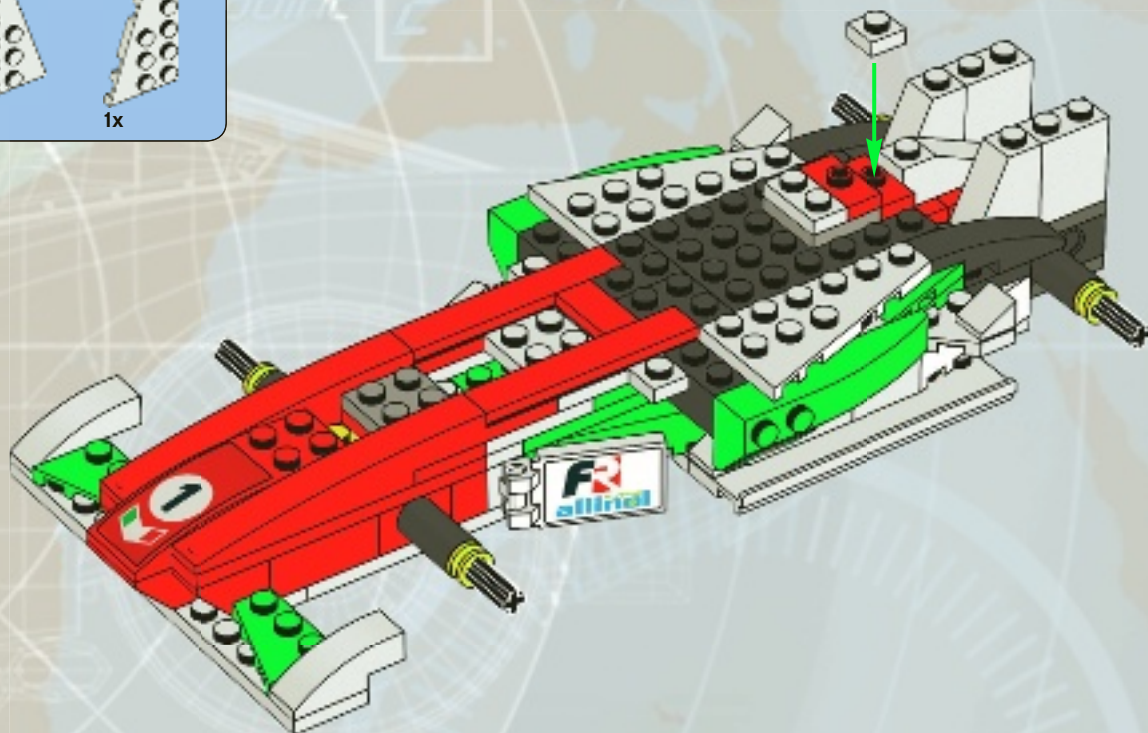

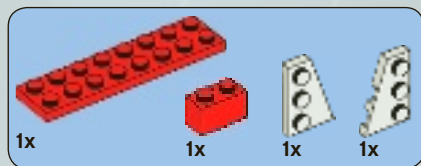

31

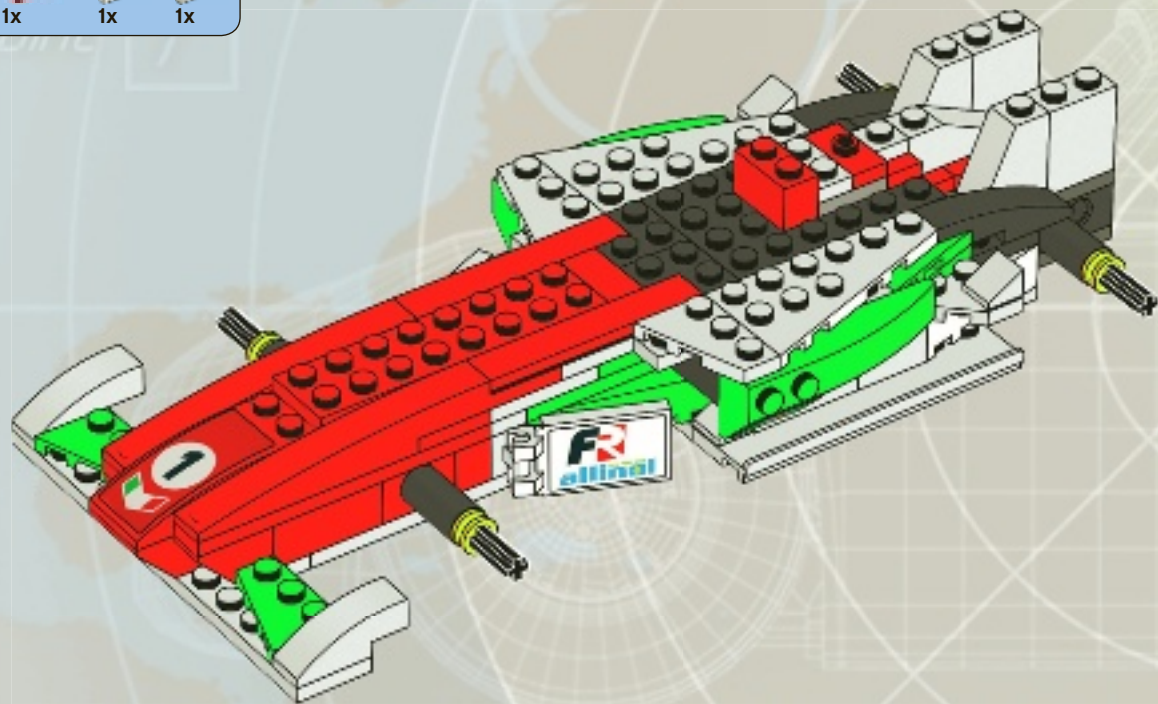

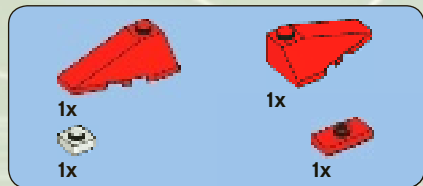

32

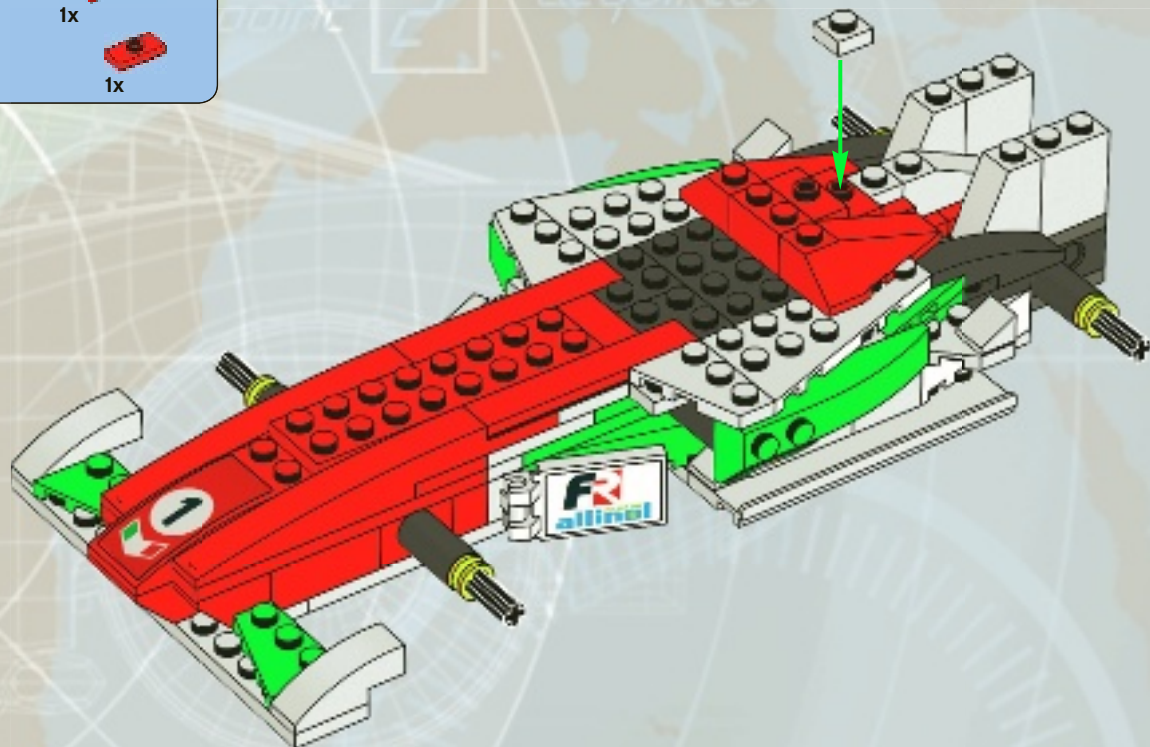



1x



2x



1x



1x

33

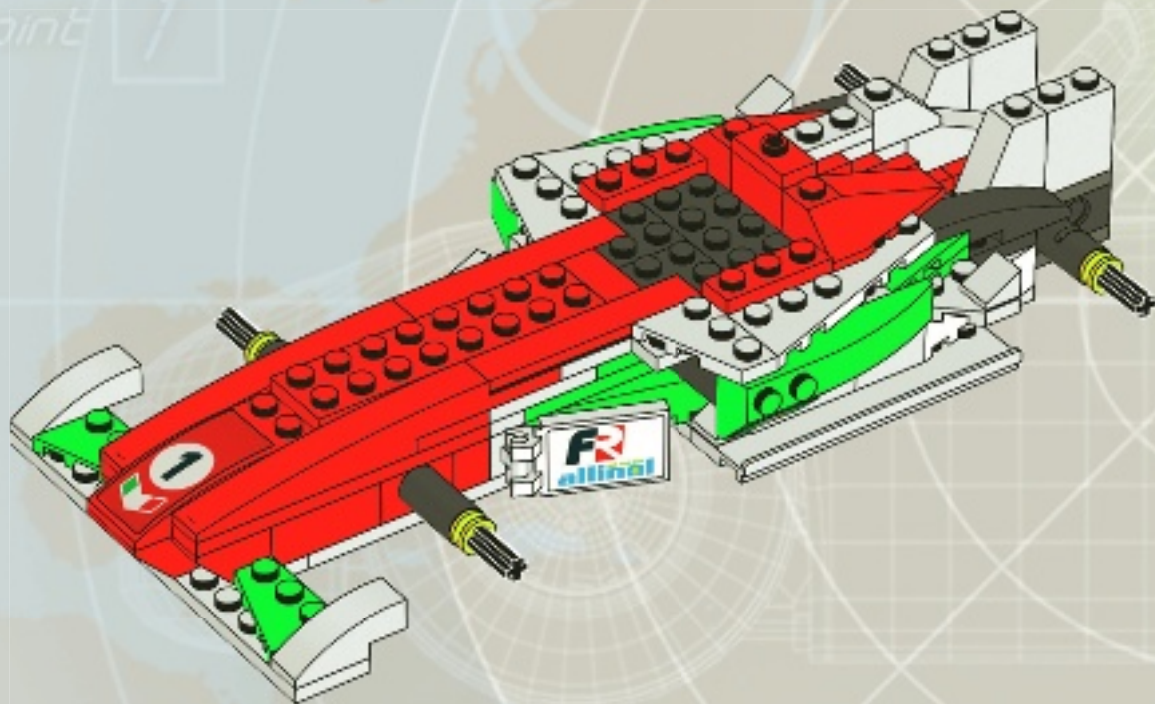



1x

34

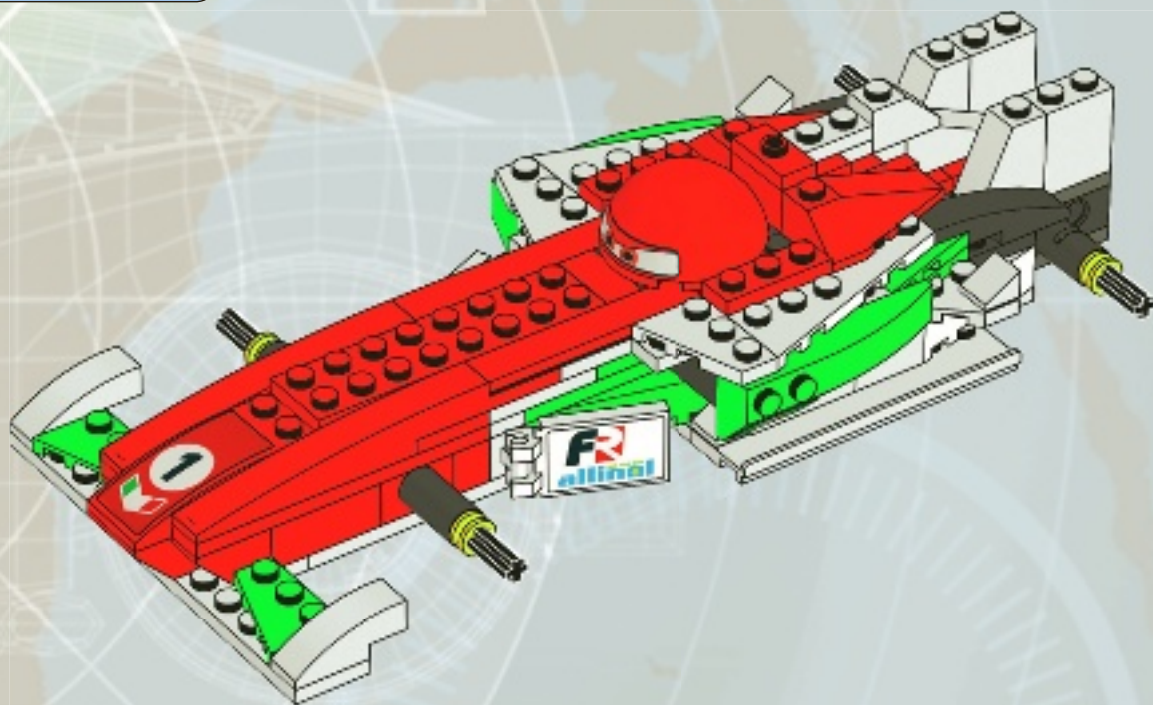

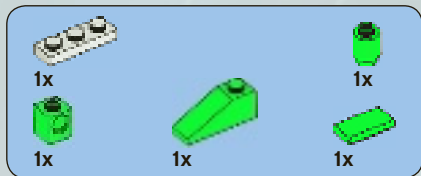

35

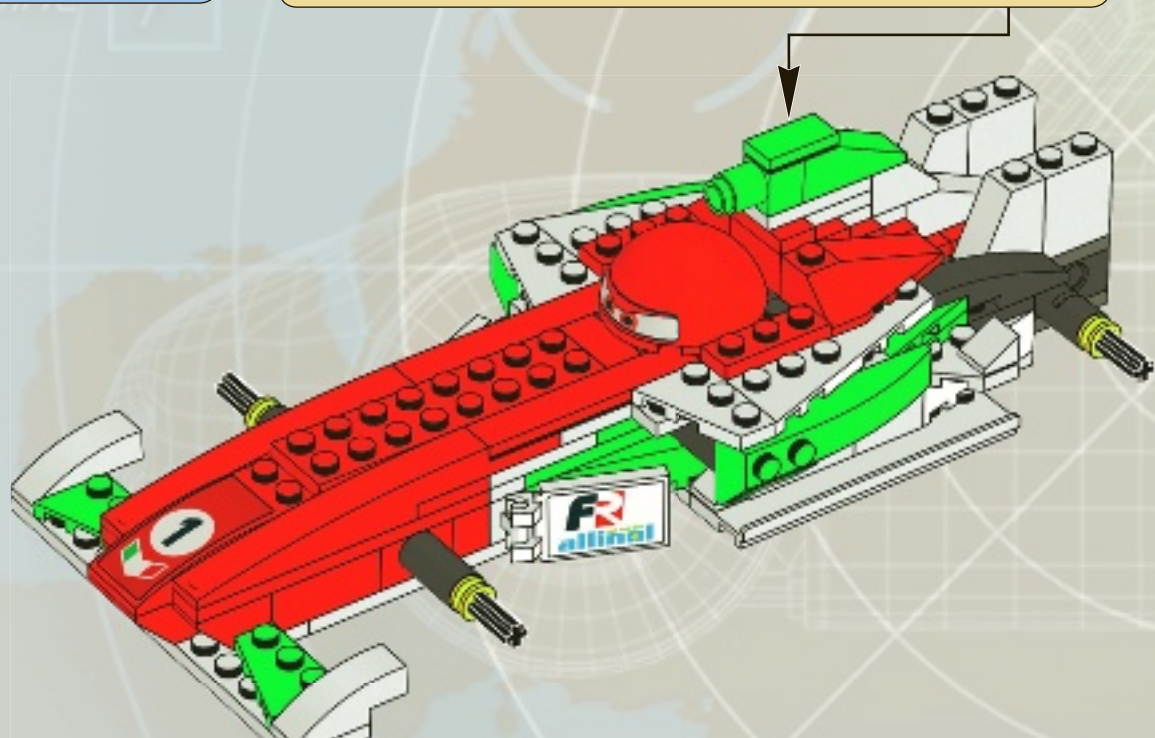

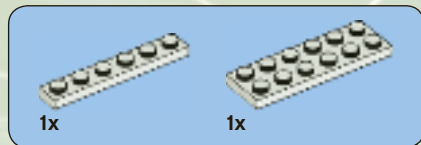

36

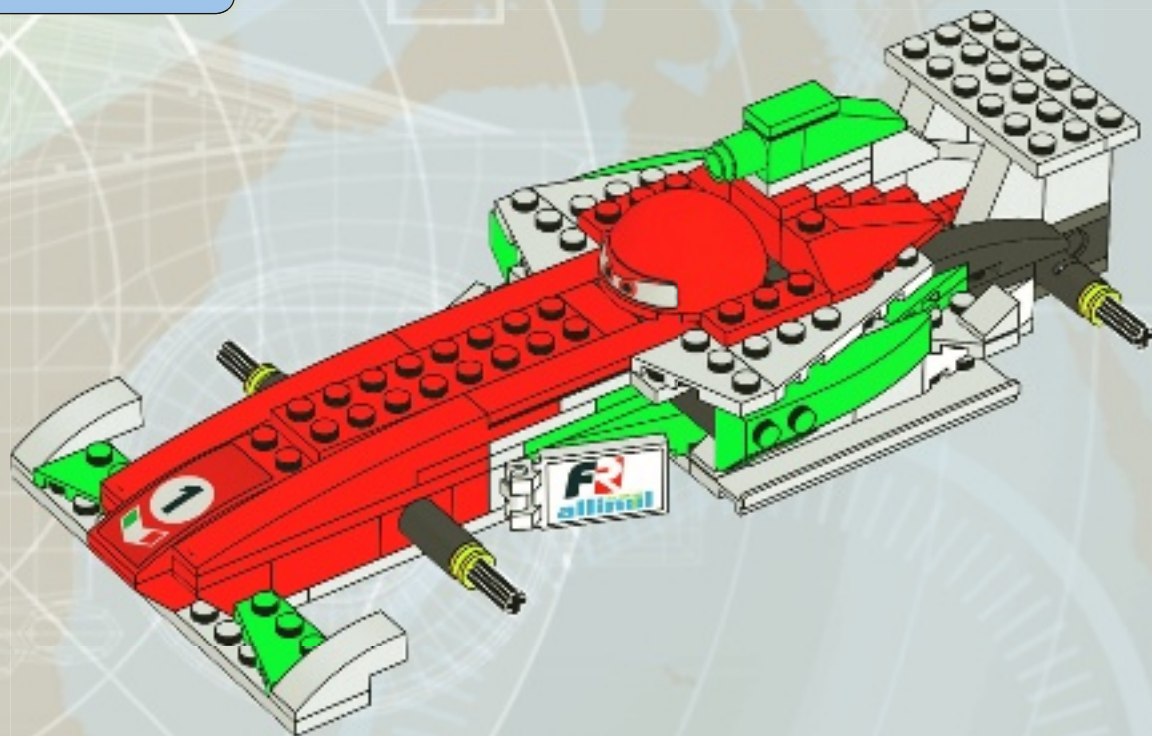



2x



3x



2x

37

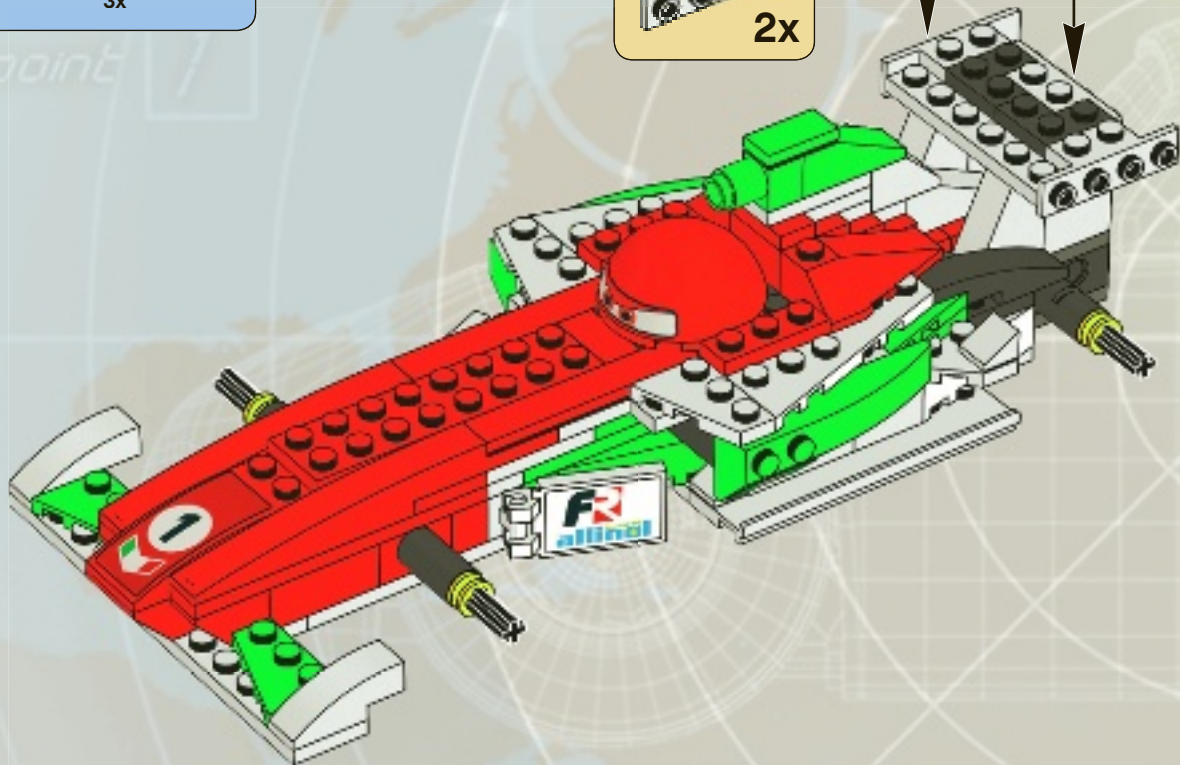

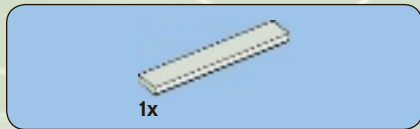

38

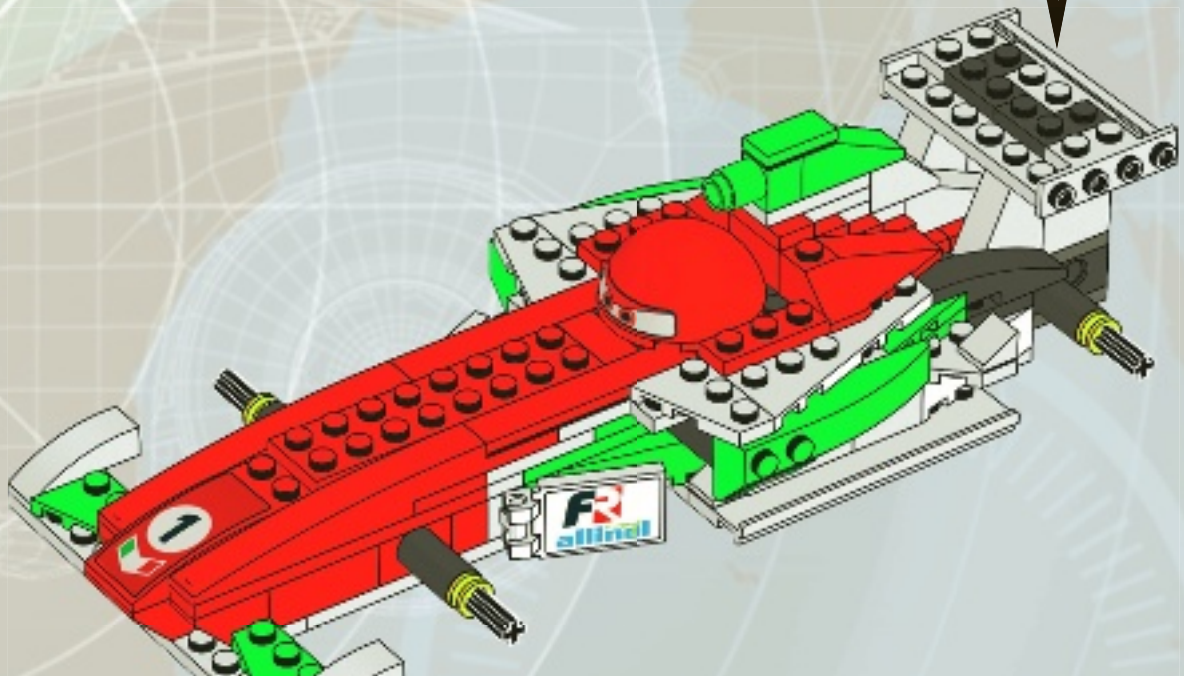
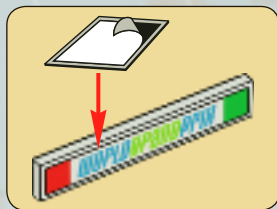

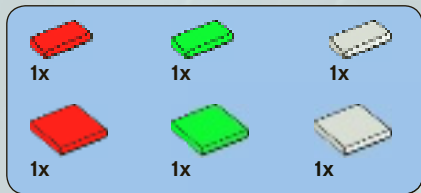

39

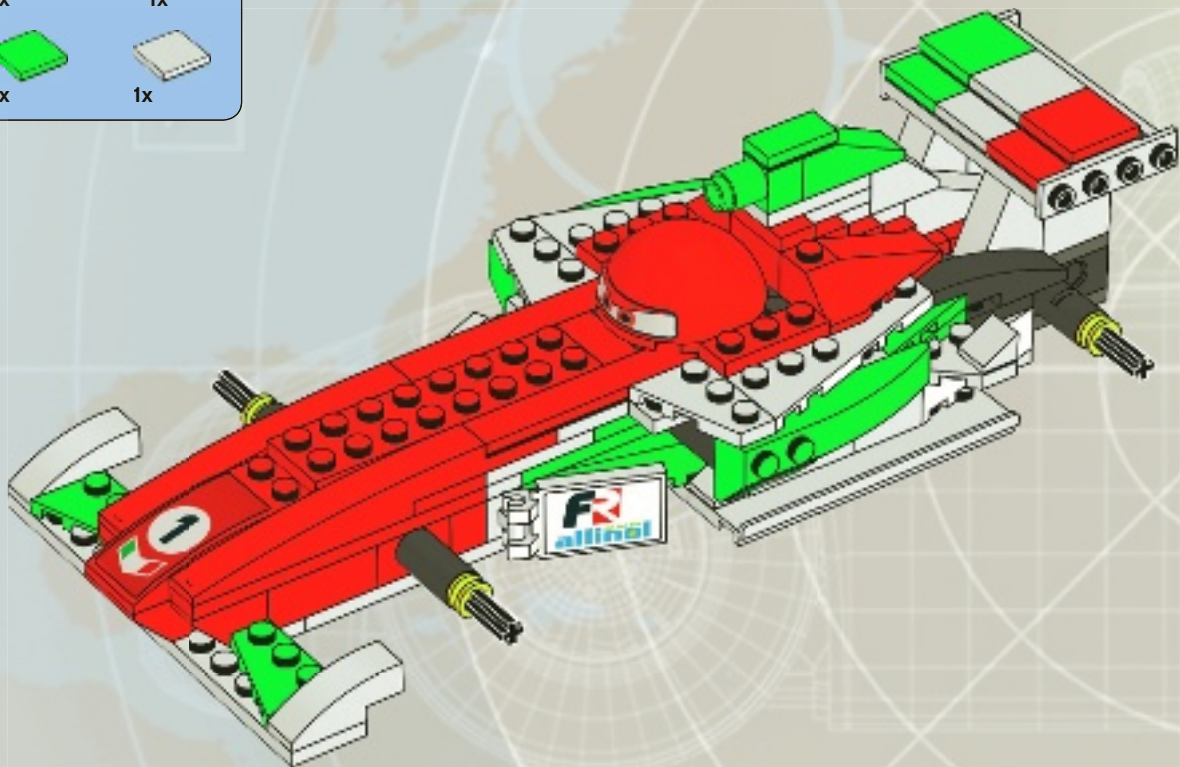



2x

40

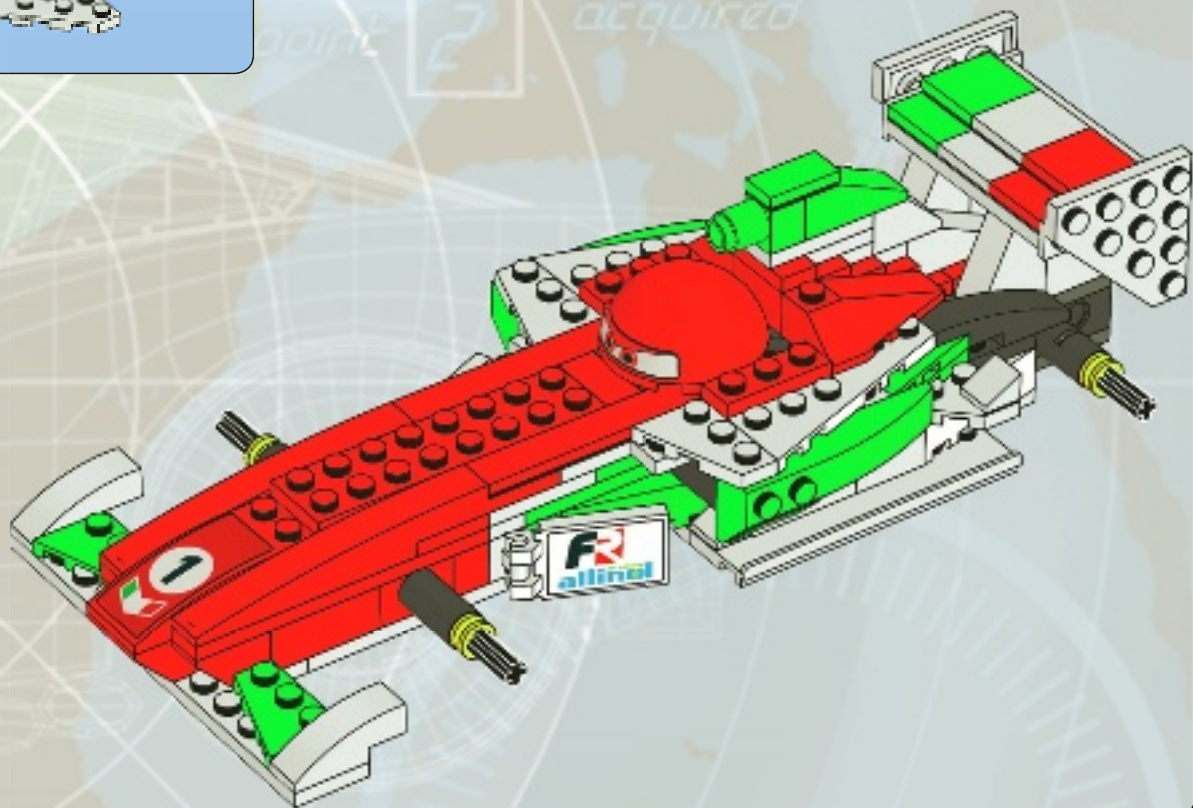

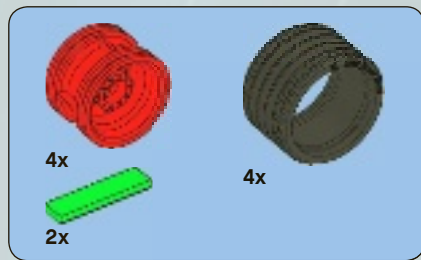

41

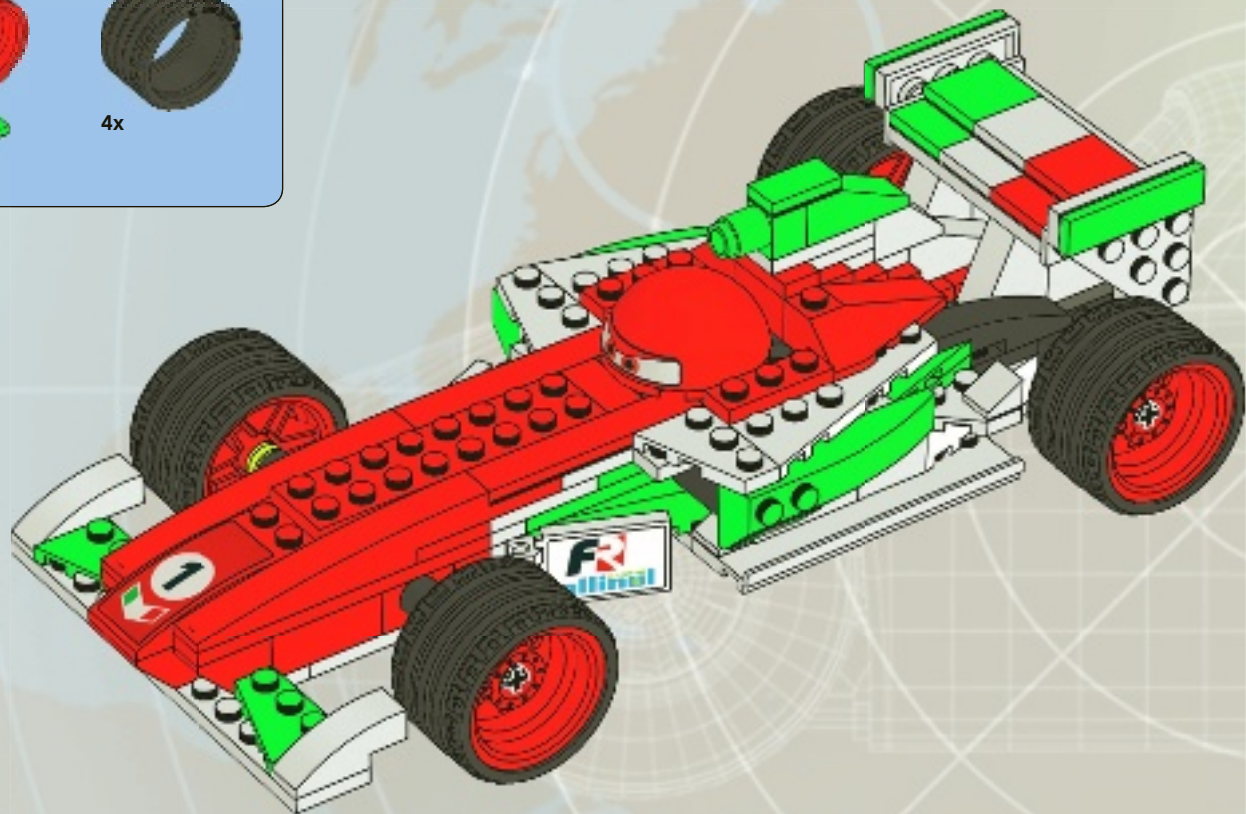



4x

42

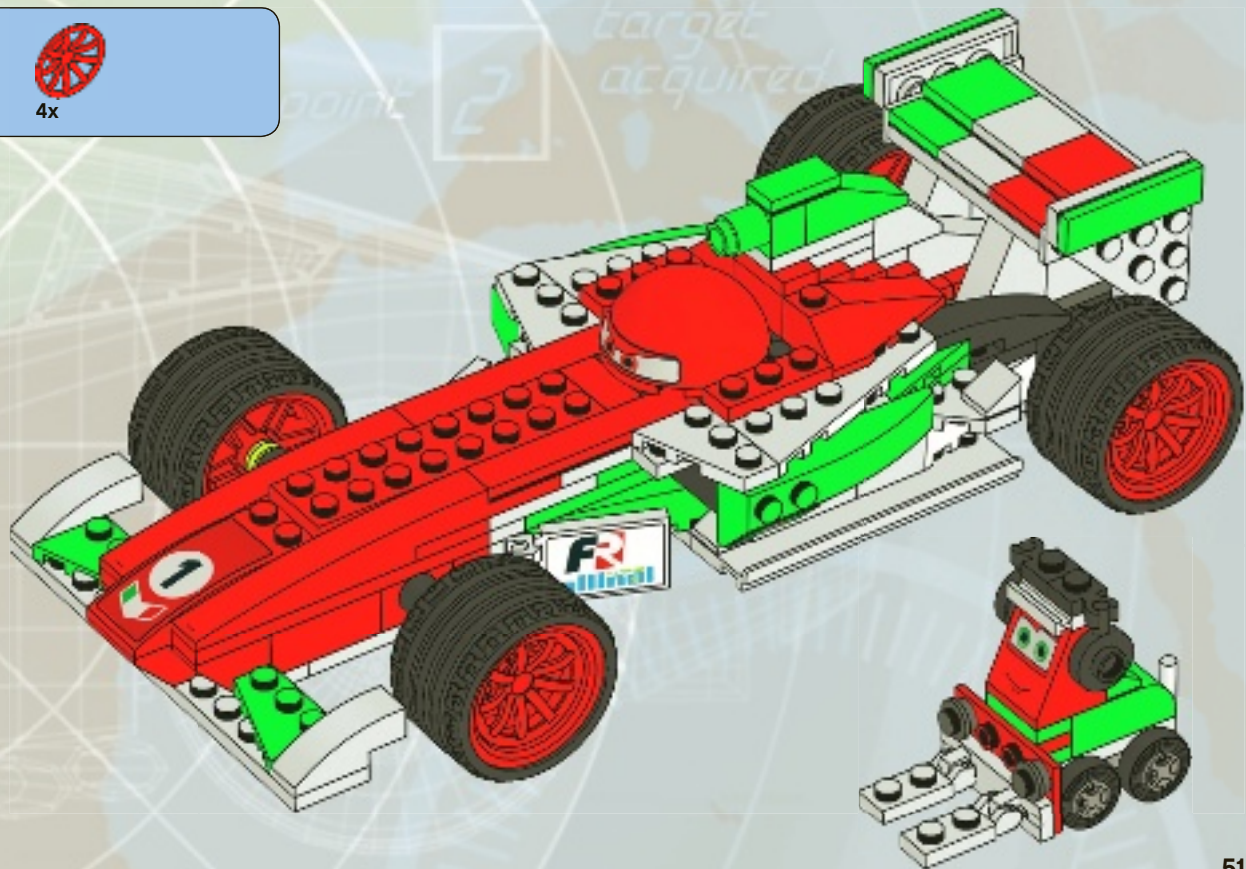



2x
4113261



2x
300301



2x
300201



2x
4119013



2x
4143254



1x
4160325



1x
4160343



4x
4504369



1x
4121932

52



2x
4515370



1x
428601



2x
4249112



2x
302401



1x
306901



2x
302301



1x
306801



3x
362301



1x
302101



2x
371001



1x
302001



2x
366601



1x
663601

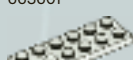

1x
379501



1x
4503008



1x
244501



1x
4528341



1x
4611700



1x
4249563



2x
4183048



3x
4282737



1x
4622572



2x
4599983

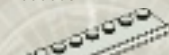

2x
4500878



4x
4160215



1x
4179874



1x
4179875



1x
4287708



1x
4287707



2x
300521



1x
300421



2x
362221



2x
370321



2x
370021



2x
366521



1x
4623073



1x
4621943



1x
4180419



1x
4180409

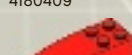

1x
4180544

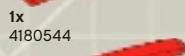

2x
4571075



2x
306921

1x
306821

2x
362321

2x
302021

2x
4113858

2x
346021

1x
303421

6x
379421

1x
4616800

1x
4622459



4x
4621948



4x
4621953



1x
4181139



1x
302124



4x
4239601

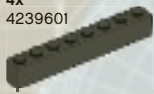

1x
300826



2x
389526



2x
370826



2x
4522034

4x
242026



1x
379526



1x
303226

2x
4550017

2x
452826



4x
4499234

4x
4516843

6x
4121715

4x
4526982



1x
4621951



1x
4621952

2x
300528

1x
306228



1x
4621941



1x
4621942



1x
4107637

1x
4522678



1x
621528

2x
306928

4x
302328

1x
4107762

2x
243128



1x
302028



1x
4243821



3x
4621946

2x
4546705



3x
4621947

3x
4211397

2x
4211504

4x
4211506

6x
4211133

2x
4210633

Customer Service

Kundenservice

Service Consommateurs

Servicio Al Consumidor

www.lego.com/service or dial



: 00800 5346 5555

: 1-800-422-5346

8484





LEGO club

FREE! GRATIS! GRATUIT!

SIGN UP ONLINE!

www.LEGOclub.com



00800 5346 5555*



1-866-534-6258 • 1-877-518-5346

US & Canada only

Outside only

- * Freephone. Mobile charges may apply.
- * Numéro sans frais. Des frais peuvent s'appliquer avec les téléphones cellulaires.
- * Gebührenfrei, Kosten für Anrufe aus Mobilfunknetzen können abweichen.
- * Gratis telefonnummer vanaf vaste lijn.
- * Det er et gratis nummer, når du ringer fra fasttelefon.
- * Det är gratis, när du ringer från en fast telefon.
- * Numéro sans frais. Des frais peuvent s'appliquer avec les téléphones portables.



WIN!

Go to www.LEGOsurvey.com/product to fill out a survey for a chance to win a cool LEGO® Product.

No purchase necessary.

Open to all residents where not prohibited.



www.LEGOsurvey.com/product

GEWINNE!

Nimm an der Umfrage auf www.LEGOsurvey.com/product teil und hab die Chance ein cooles LEGO® Produkt zu gewinnen!

Die Teilnahme am Gewinnspiel führt zu keinerlei Kaufverpflichtungen. Teilnahme in allen nicht ausgeschlossenen Ländern möglich.

WIN!

Ga naar www.LEGOsurvey.com/product, vul een enquêteformulier in en maak kans op een cool LEGO® product.

Geen aankoopverplichting, iedereen mag deelnemen, uitgezonderd ingezetenden van landen waar een enquêteverbod geldt.

GAGNE!

Visite www.LEGOsurvey.com/product pour répondre à un questionnaire et avoir une chance de gagner un produit LEGO® très cool!

Aucune obligation d'achat. Ouvert à tous les résidents des pays autorisés.

当てよう!

www.LEGOsurvey.com/product にアクセスして、アンケートにご記入ください。当選者にはレゴ®製品を差し上げます。

お買い上げの必要はありません。

禁止されていない限り、すべての皆様にご利用いただけます。