

# BIONICLE

[www.bionicle.com](http://www.bionicle.com)



8-16

10203

SPECIAL 3 IN 1  
VOPORAK



# www.bionicle.com

**BIONICLE The Official Web Site**  
http://www.bionicle.com

LEGO BIONICLE TOYS PRODUCTS CLUB SHOP LEGOLABS

**BIONICLE** Karaka club Enter code here!

Home | Bionicle | Bionicle | Products | Expeditions | Wall of History

## The Great Rescue

**That Story**

The Toa Nui were recruited by Metru Nui to save the Bionicles, who still lie sleeping in caverns beneath the Coliseum. But the city of Aganor has become a city of shadows, enveloped by sinister forces known as the Visorak. Commanded by their new Toa, the Toa Matoro have bionicle'd into half-Ark, half-Batoid Toa.

**NEW DOWNLOADS**

Visit our BIONICLE website for more information about BIONICLE: Matoro Nui, Metru Nui or Matoro's quest for the Mask of Life.

Click here for the BIONICLE DVD-ROM: BIONICLE: MATORO NUI, PART 1 of the LEGO Three! [Download](#)

**POWER RANGERS COLLAB**

Green | Orange | Yellow | Purple | Black | Red

© 2014 The LEGO Group. All rights reserved. LEGO and the LEGO logo are registered trademarks of The LEGO Group.

Customer Service | About Us | Educators | Site Index

Privacy | Legal Notice

This collage displays various views of the BIONICLE website, including:

- Product detail pages for different Bionicle characters and sets.
- A map of the Bionicle universe.
- A gallery of character images.
- Navigation menus and site structure.

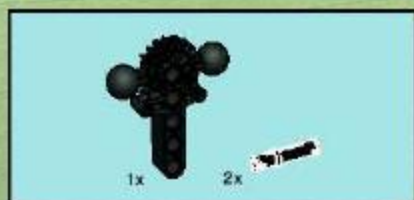
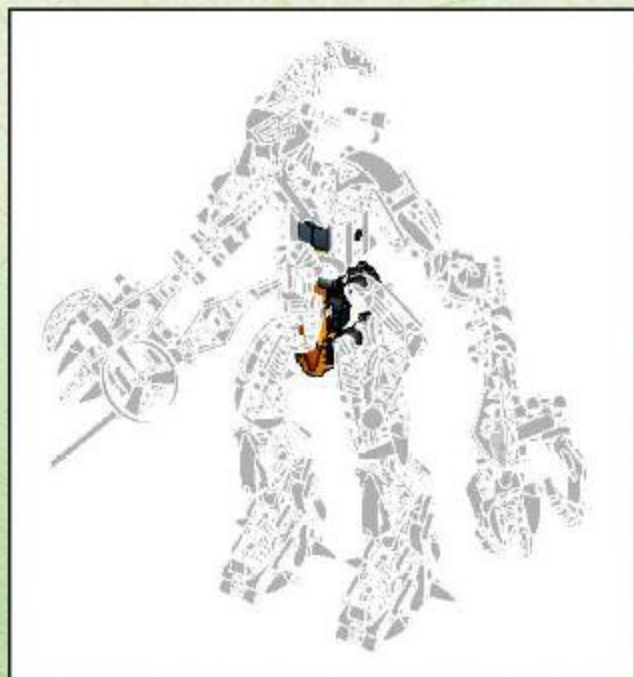

1



2





3



4

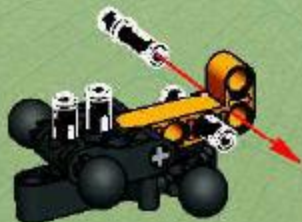

5



6

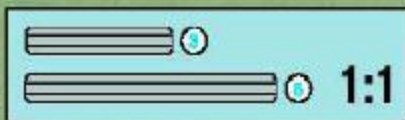



1x

7



1x



1x



1x



8

1



2



2x

9



1x

10



1:1



1

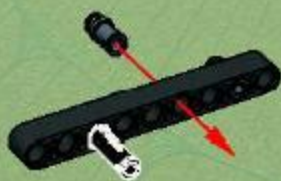

2





3

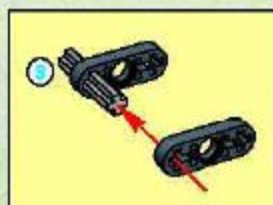

4

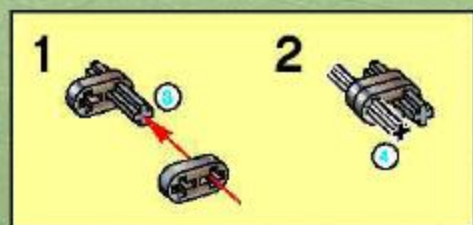



5

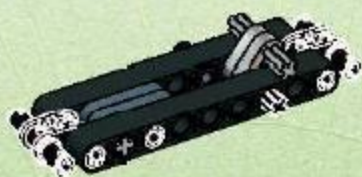

6

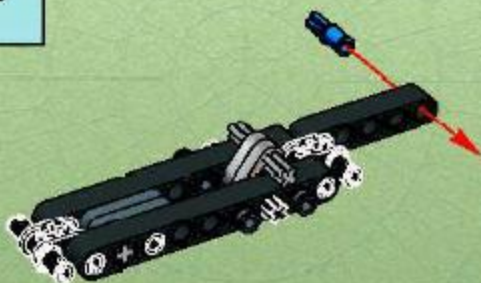

7

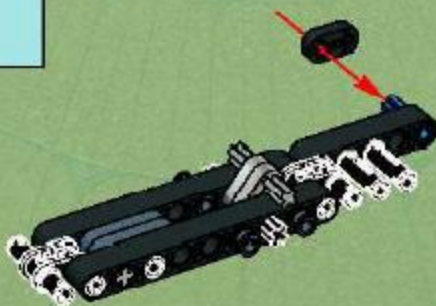





8

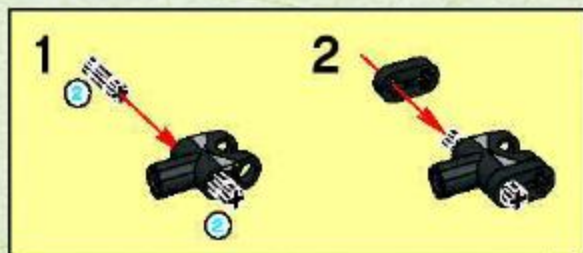

9



10





11



12

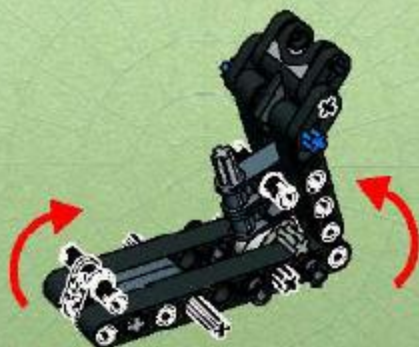

13





# 14

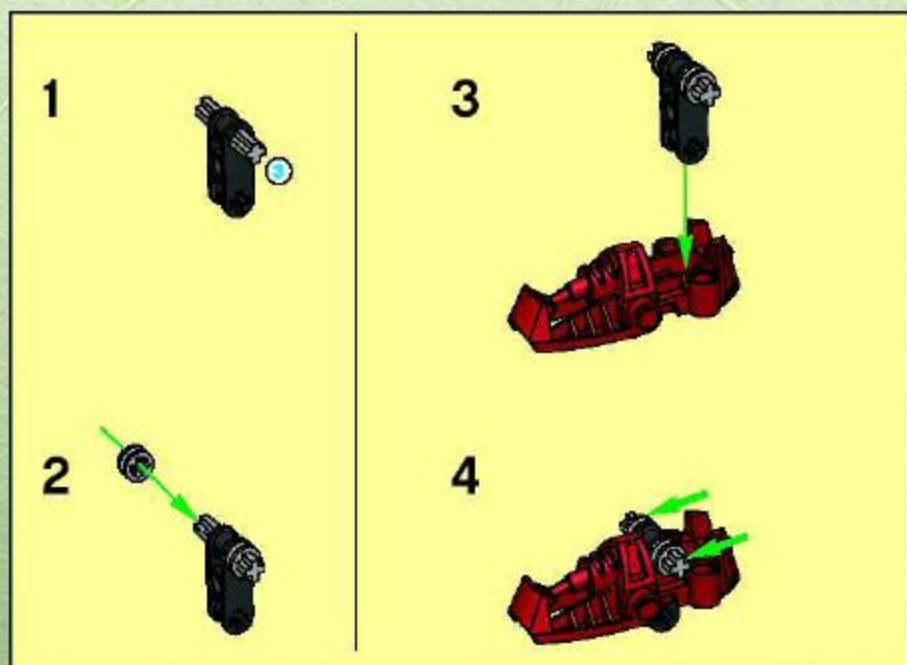



15

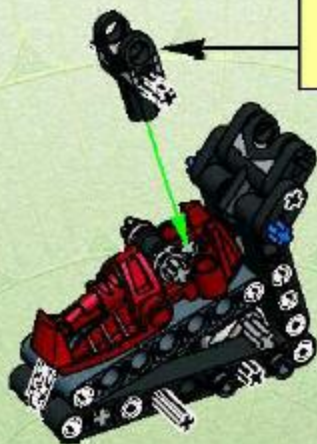
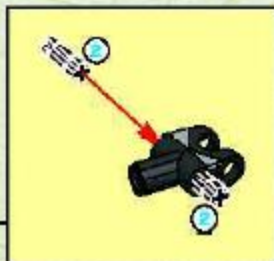

16





1x



2x

# 17



2x



1x



1x



# 18



1:1

# 19

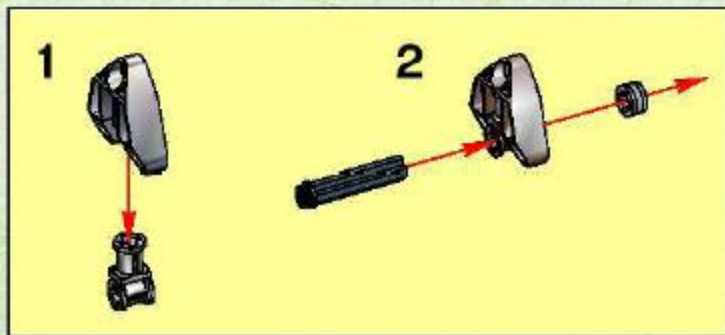

# 20



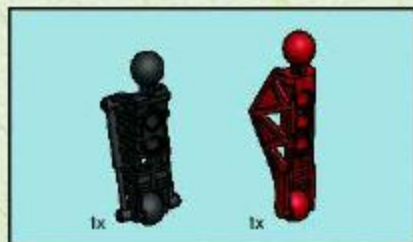

21



22

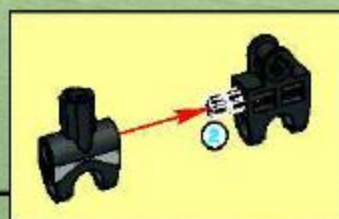

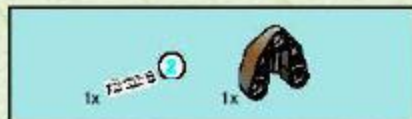

# 23

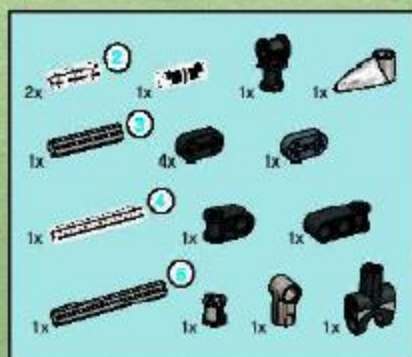

# 24

1

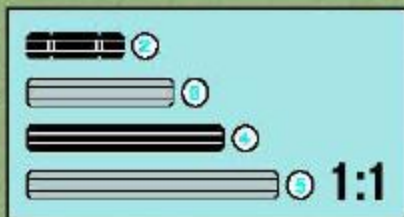



2



5



3

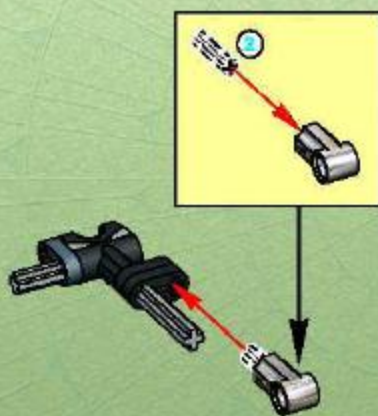

6

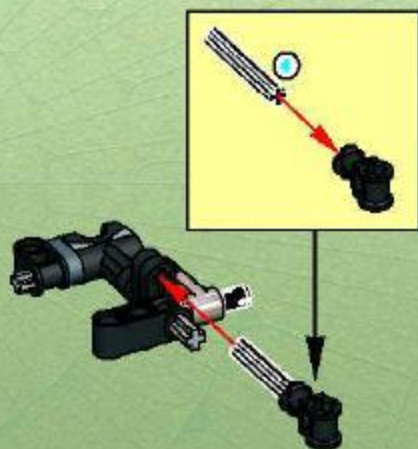

4

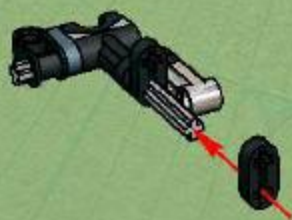

7



8

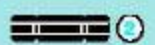

1:1

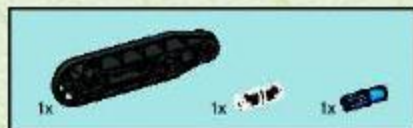

25





# 26

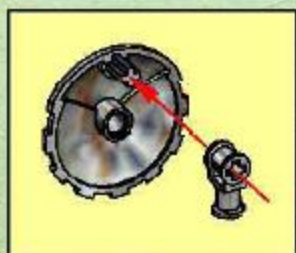



# 27

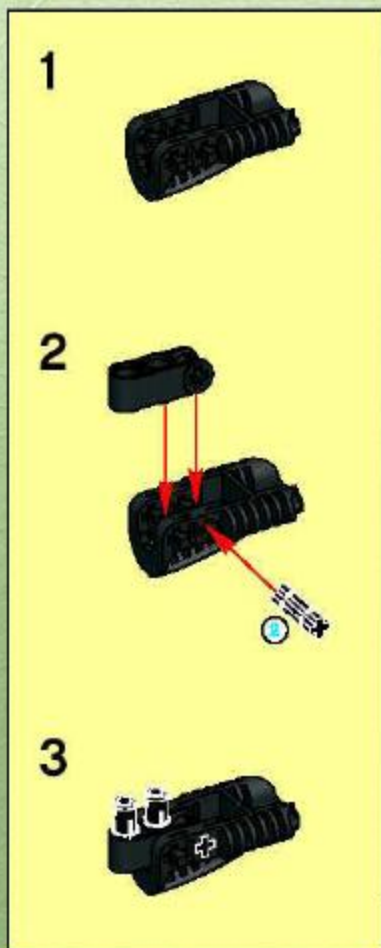

28



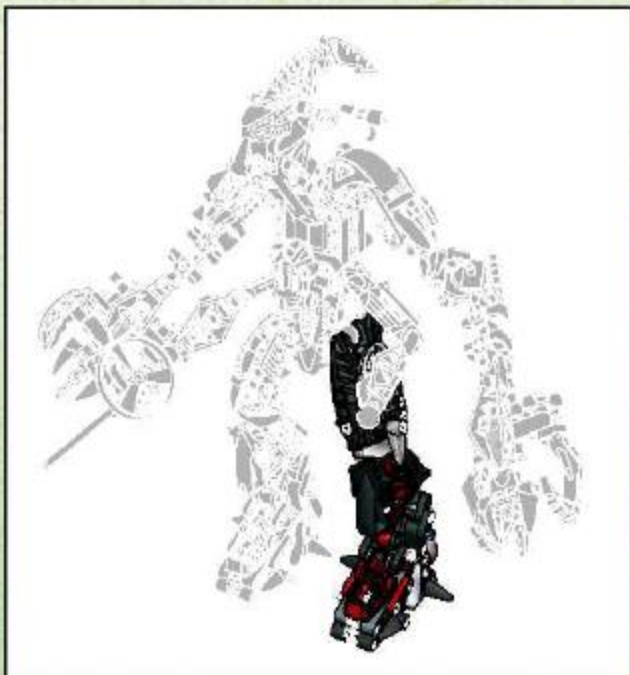

1

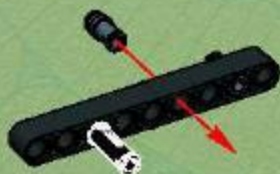

2





3

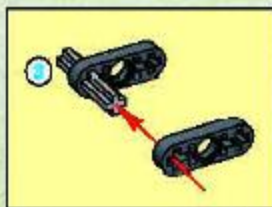

4

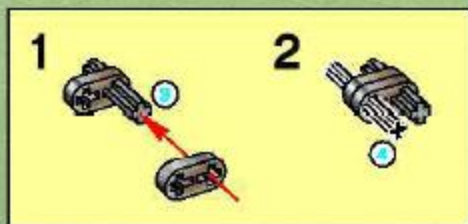





5

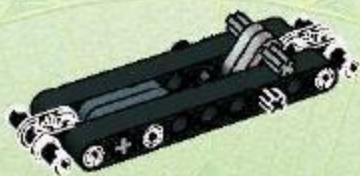

6

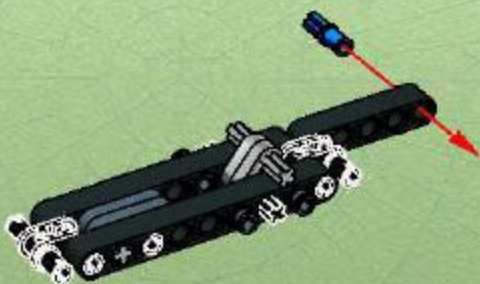

7

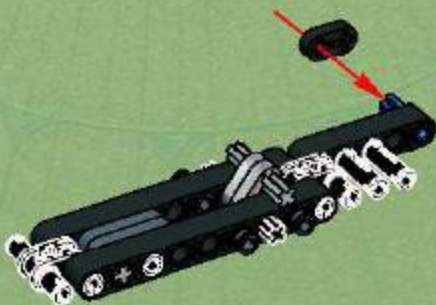



8

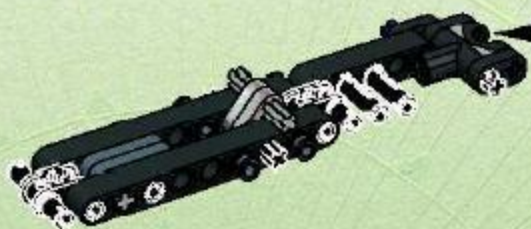
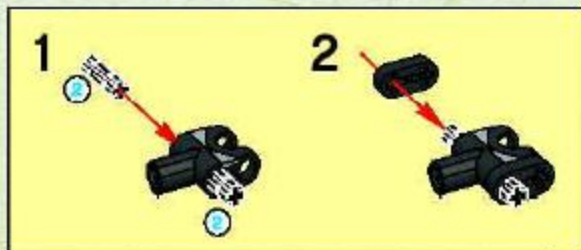

9



10





11

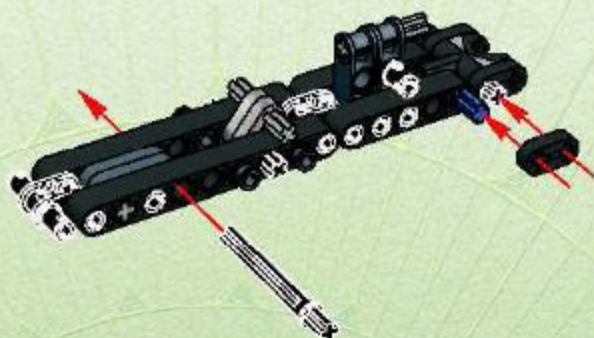

12



13





14

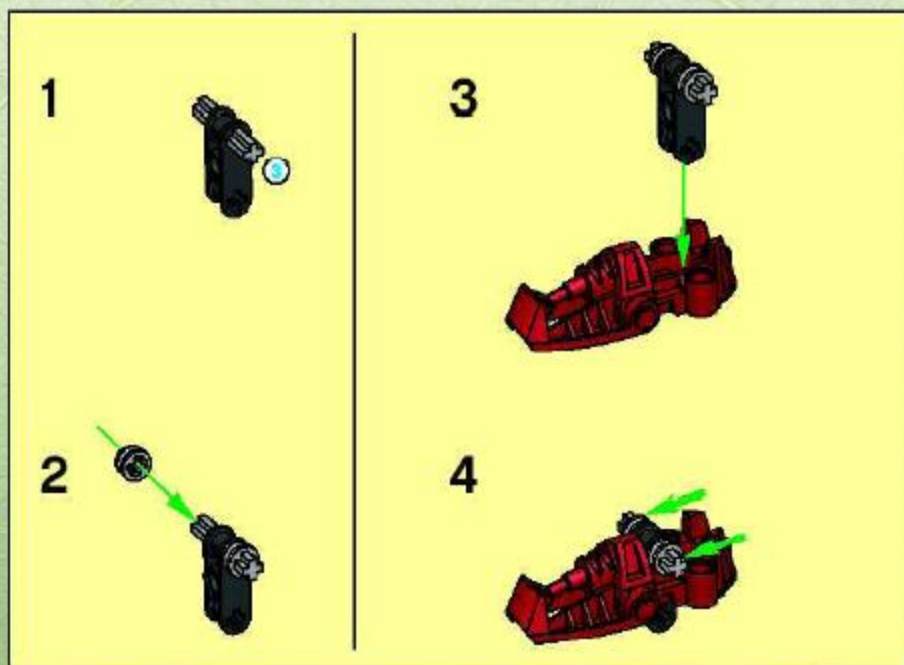



15

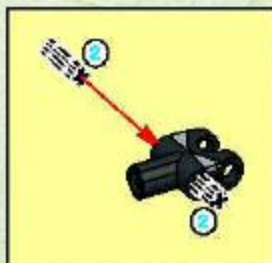

16





17



18





19

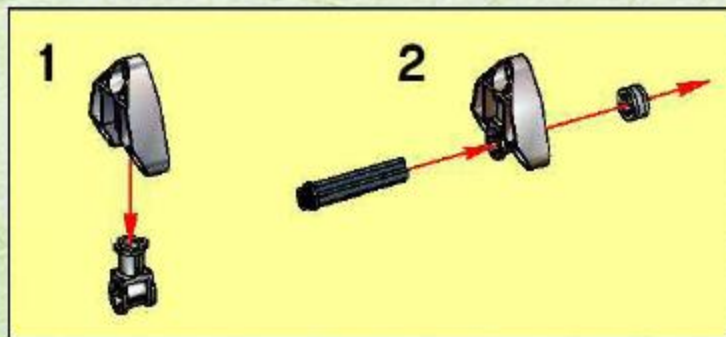

20





21



22

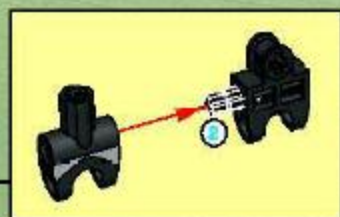





23

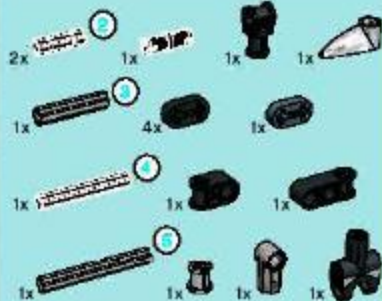

24

1

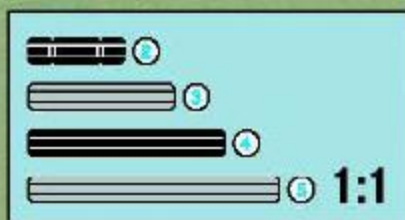

2



3

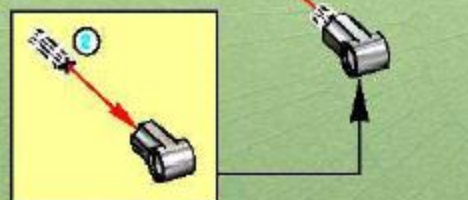

4



5



6

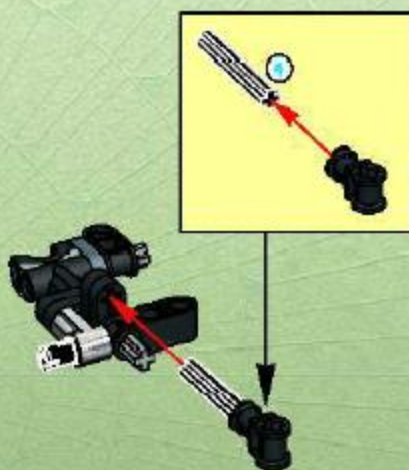

7



8





25





26

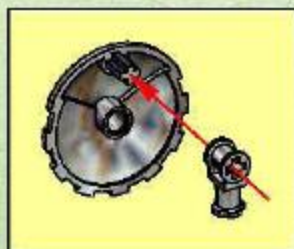



# 27

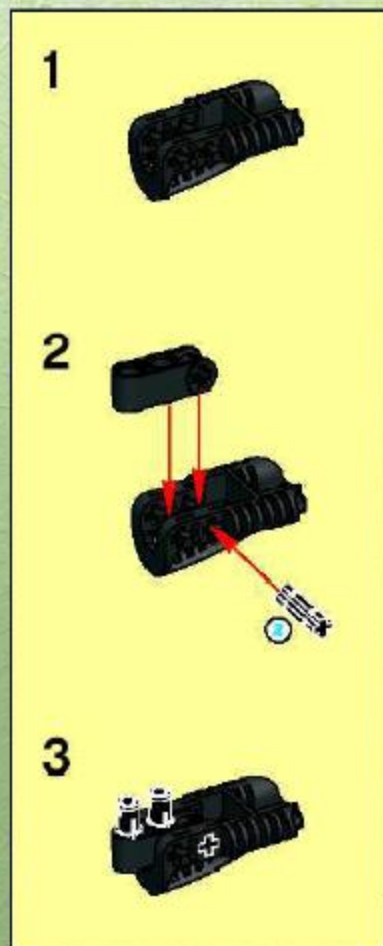

28



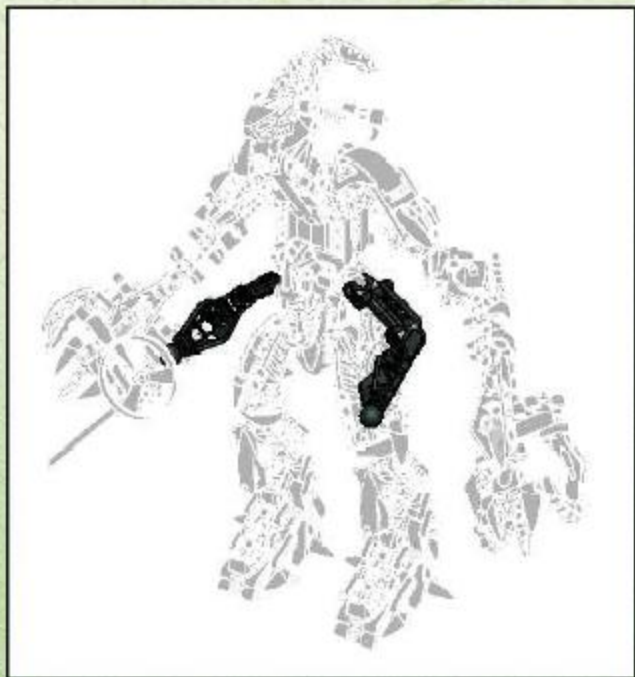

1

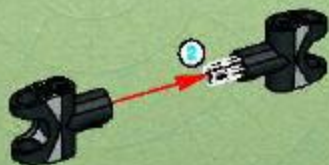

2

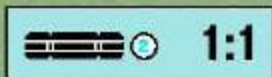





3

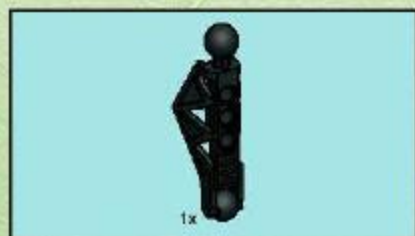

4



2x

5

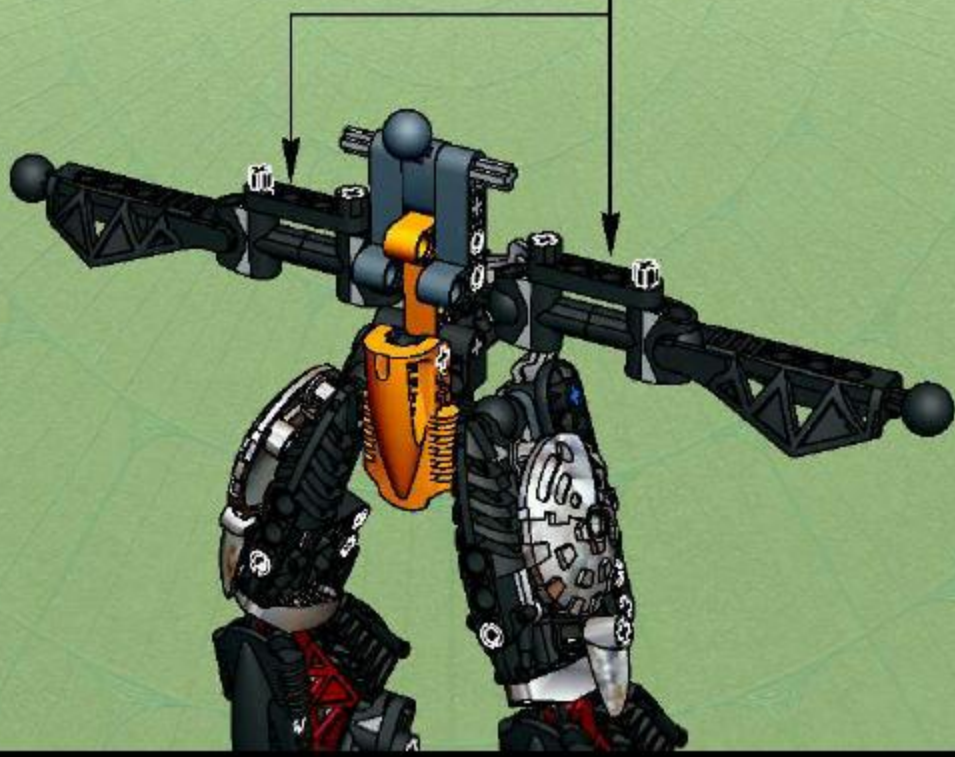



1



2

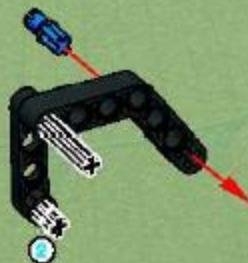



3



4

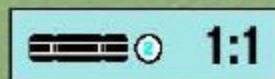
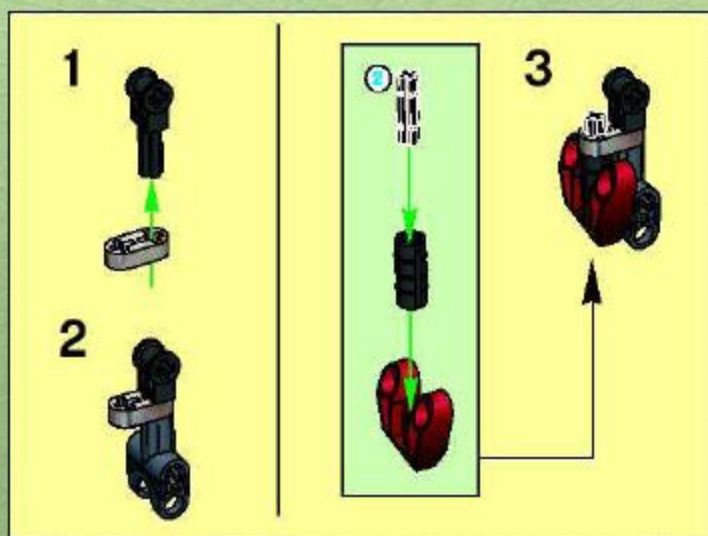



5

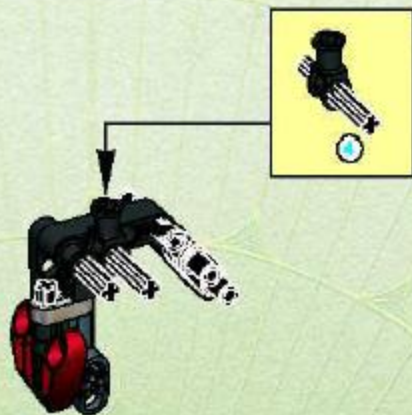

6



7

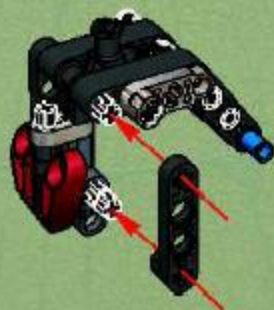



1x

8



9

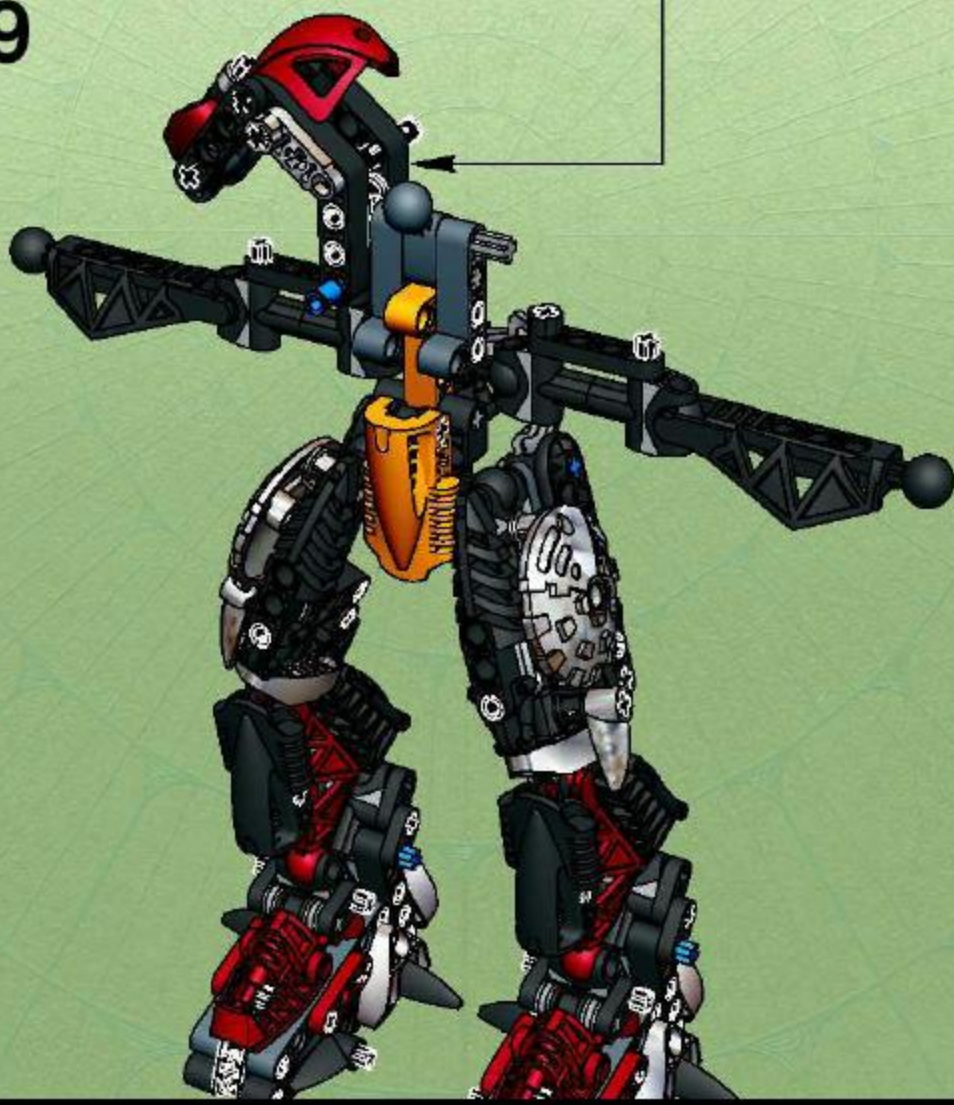



1



2





3

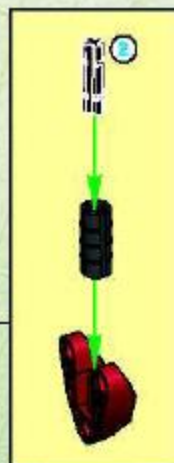

4



5

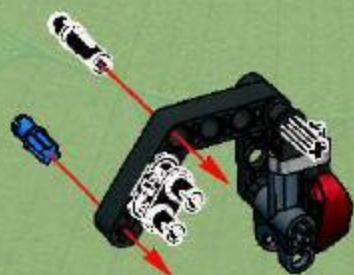



6

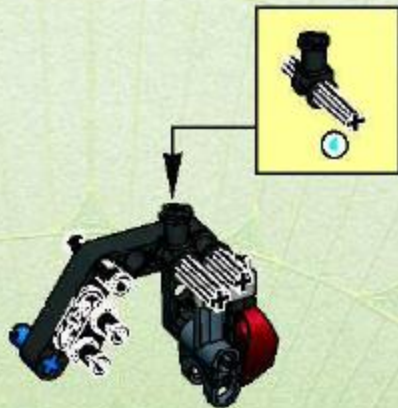

7



8

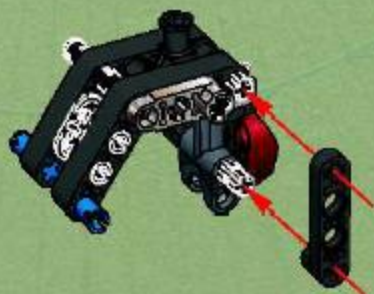





1x

9



10





10

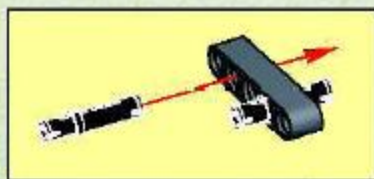



11

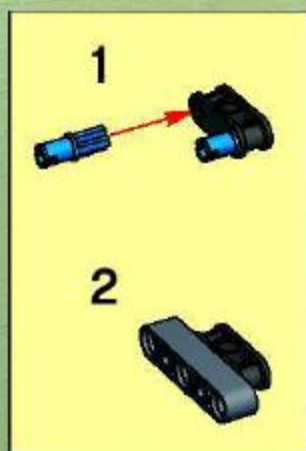
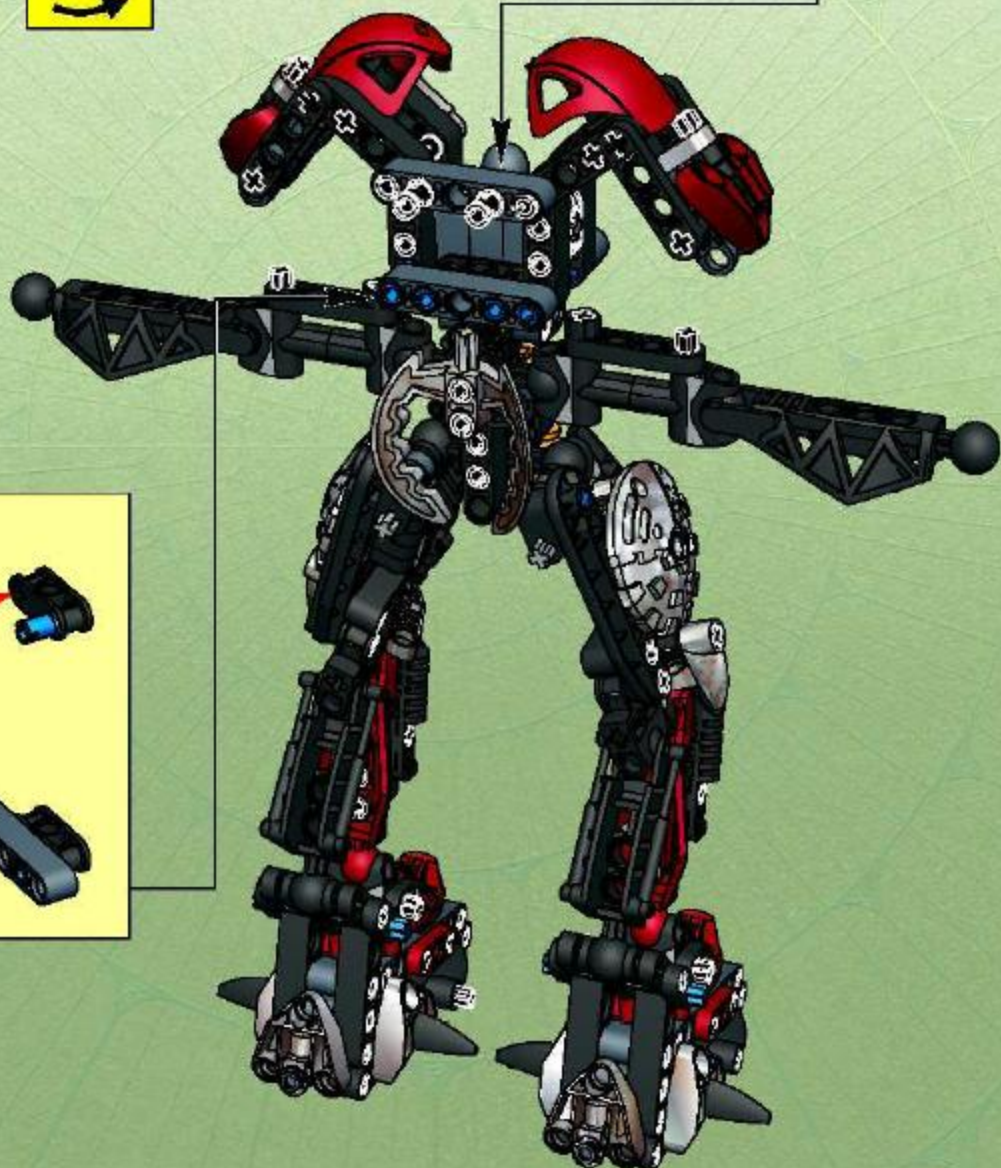
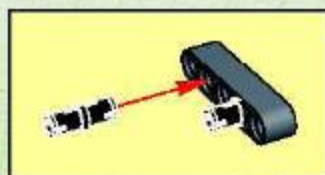



12





1



2

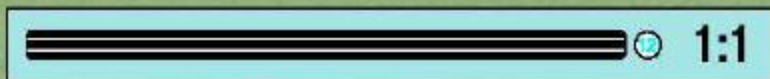

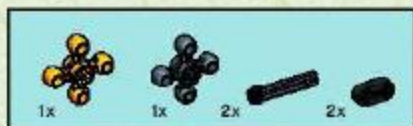

3



4



5

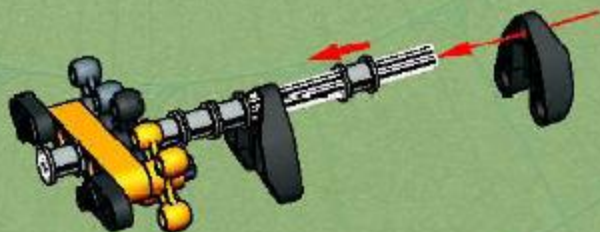



6

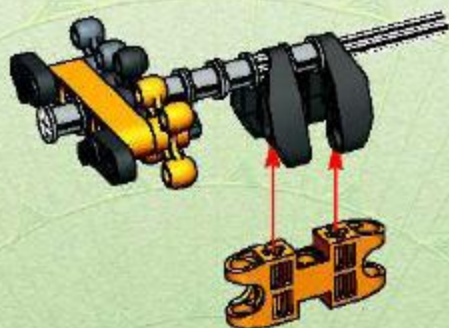

7

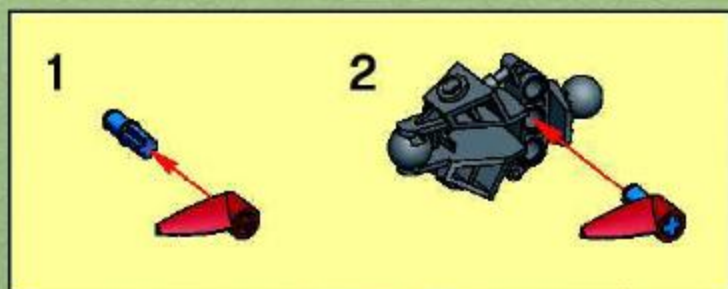

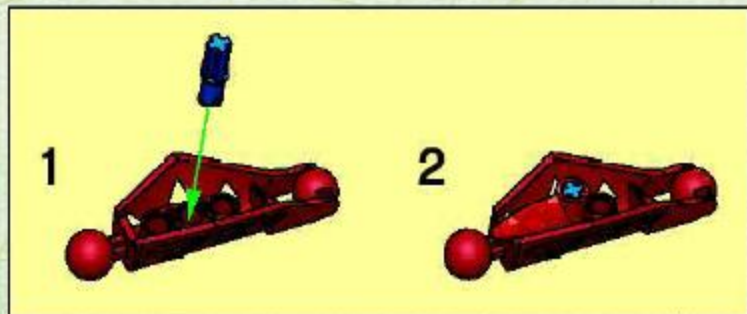

8



9







2x

10



11

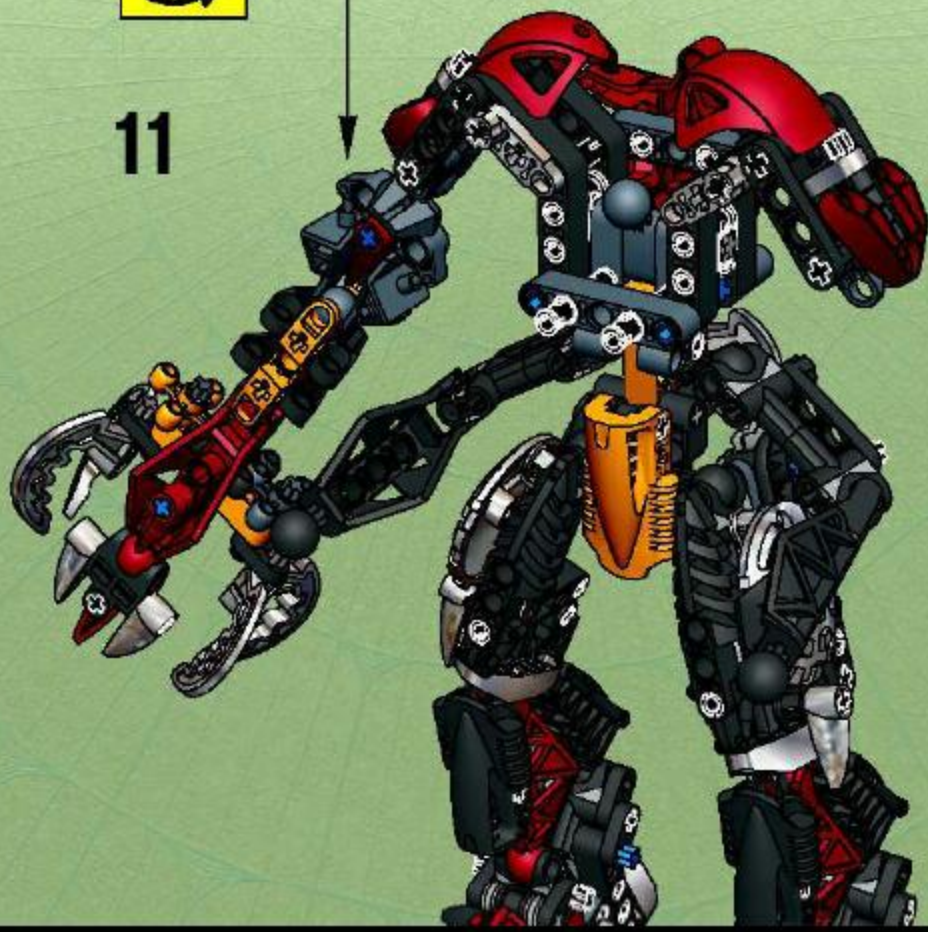



1



2



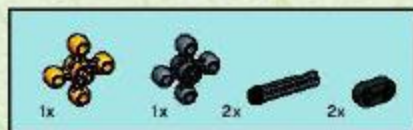

3



4



5





6

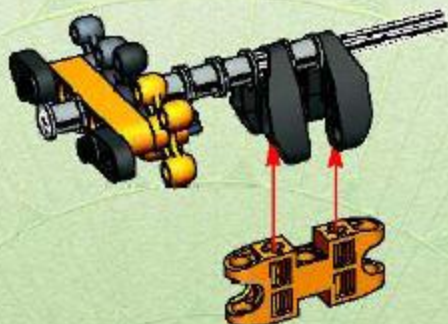

7

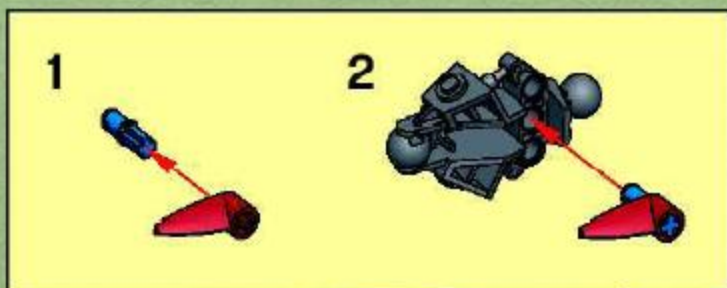

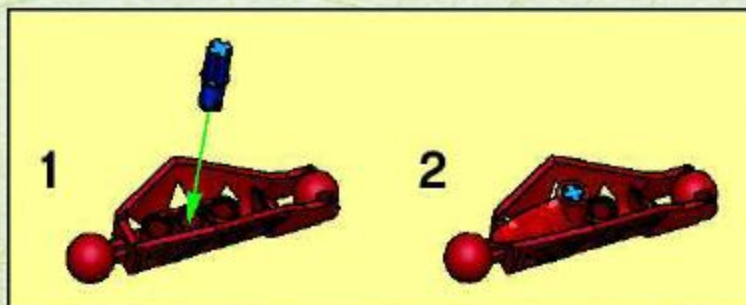

8

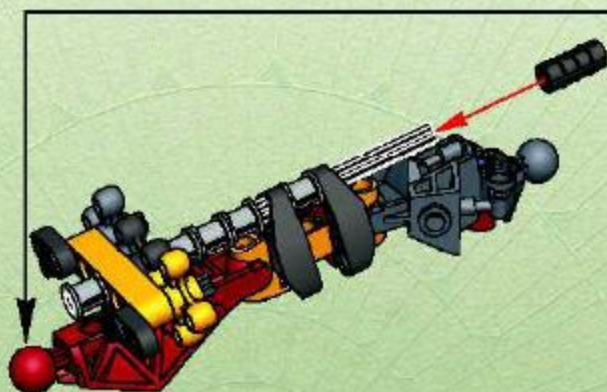

9

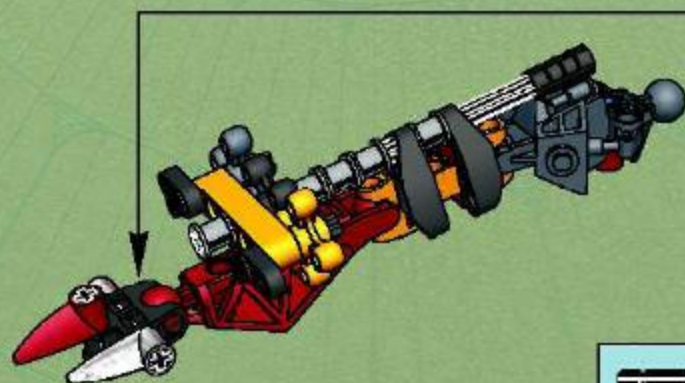



2x

10



11

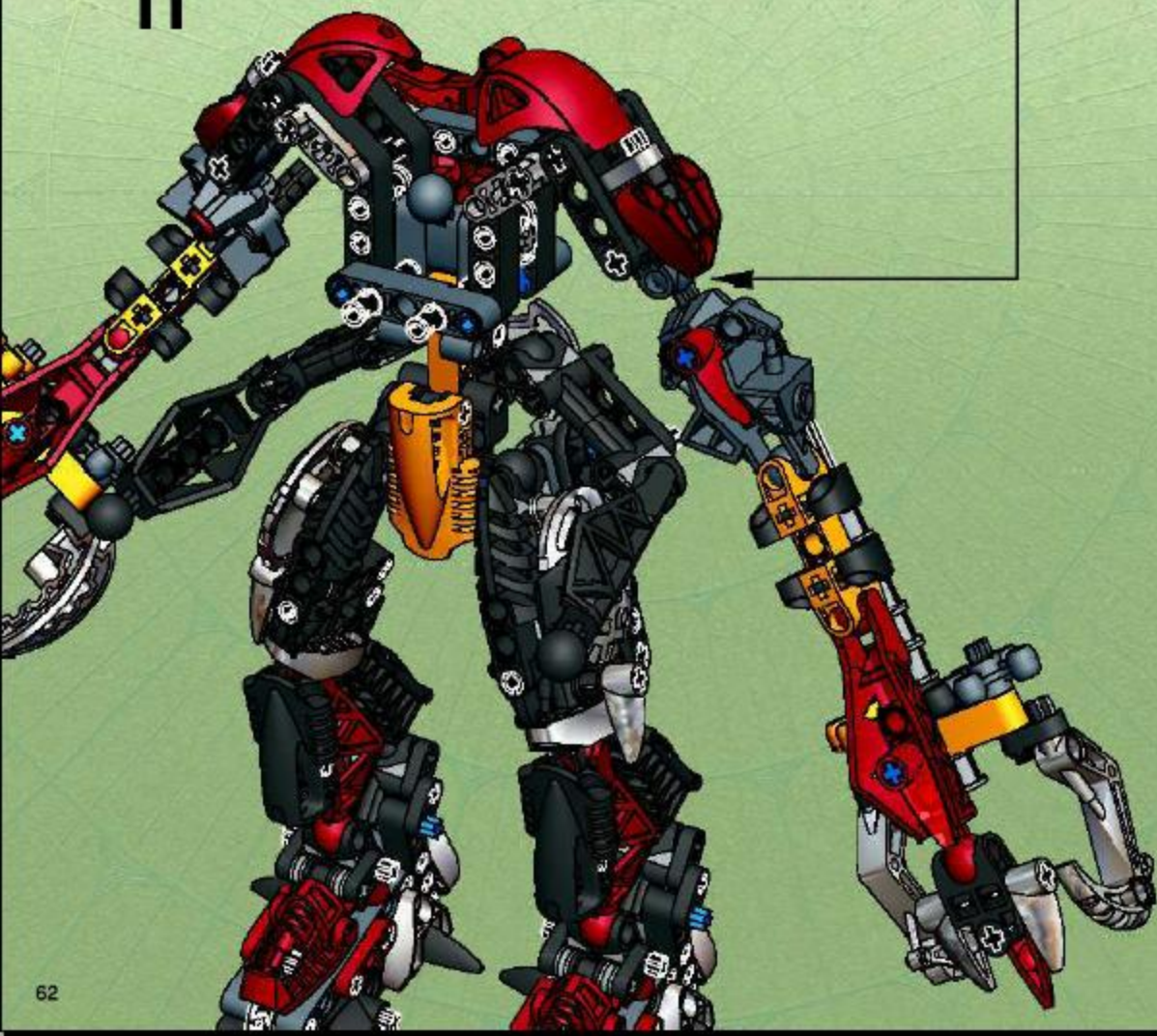

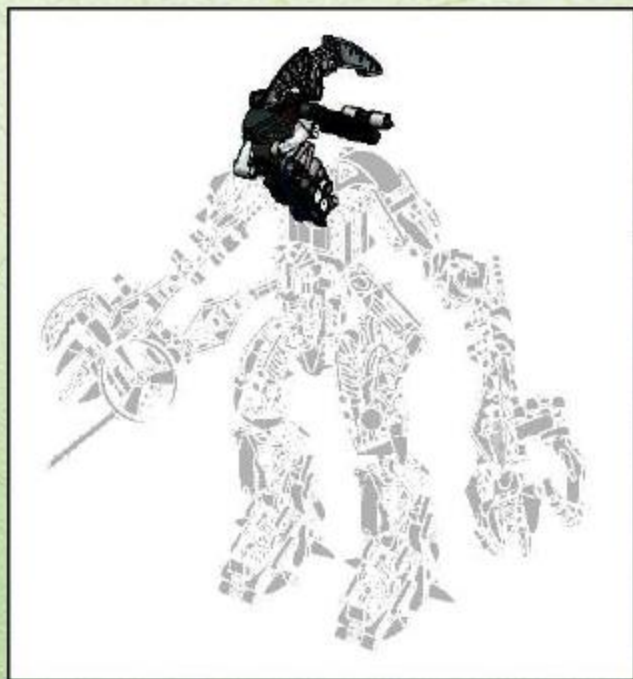

1

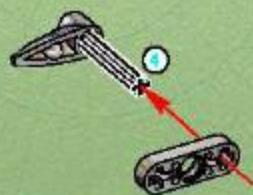

2





3



4



5







6

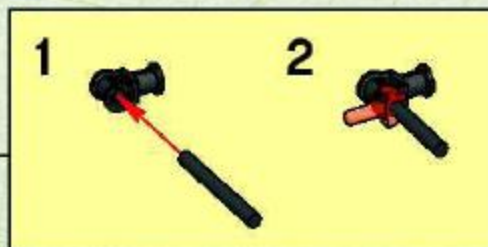

7



8





8

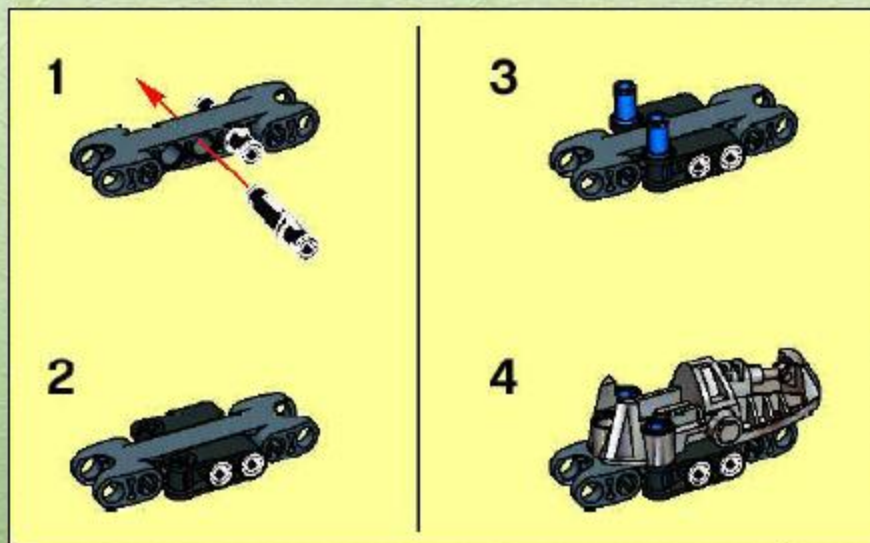

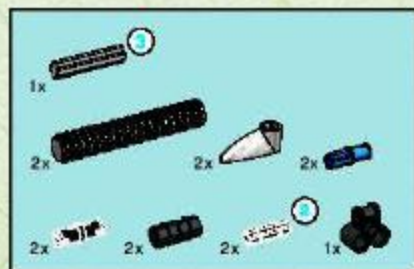

9

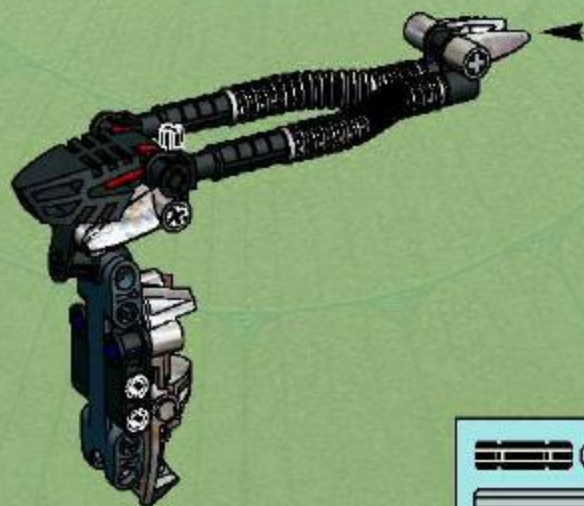
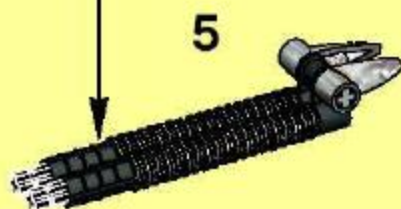
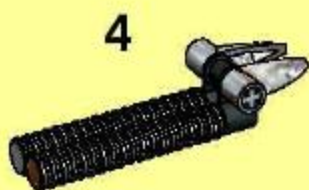
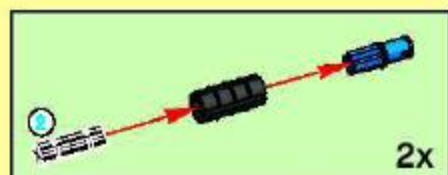
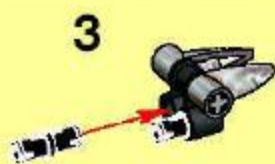
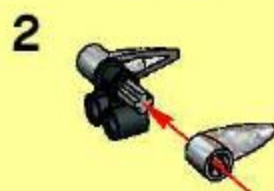

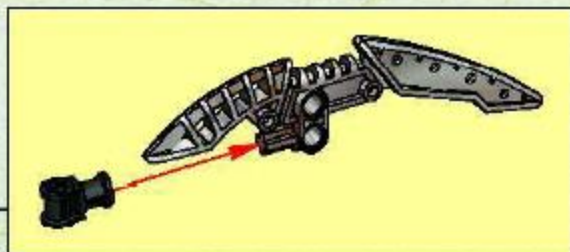
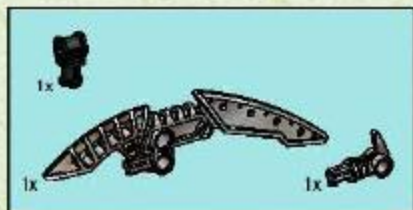

10



11

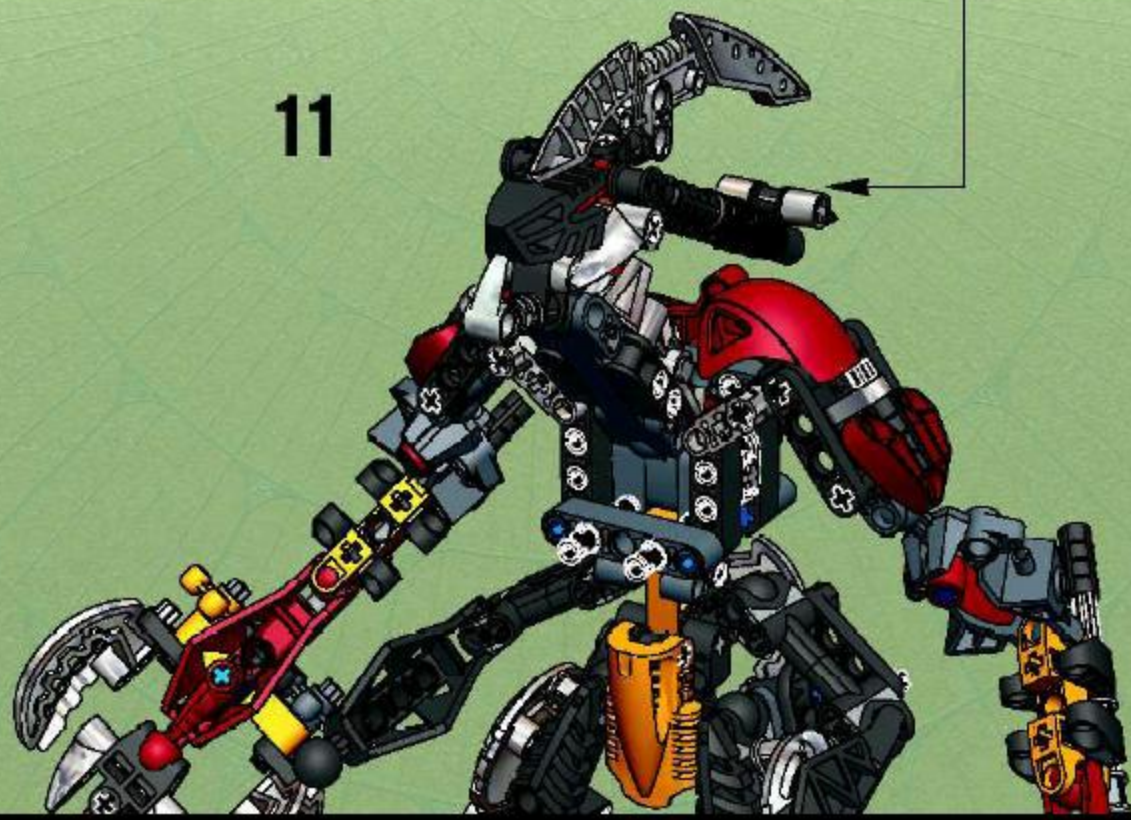

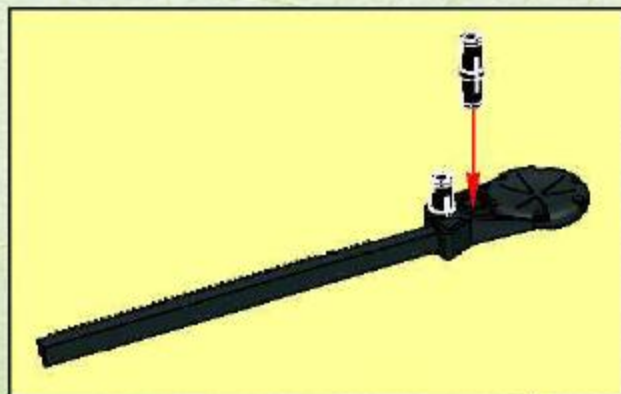
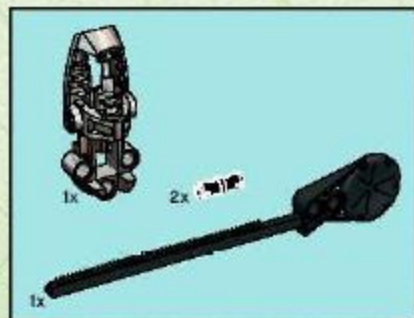

12

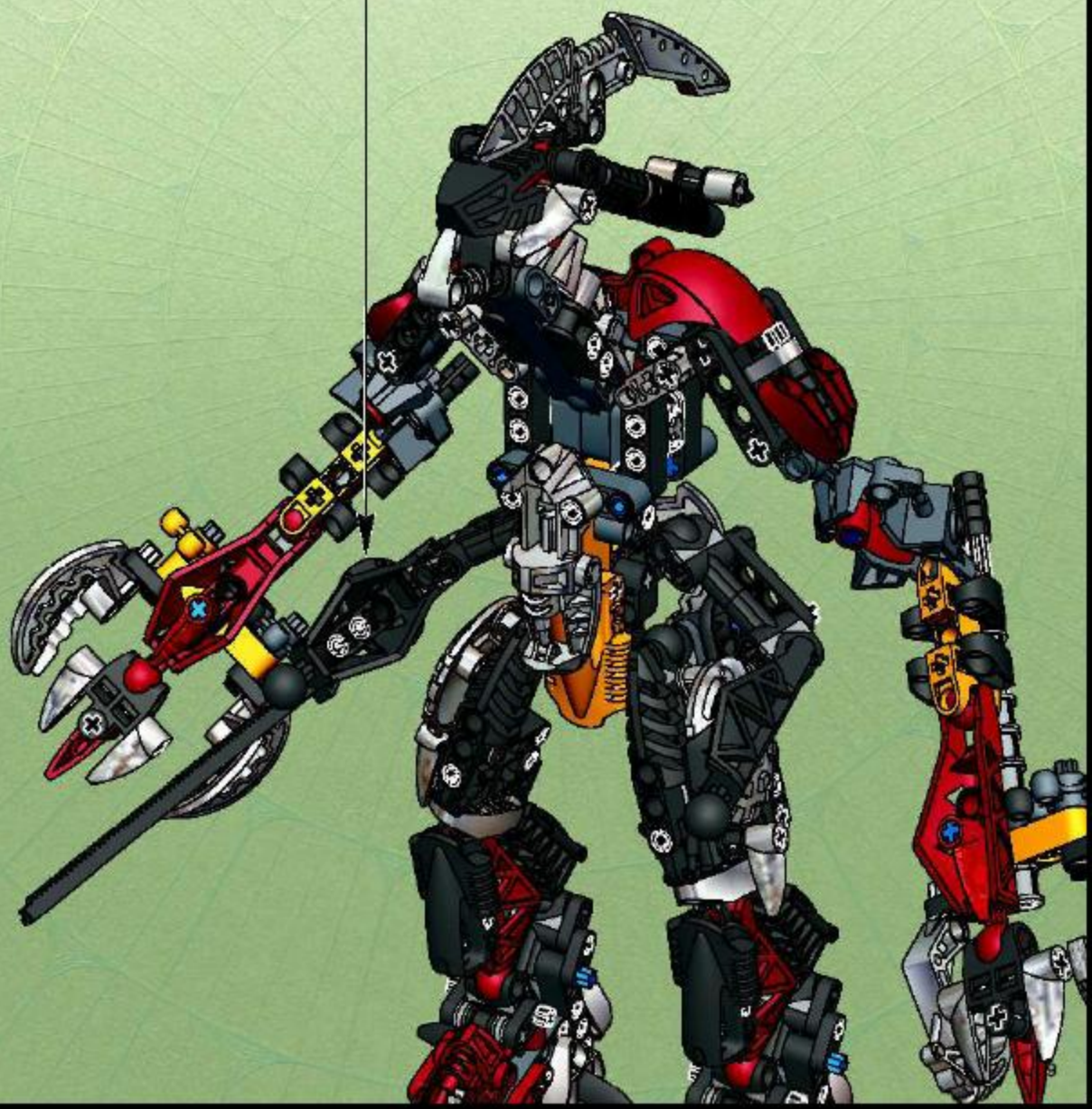



# 13

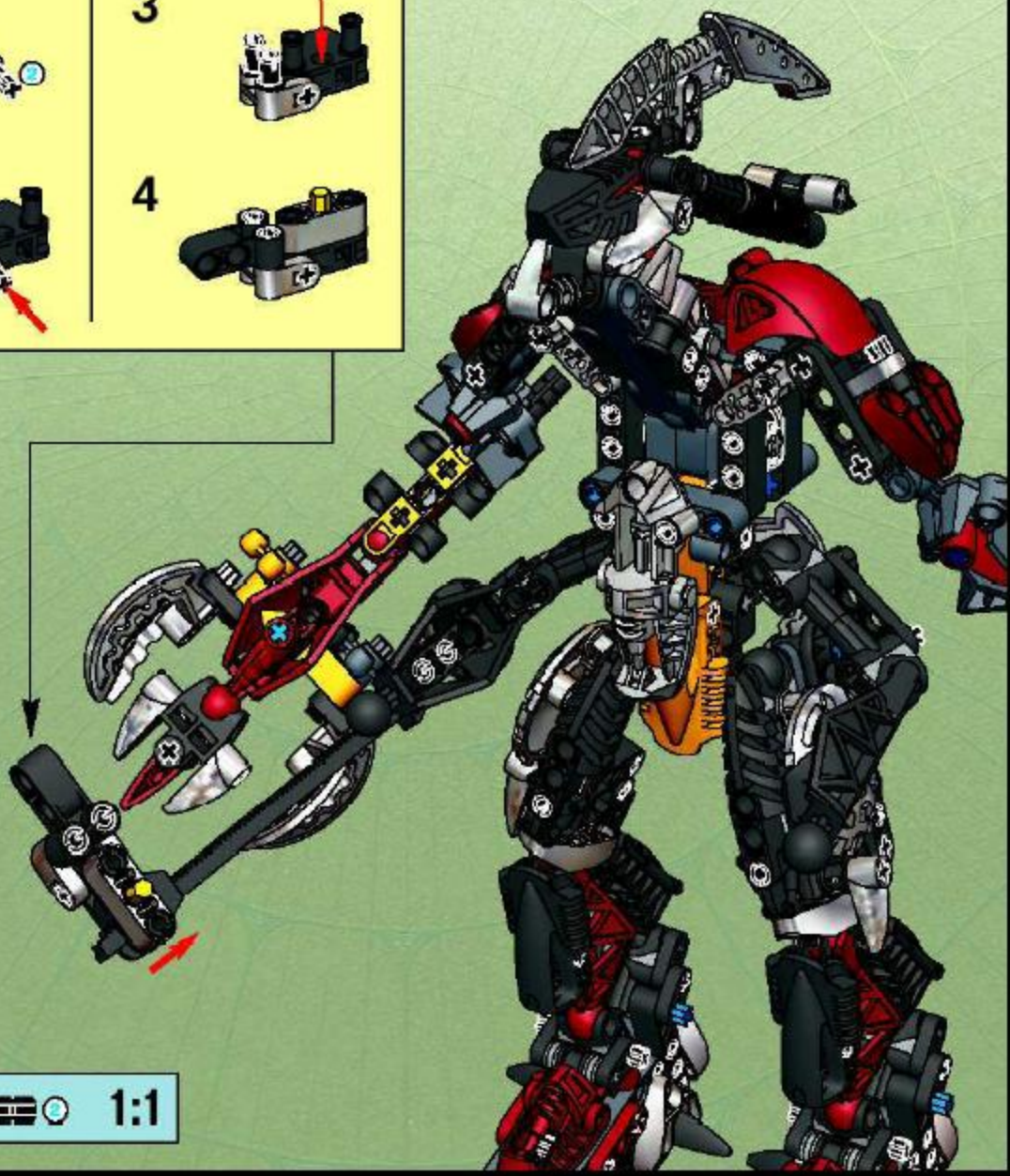
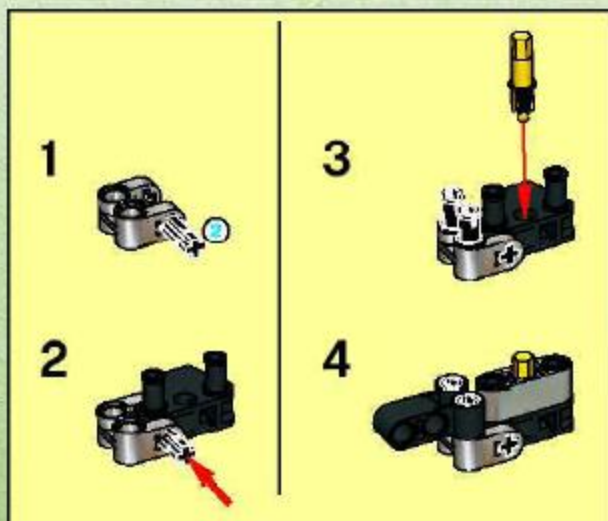



1x

14



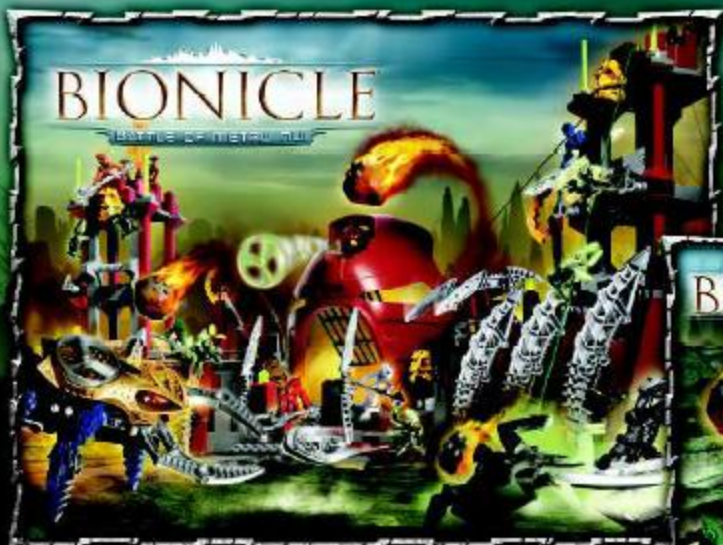

8759



8757

## TOA HORDIKA



VAKAMA  
8738



NOKAMA  
8737



WHENUA  
8738



ONEWA  
8738



MATALI  
8740



NUJU  
8741



VOHTARAK  
8742



OOHORAK  
8744



ROPDRAK  
8745



KEELERAK  
8746

SUKORAK  
8747

BOGARAK  
8745



# BIONICLE®

TOWER OF TOA

TOA HORDIKA



VAKAMA



NOKAMA



POHATU



KOPAKA



WHENUA



TURO



# Discover the LEGO® UNIVERSE!



www.LEGOuniverse.com



**LEGO** SHOP at HOME

The World's Biggest  
LEGO Shop!

English

Deutsch

Français



LEGO SHOP at HOME

Shopping Cart  
\$100.00

Building Sets Departments

- Waka & Cruise
- GLINTO™

BASIC INFO

- Home & Contact
- CLUB™
- Gifts
- Shipping & Returns
- SHOP FAVORITES
- Sales & Deals

**LEGO** club

LEGO club

LEGO Club

LEGO Club

LEGO Club

LEGO Club

LEGO Club

LEGO club

LEGO club

LEGO club

# Win! Gagne! Gewinne! 当たります



## WIN LEGO® PRODUCTS

We would like to know what you think about our new LEGO® product. If you could help us by answering a few questions you are in with a chance of winning an exciting LEGO prize. It will only take you about 3 minutes! Log on to the web address below for further instructions.

We would really like to hear what you think about your new LEGO product. If you'd like to help us, go to the web address below for further instructions.



## GAGNE DES PRODUITS LEGO®

Nous aimerions savoir ce que tu penses de ton nouveau produit LEGO®. Si tu veux bien nous aider en répondant à quelques questions, tu recevras peut-être bientôt un fantastique prix LEGO®. Et cela ne te prendra que 3 minutes environ! Tu obtiendras davantage d'informations en visitant le site Internet indiqué ci-dessous.

Nous aimerions savoir ce que tu penses de ton nouveau produit LEGO. Si tu souhaites nous aider, rends-toi à l'adresse Internet ci-dessous où tu trouveras des instructions supplémentaires.



## Kedves Új LEGO® Vásárló

Ha elégetgetsz a [www.acnielsen.aim.dk/lego](http://www.acnielsen.aim.dk/lego) honlapra és ott angol, francia, német vagy japán nyelven megválaszolsz néhány kérdést, akkor részt veszel egy versenyben, amelyben értékes LEGO® díjakat nyerhetsz.



## GEWINNE LEGO® PRODUKTE

Wir sind sehr an deiner Meinung über dein neues LEGO® Produkt interessiert. Wenn du uns den Gefallen tust und ein paar Fragen beantwortest, kannst du einen tollen LEGO Preis gewinnen. Das Ganze dauert nur etwa 3 Minuten! Gehe einfach zu der unten angegebenen Webadresse - dort findest du weitere Informationen.

Wir möchten gerne wissen, was Sie von Ihrem neuen LEGO Produkt halten. Wenn Sie uns helfen möchten, besuchen Sie bitte die u.a. Website, auf der Sie alles Weitere erfahren.



## Estimado usuario LEGO®

Al contestar algunas preguntas en Inglés, francés, alemán o japonés, en el sitio [www.acnielsen.aim.dk/lego](http://www.acnielsen.aim.dk/lego), podrás participar en el sorteo de algunos valiosos premios LEGO®.



## Caro Consumidor de LEGO®

Ao responder a algumas perguntas em Inglês, Francês, Alemão ou Japonês no endereço [www.acnielsen.aim.dk/lego](http://www.acnielsen.aim.dk/lego) irá participar num concurso para ganhar valiosos prémios de LEGO®.



## 抽選でレゴ®製品が当たります

あなたは、皆さんがお買い物のレゴ®製品についてどんな感想をお持ちか、知りたいと思っています。質問に答えて、新しいレゴ®製品の抽選に参加して、AOL、アンケートの調査には、あなたの意見とレゴ®が大好きな人！詳しくは、以下のウェブアドレスまでアクセスしてください。



[www.acnielsen.aim.dk/LEGO](http://www.acnielsen.aim.dk/LEGO)



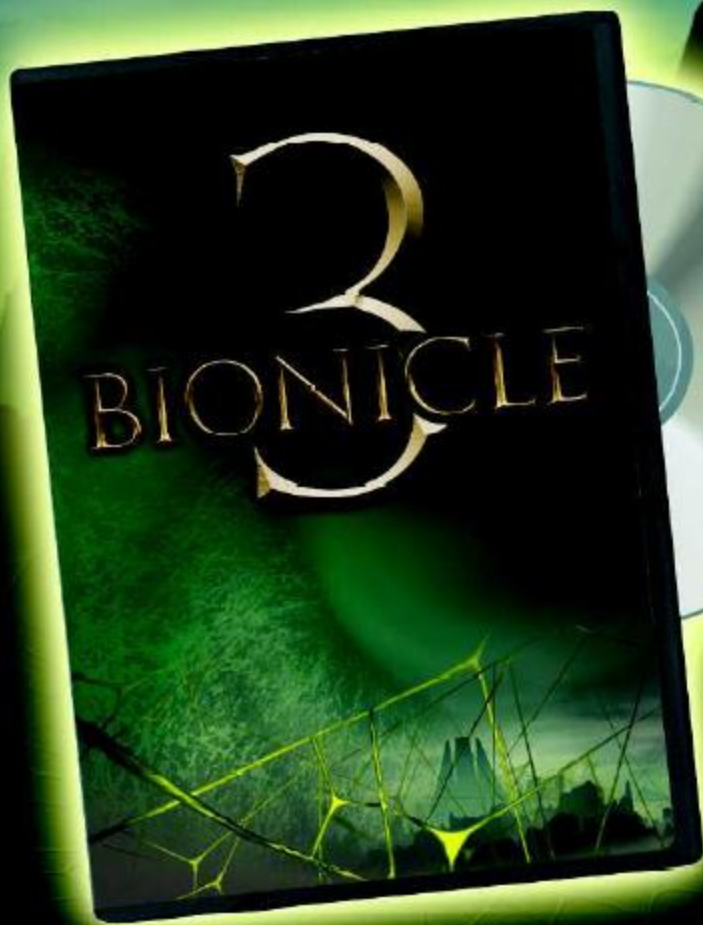

DVD  
VIDEO

VIS

M

[www.bionicle.com](http://www.bionicle.com)