



# STAR WARS



7930



1

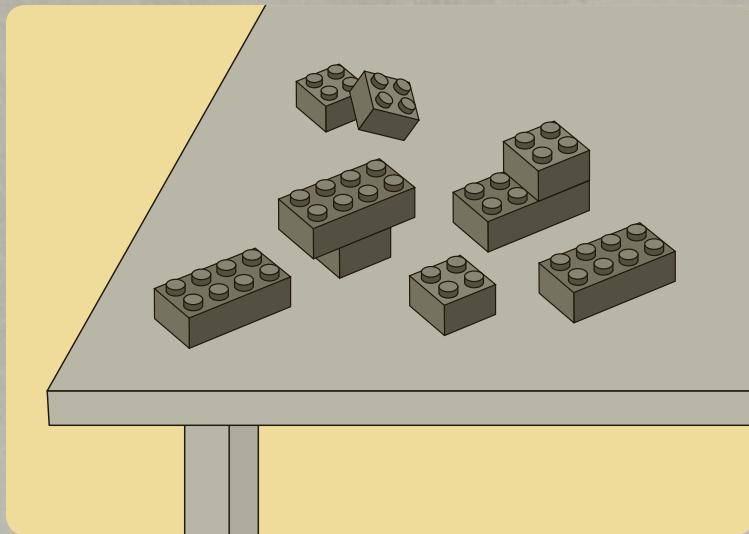

2





1



2

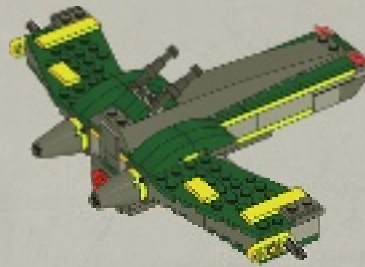
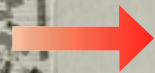

3

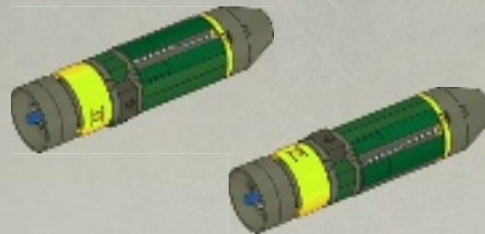
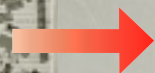

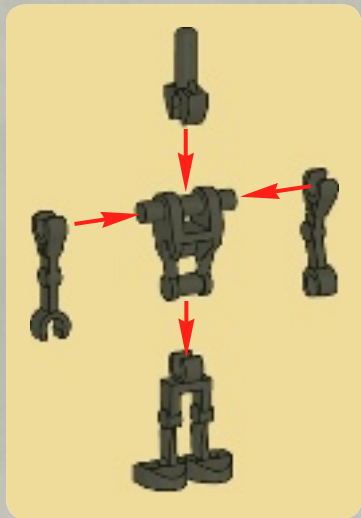



1

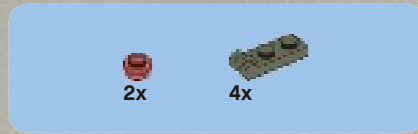
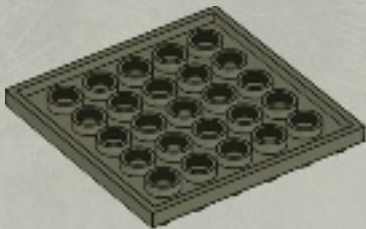

2

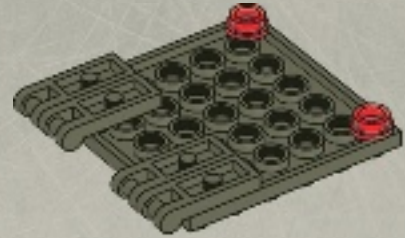

3

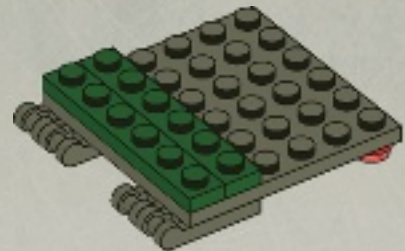



2x

# 4

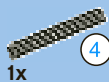
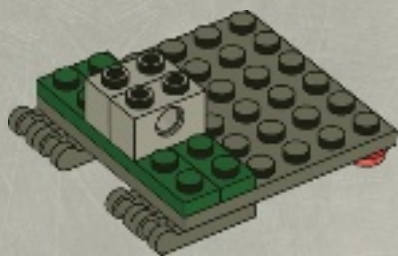

1x

4



2x

# 5

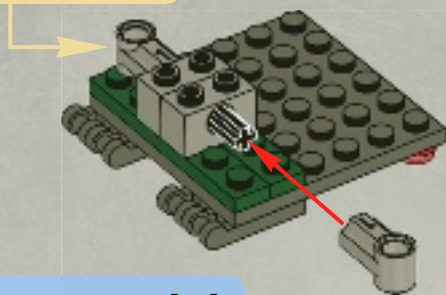
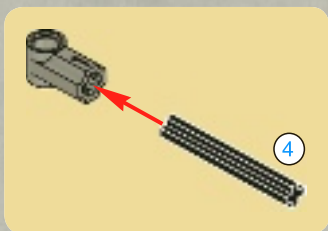

4

1:1

6



1x



2x

# 6

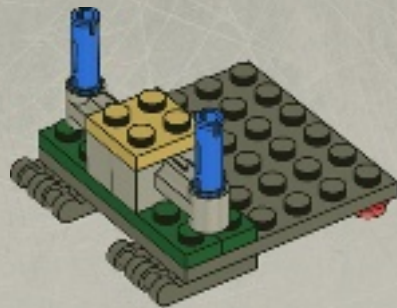

2x



1x



1x

# 7

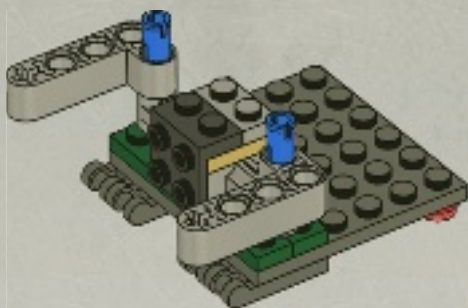

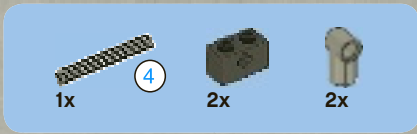

8

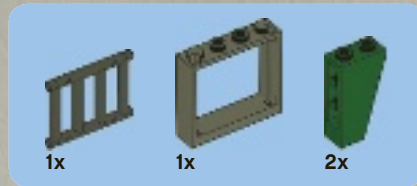
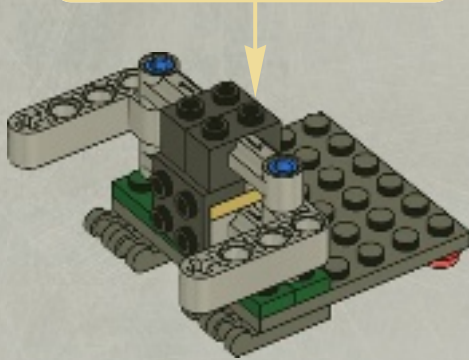
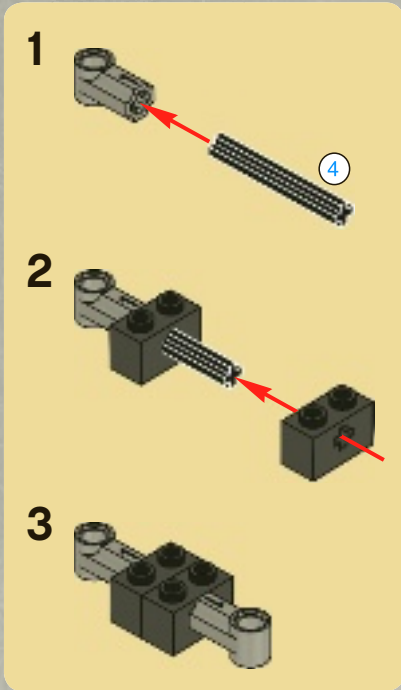

9

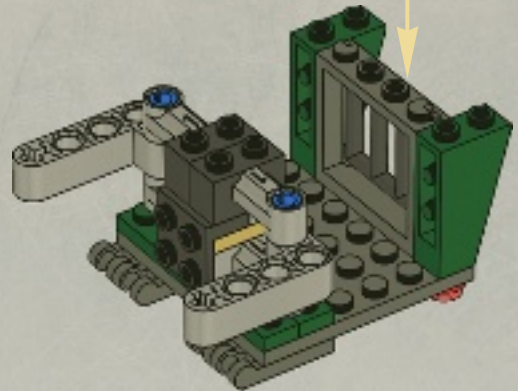
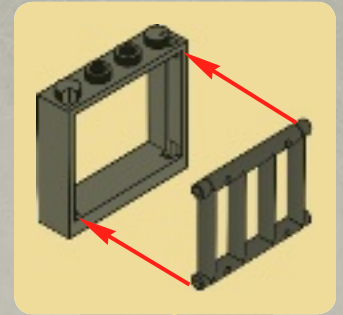

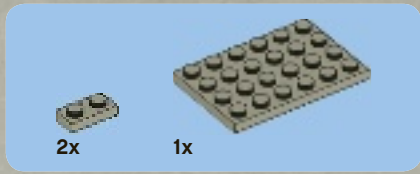

# 10

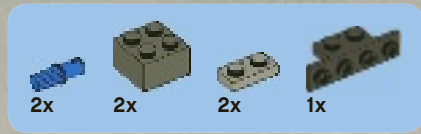
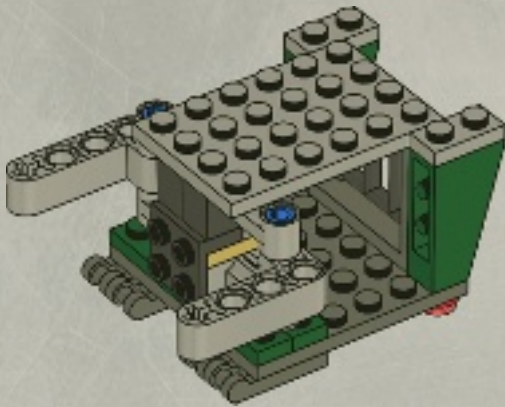

# 11

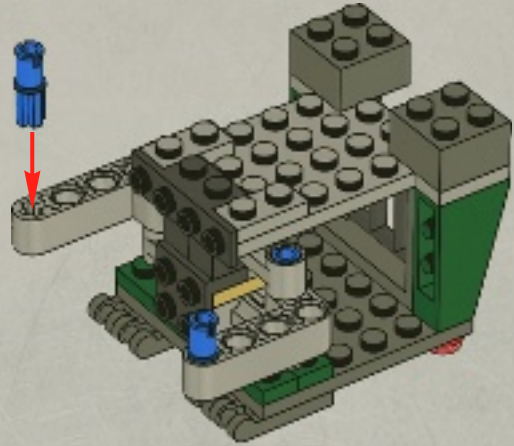





2x



2x

# 12

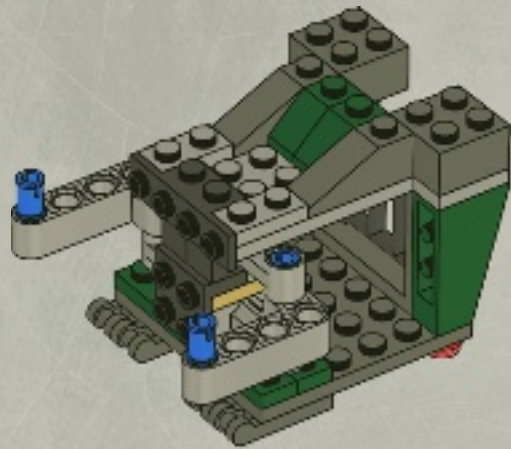

1x

# 13

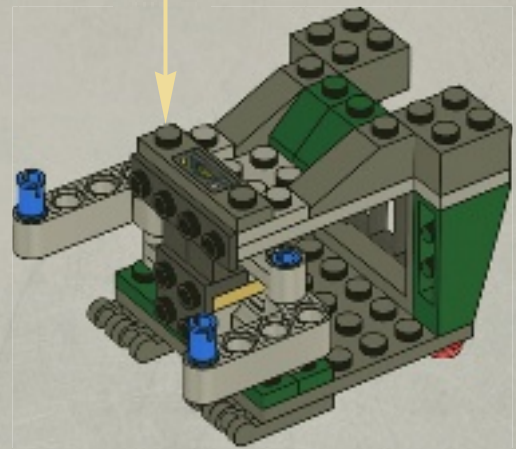
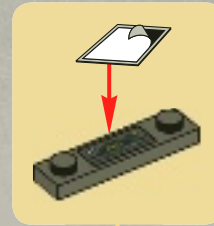



# 14

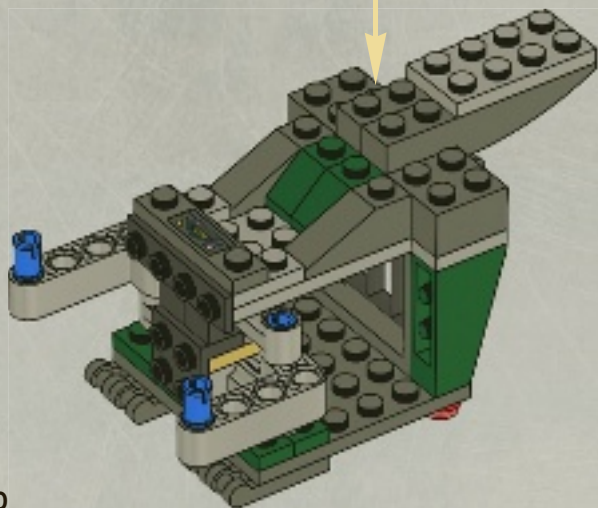
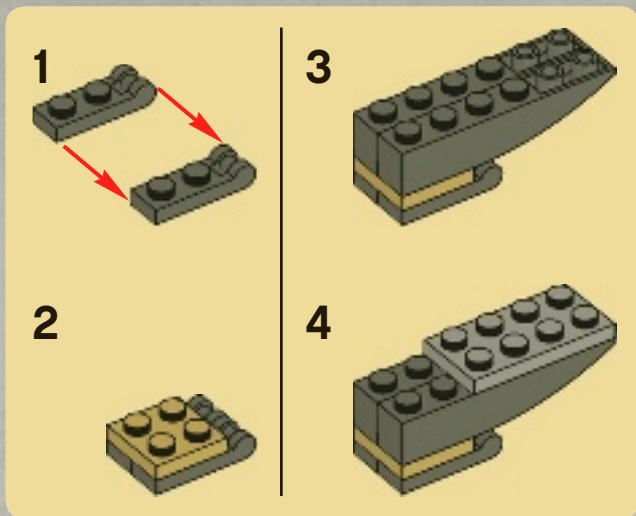

# 15

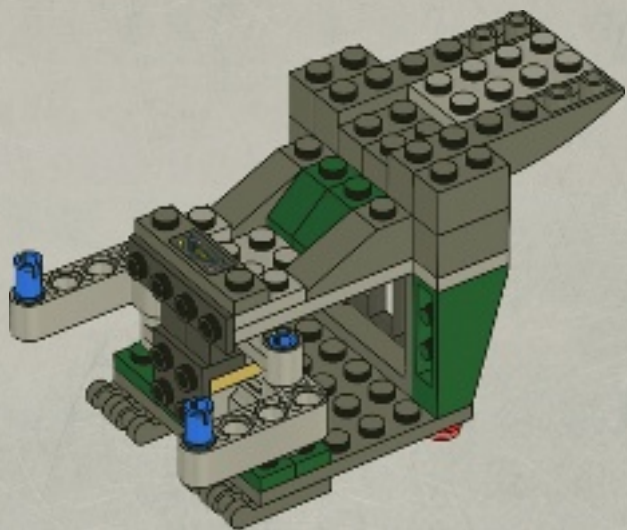



2x

2x

# 16

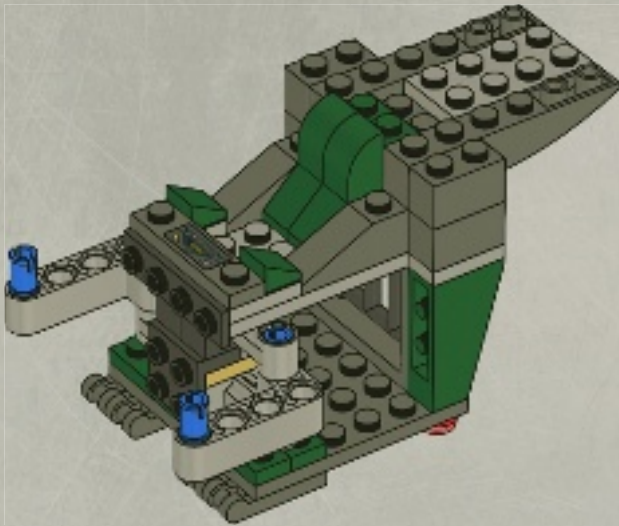

2x



4x



1x

# 17

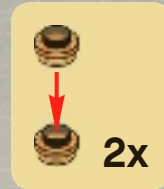

2x

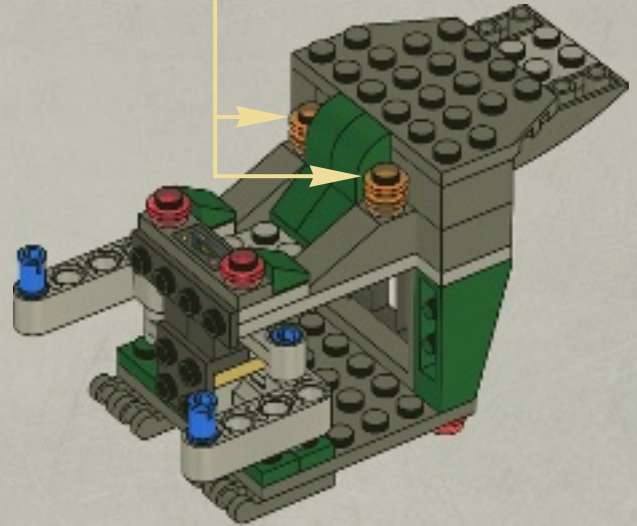

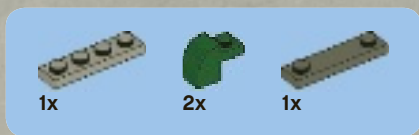

# 18

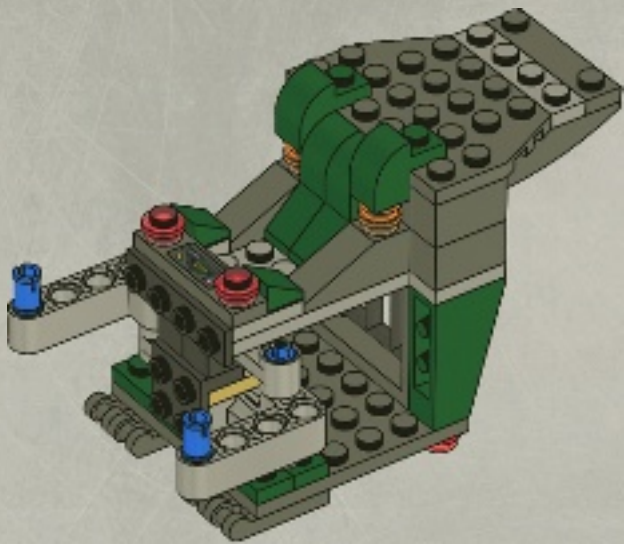

# 19

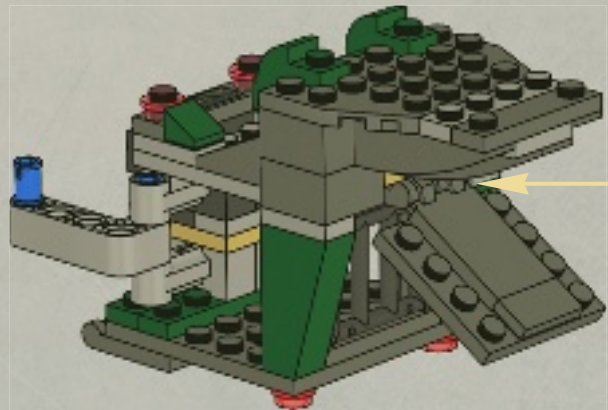
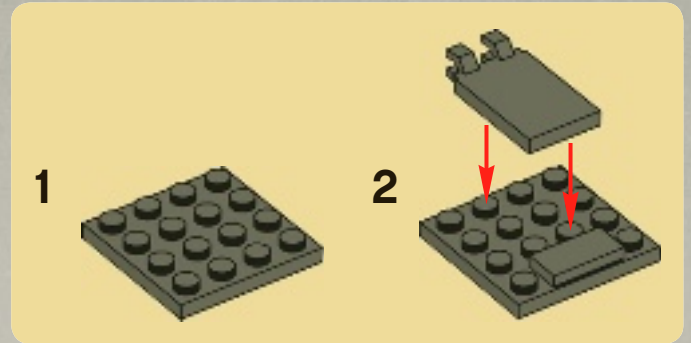



2x



2x



2x

# 20

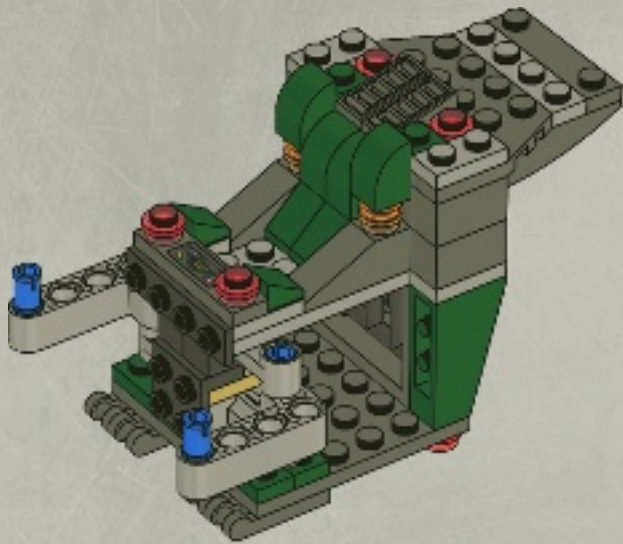

1x



2x



1x

# 21

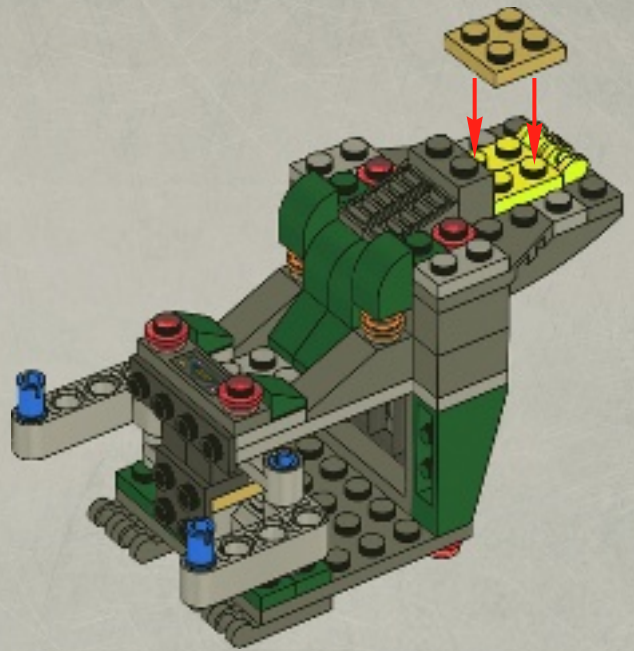



22

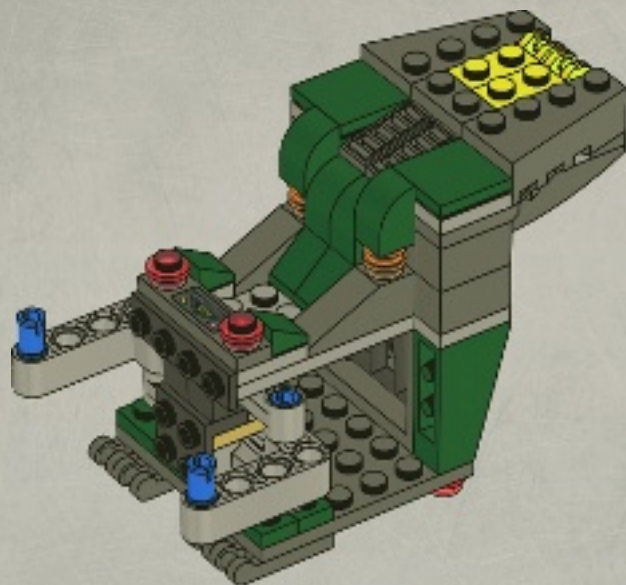



# 23

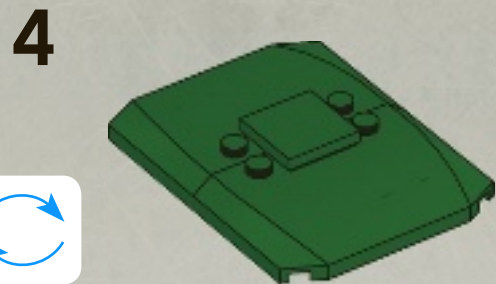
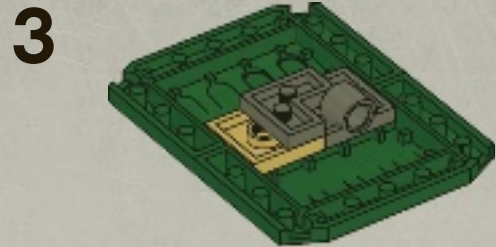
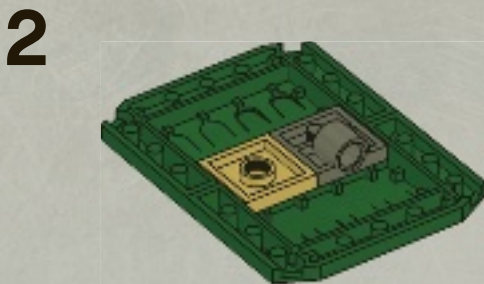
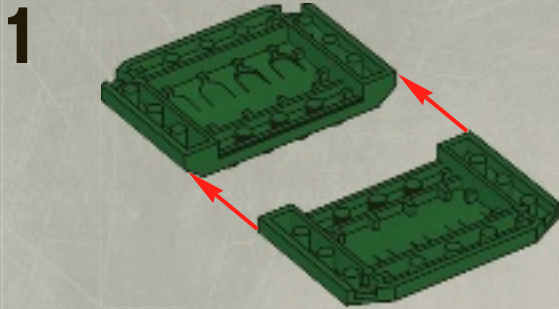

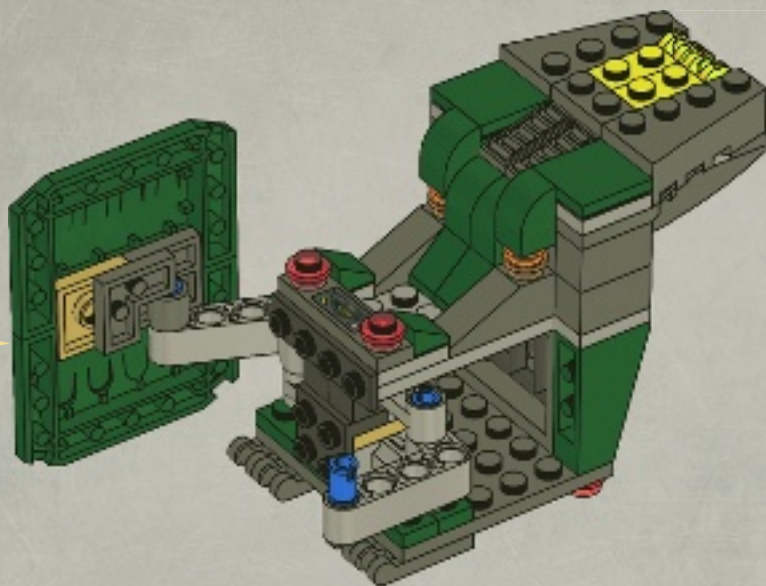





# 24

## 1

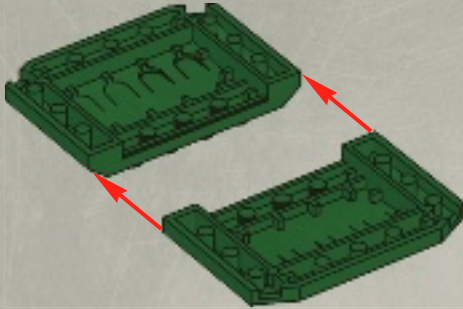

## 2



## 3

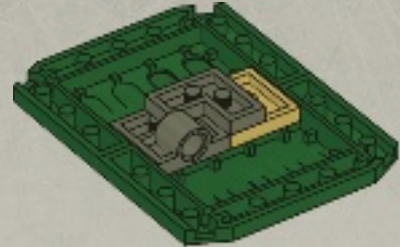

## 4

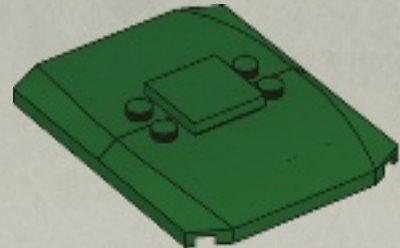

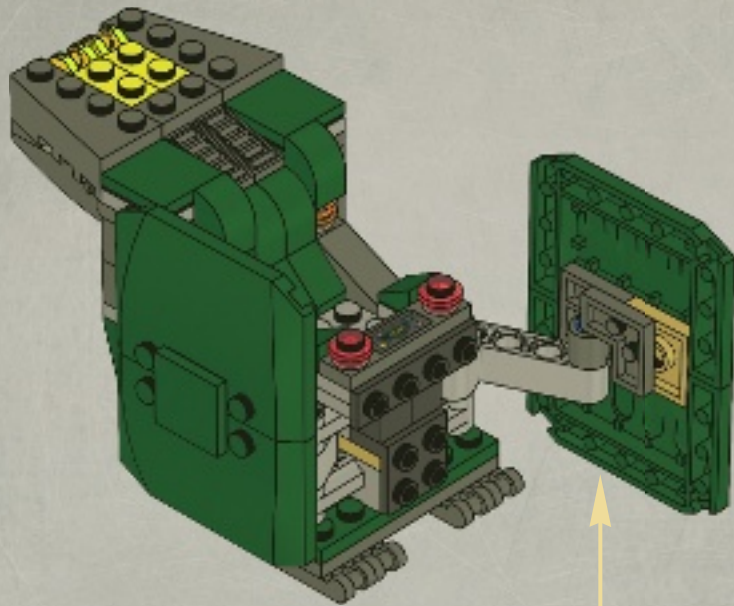



2x

1

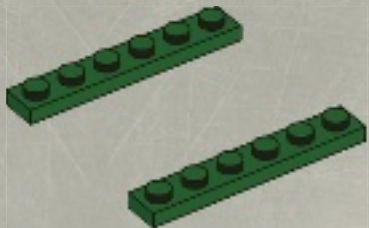

1x

2

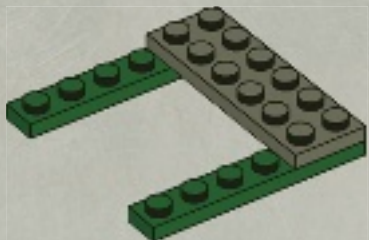

1x



2x

3

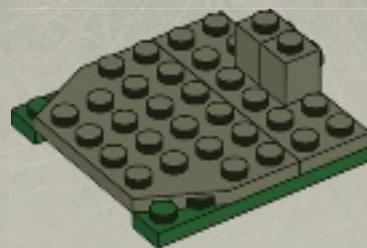

1x



1x

4

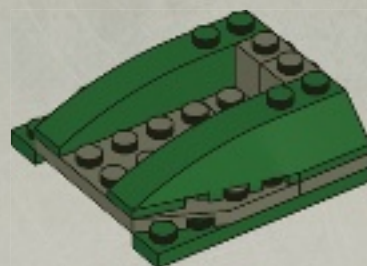



5

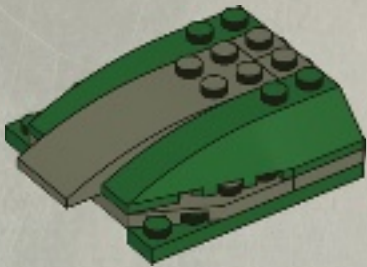

25

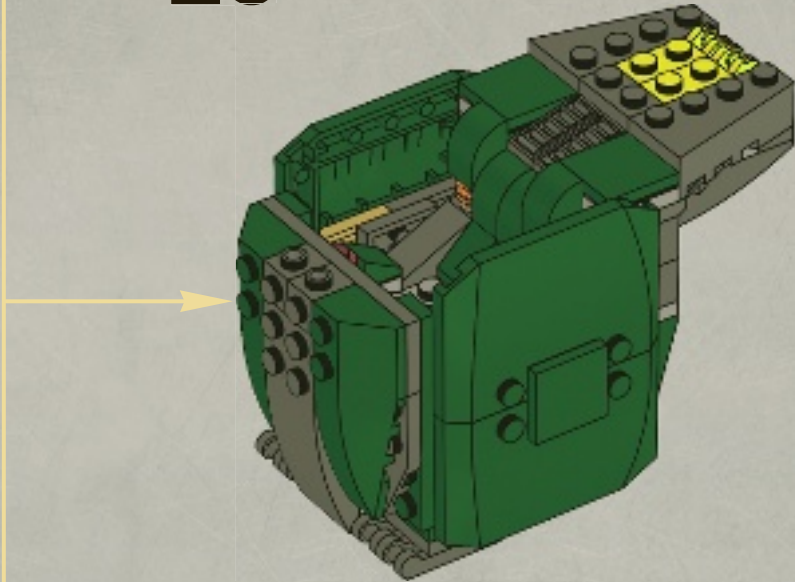

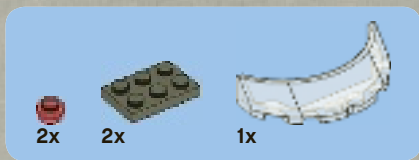

# 26

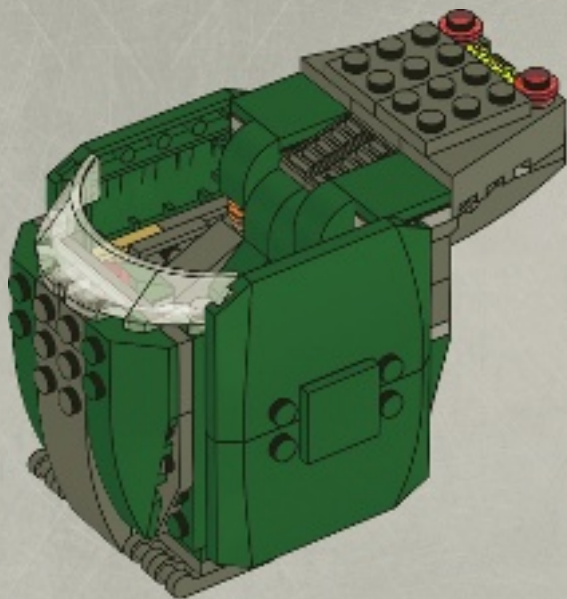

# 27

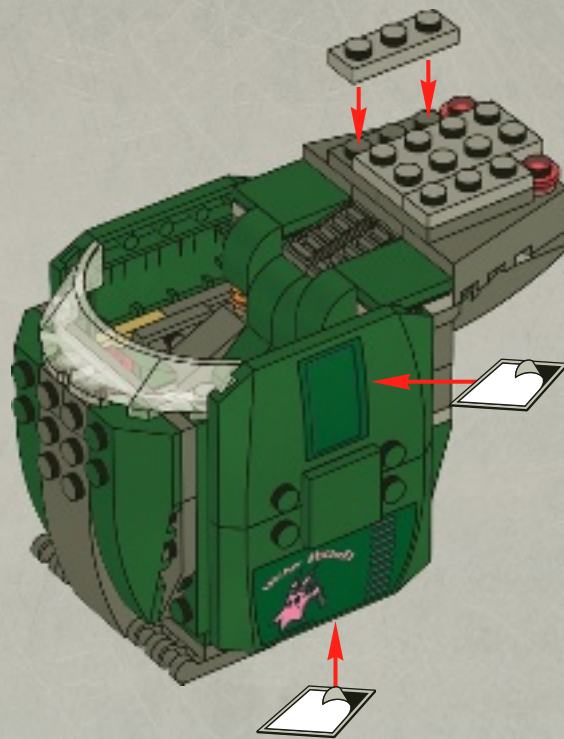



1x



1x

# 28

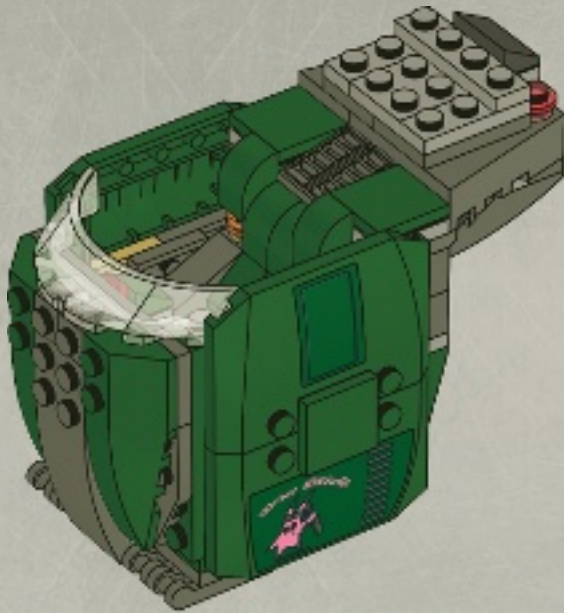

1x



1x



2x

# 29

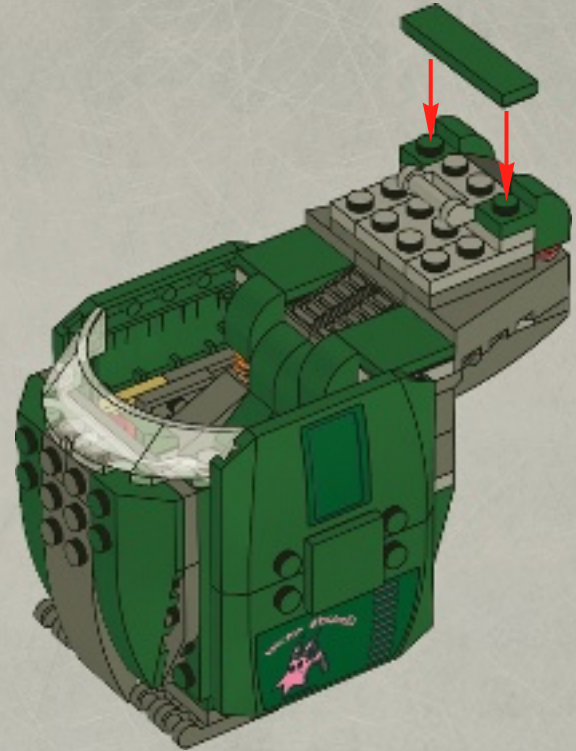



2x



4x



4x

# 30

1



2

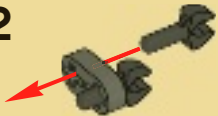

3



2x

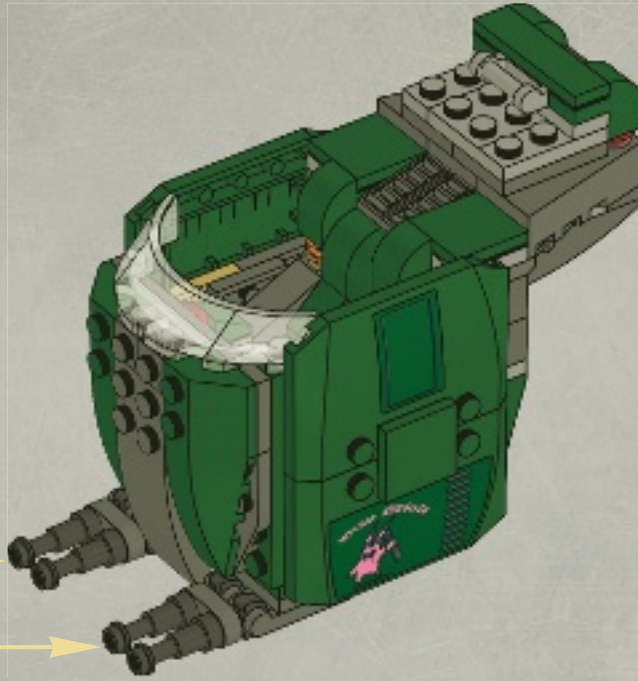

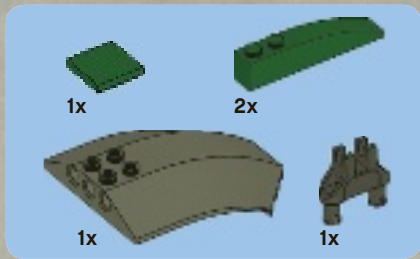

# 31

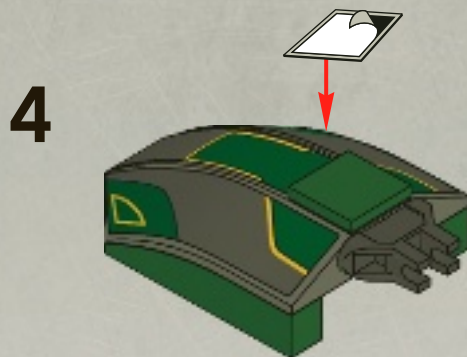
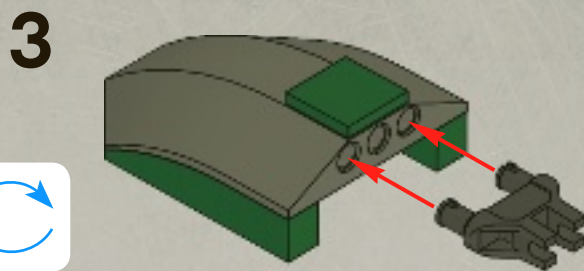
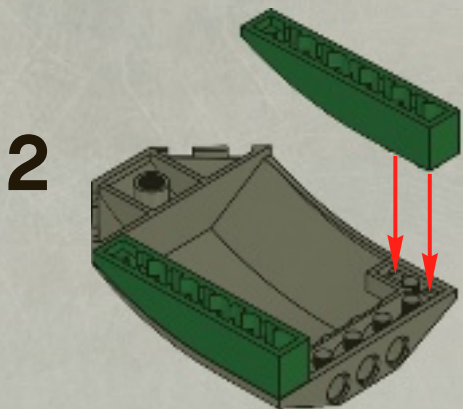



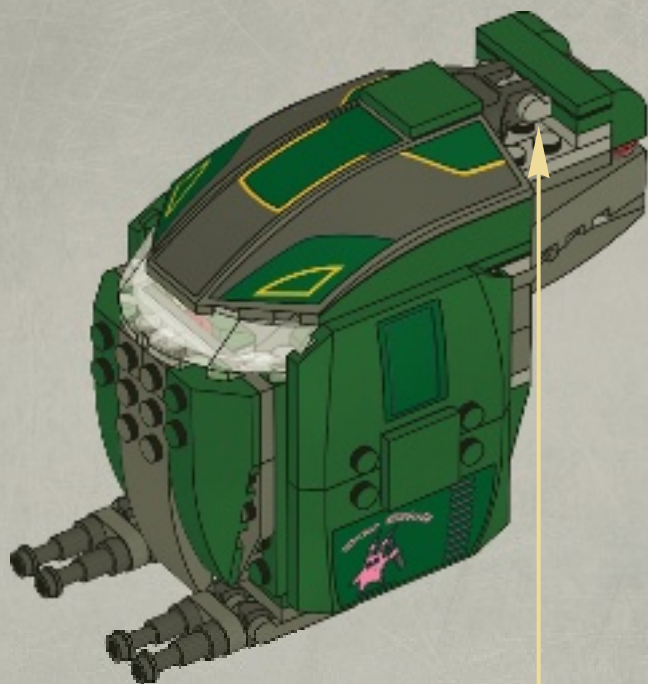

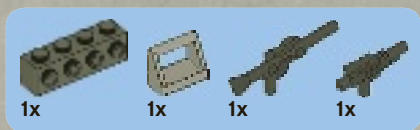

# 32

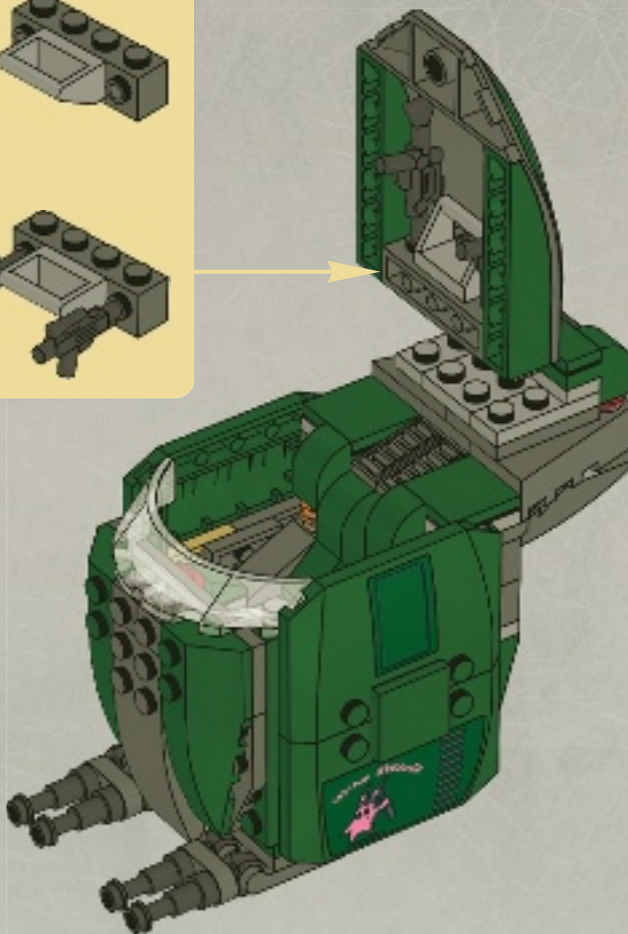
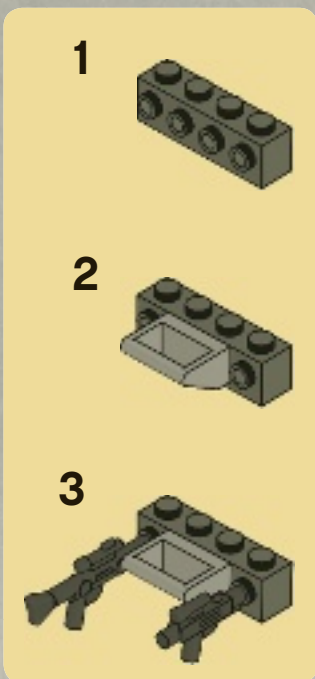

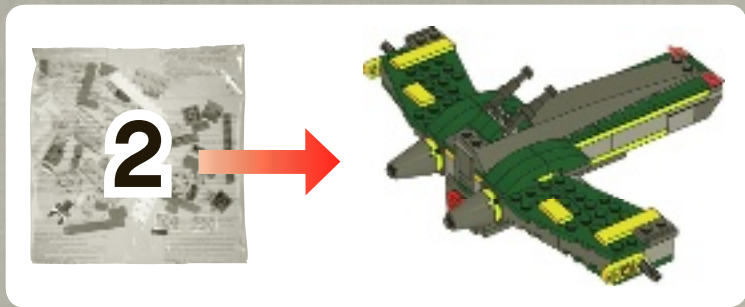

1

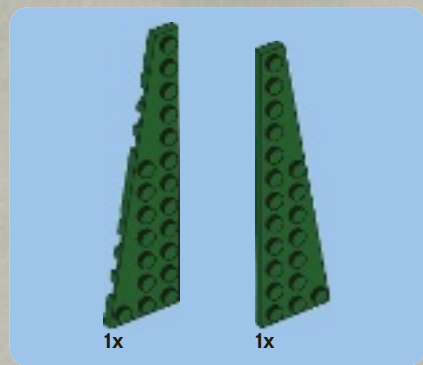
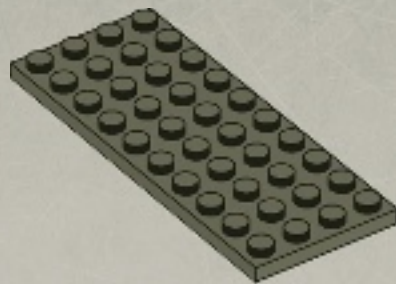

2

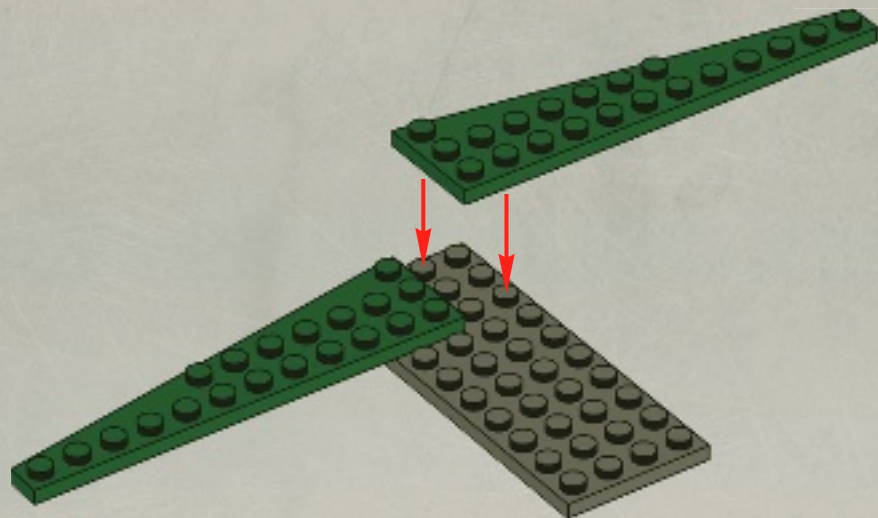

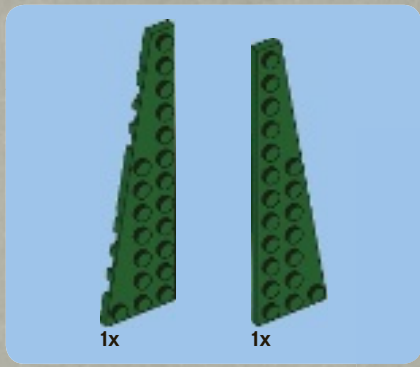

3

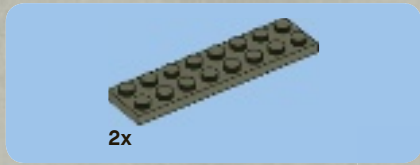
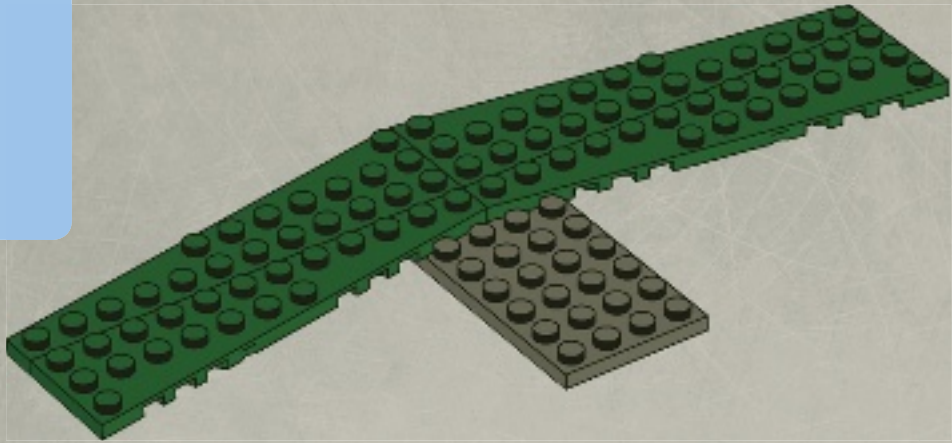

4

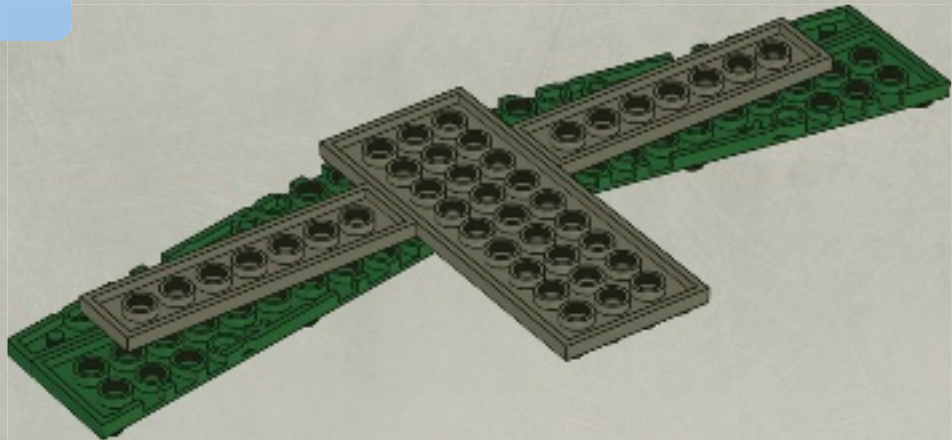



2x



1x



1x

5

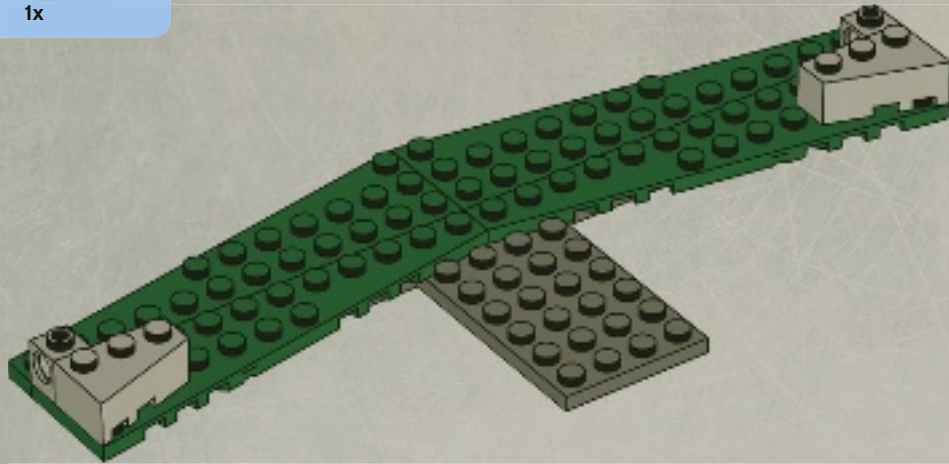

2x



2x



2x

6

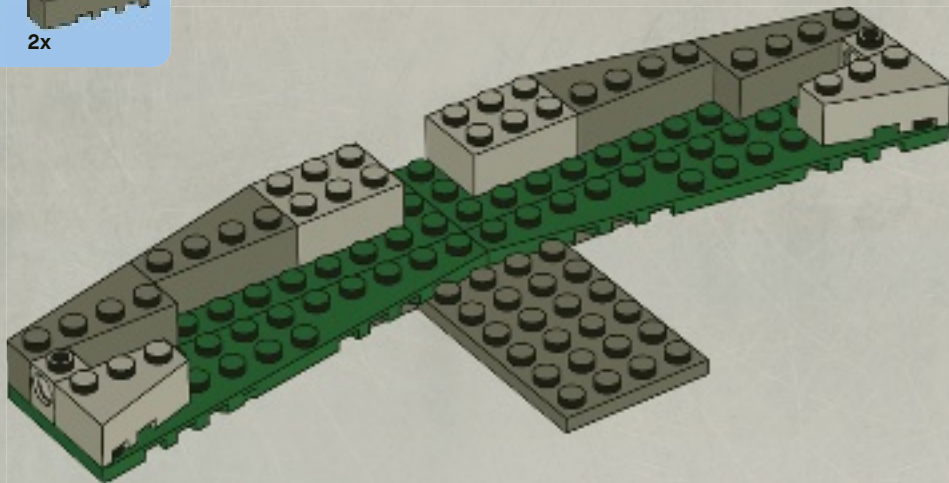



2x



1x

7

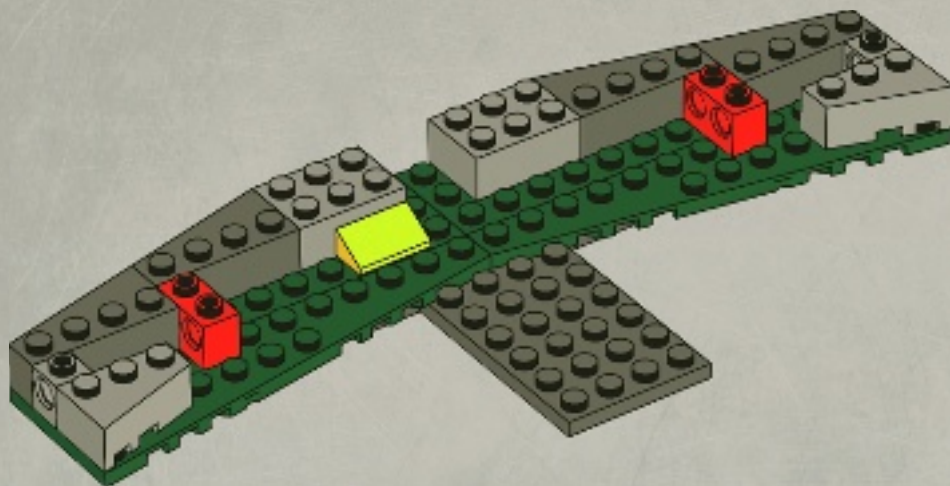

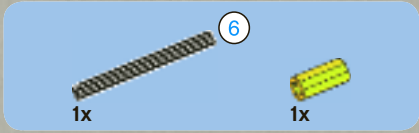
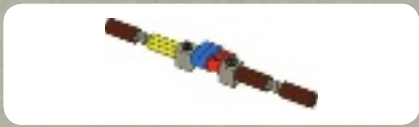

1

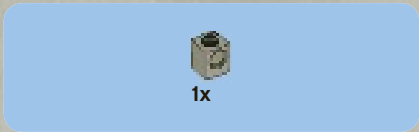
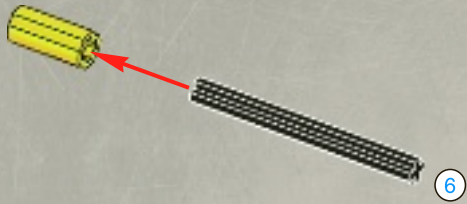

2

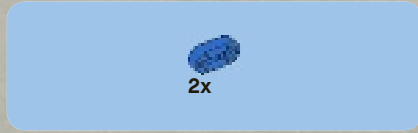
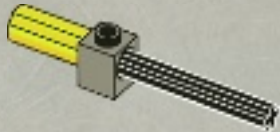

3

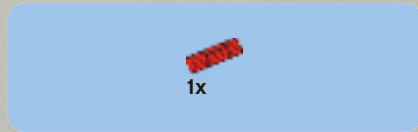
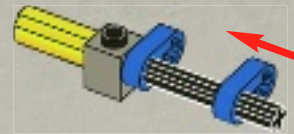

4

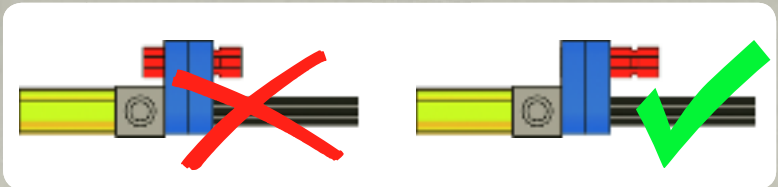



1x

5

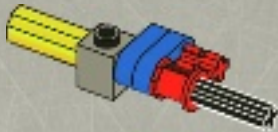

1x



1x

6

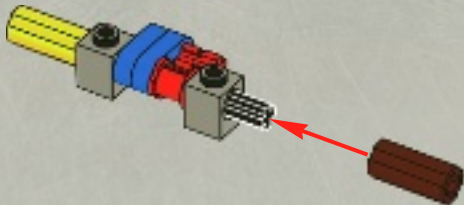

2x

3



3

1:1

7

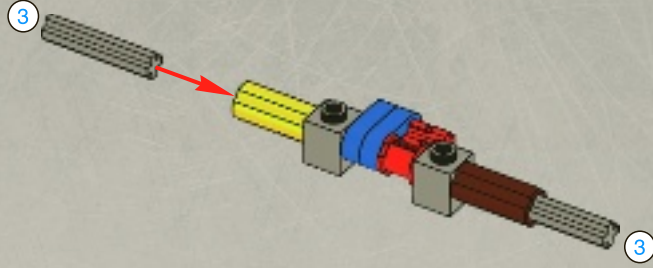

2x

8

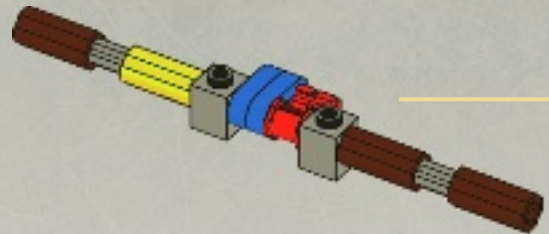





8

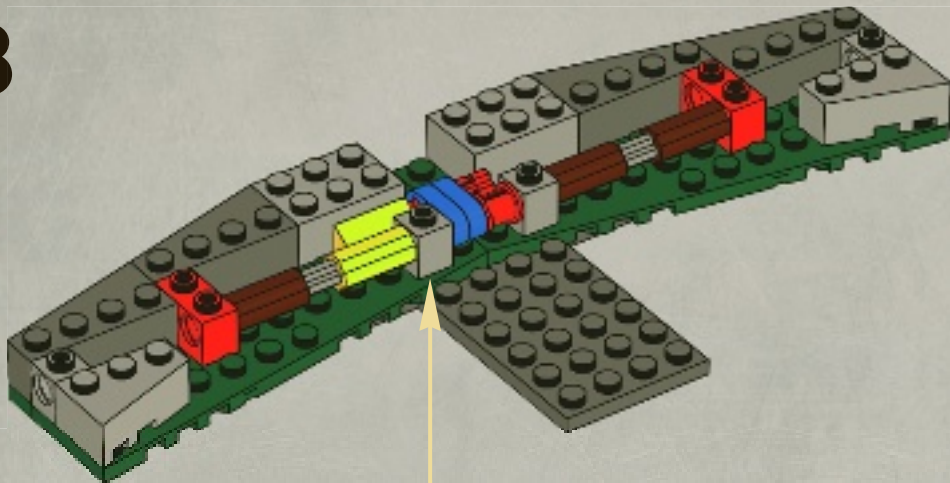

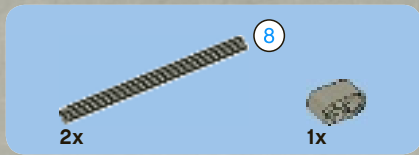

9

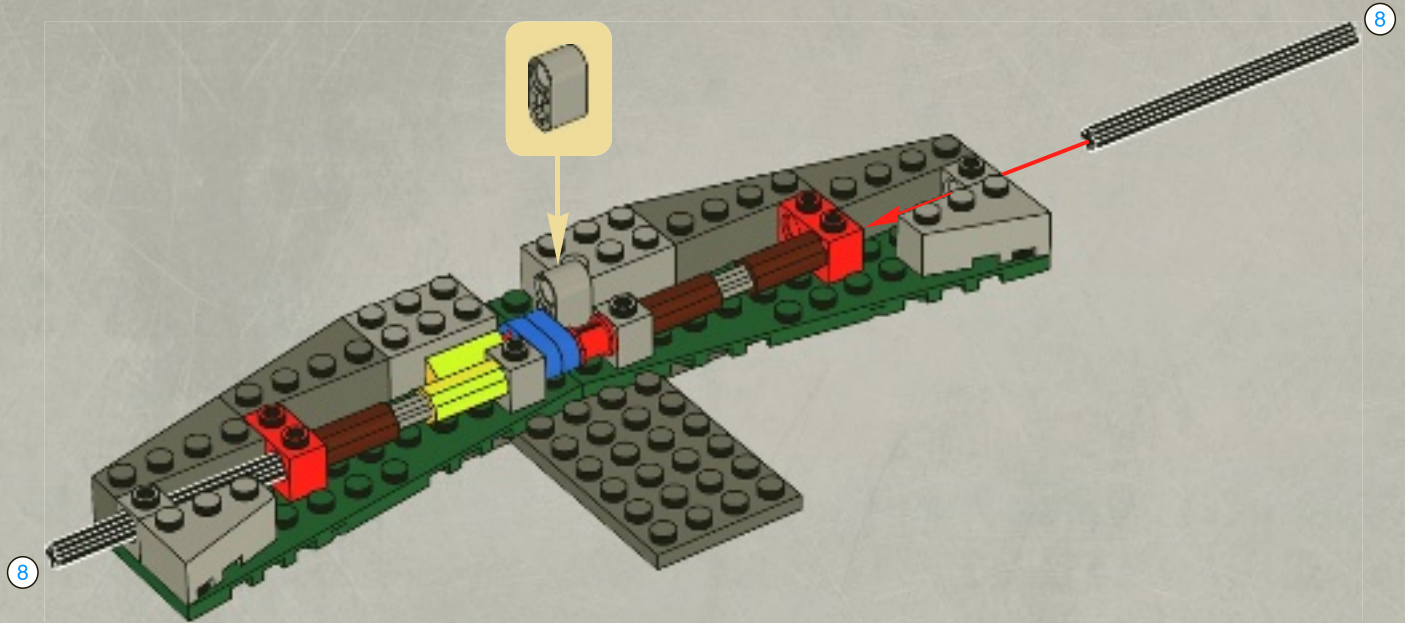



2x

# 10

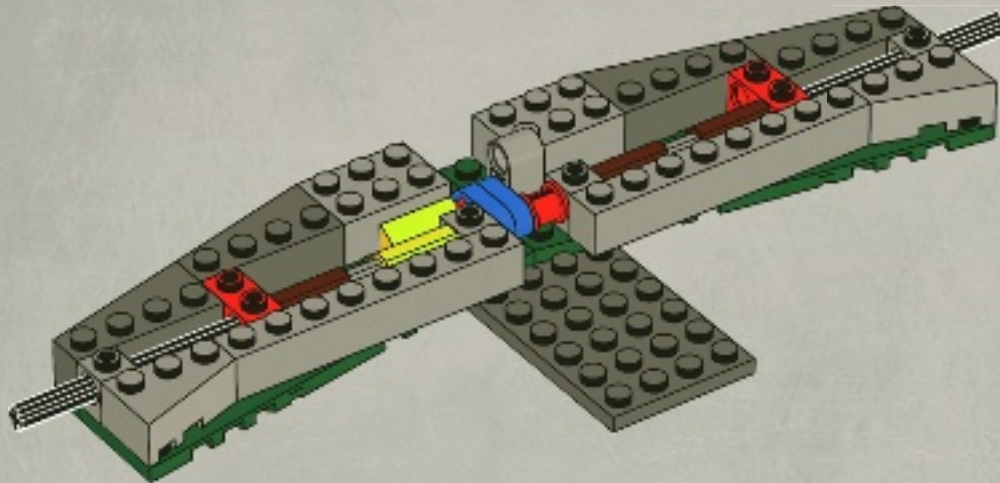

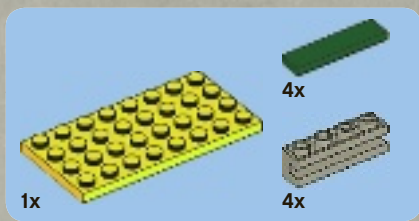

# 11

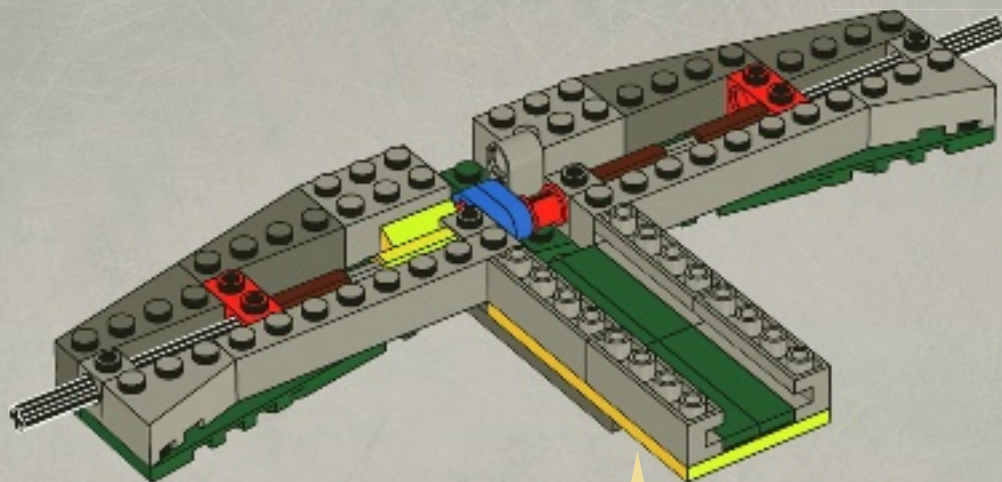

1

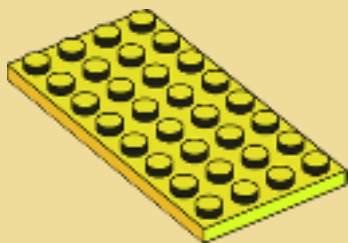

2

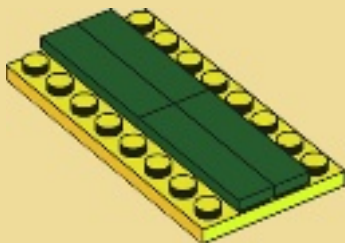

3

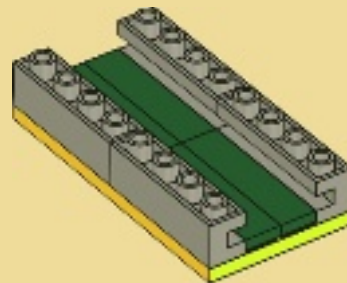



1x

1

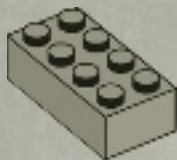

2x

2

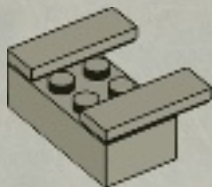

2x

3

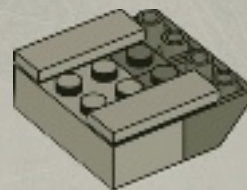

1x



1x

4

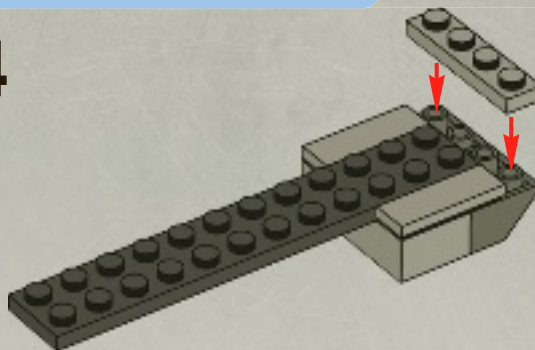



2x

5

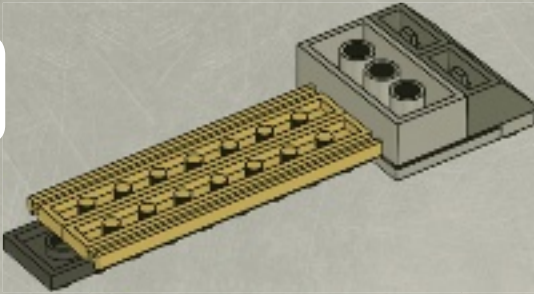

2x



1x

6

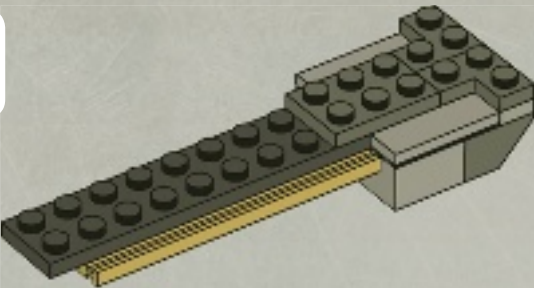

2x



2x



2x

7

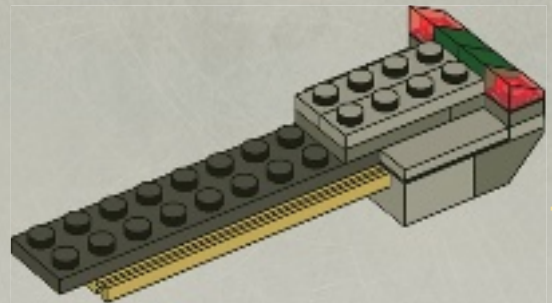

12

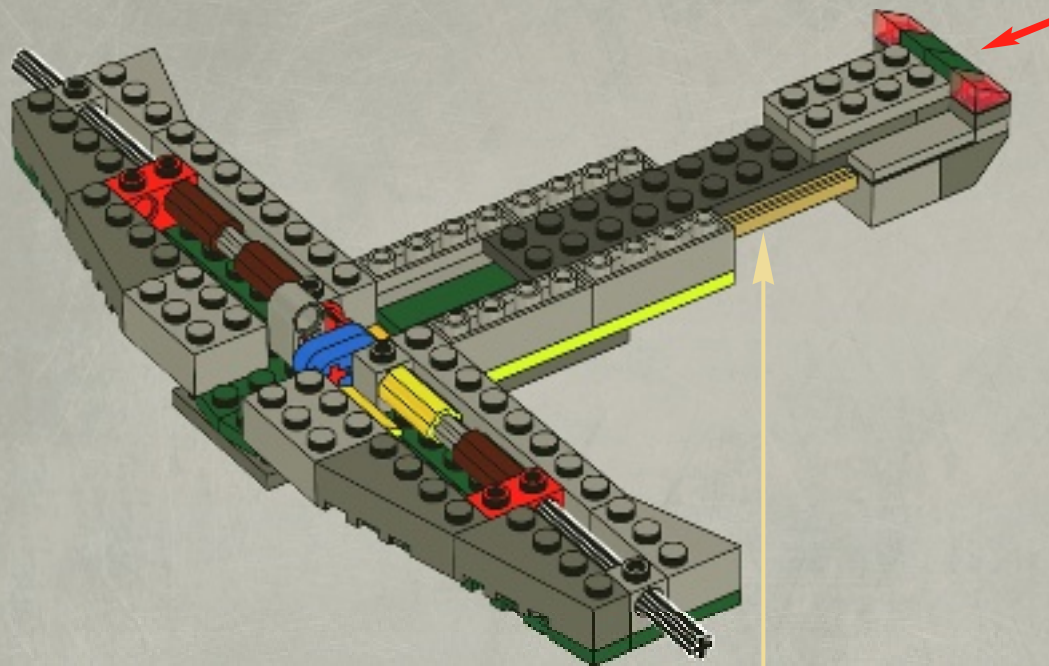



# 13

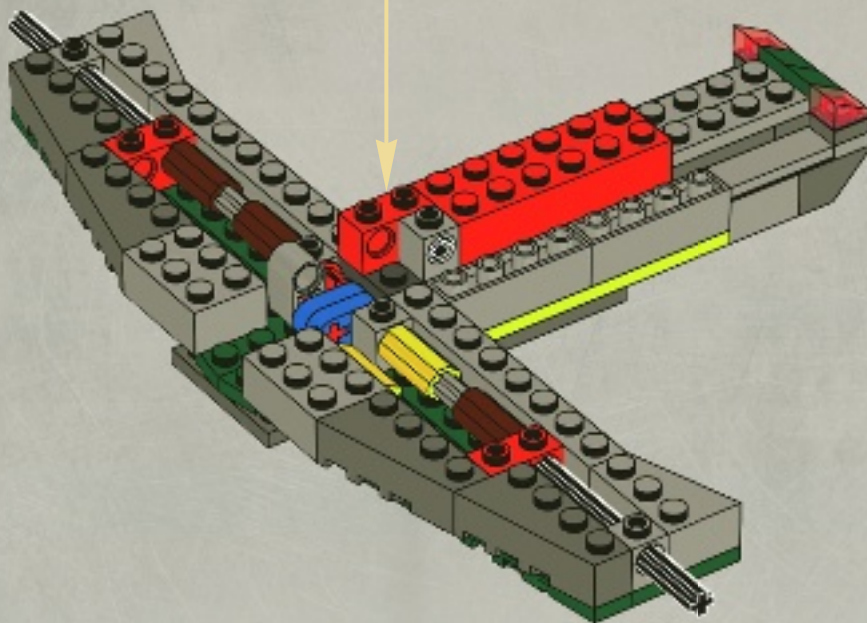



2x



1x

# 14

1



2

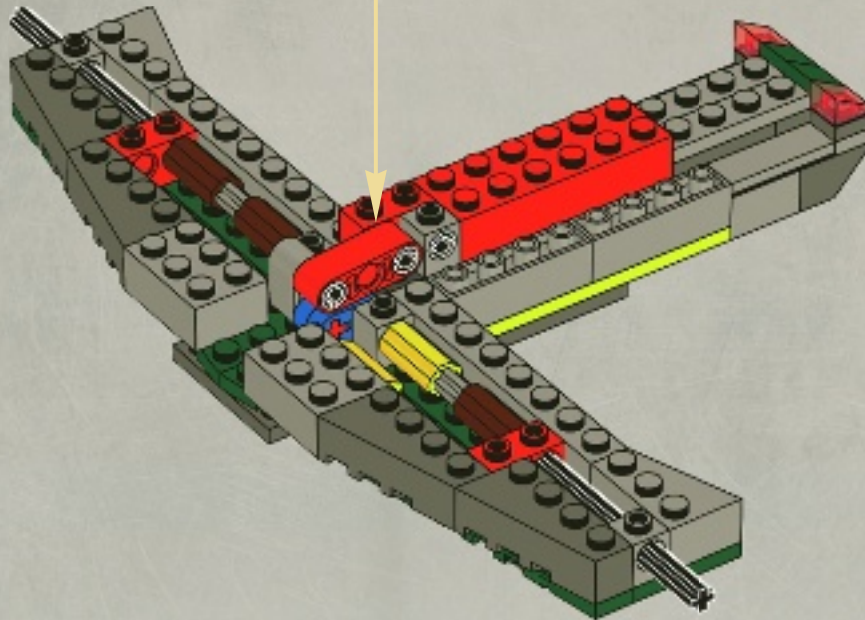



# 15

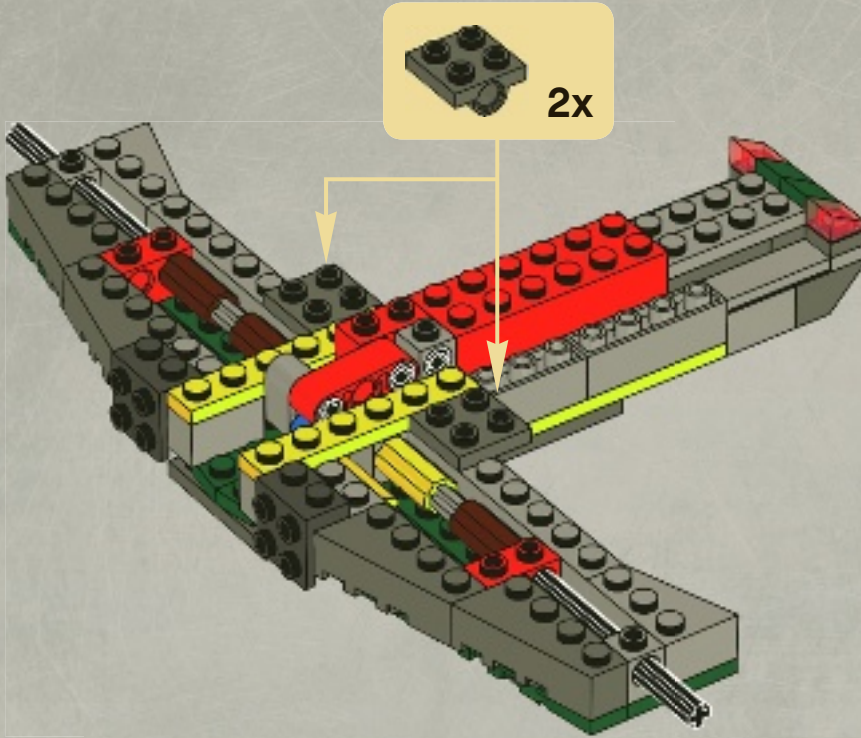

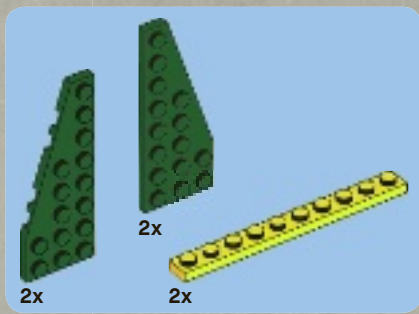

16

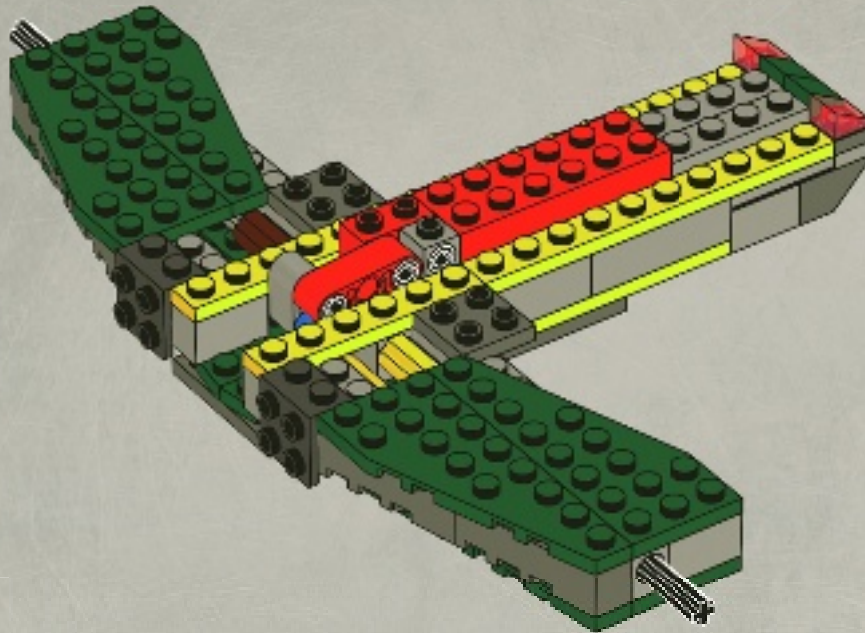



2x

17

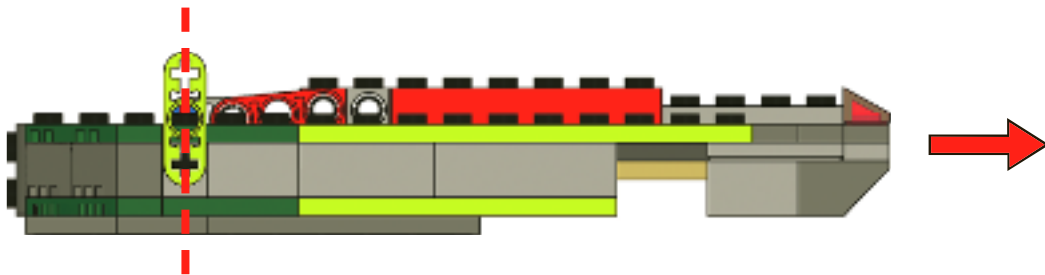
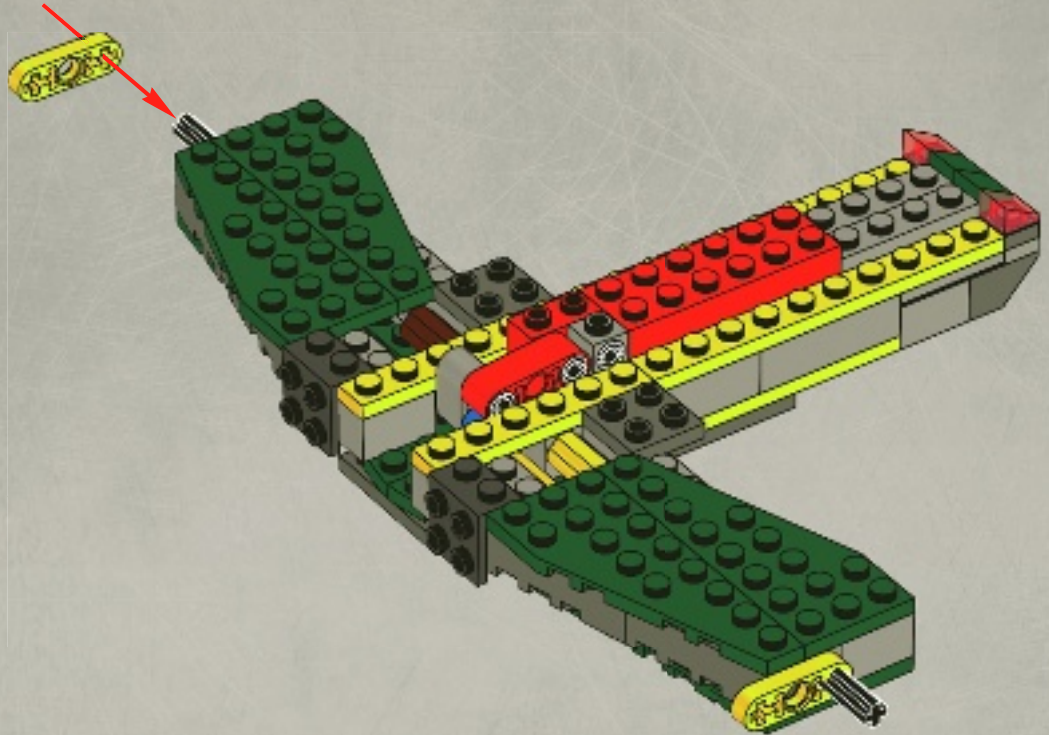

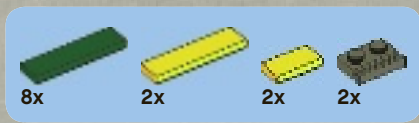

18

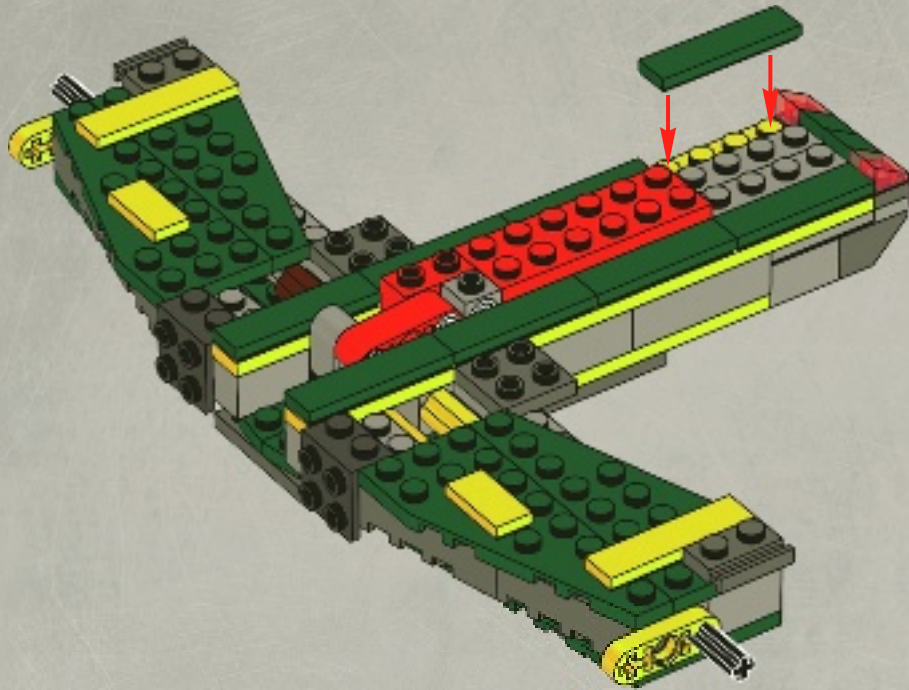

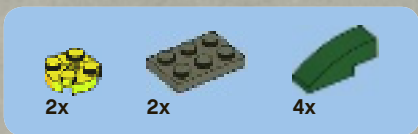

# 19

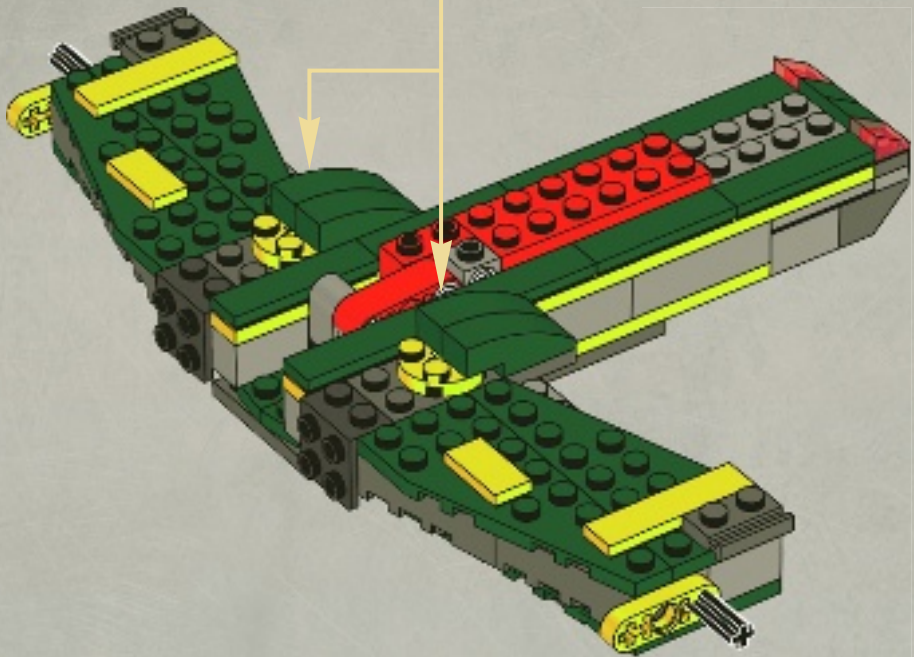



# 20

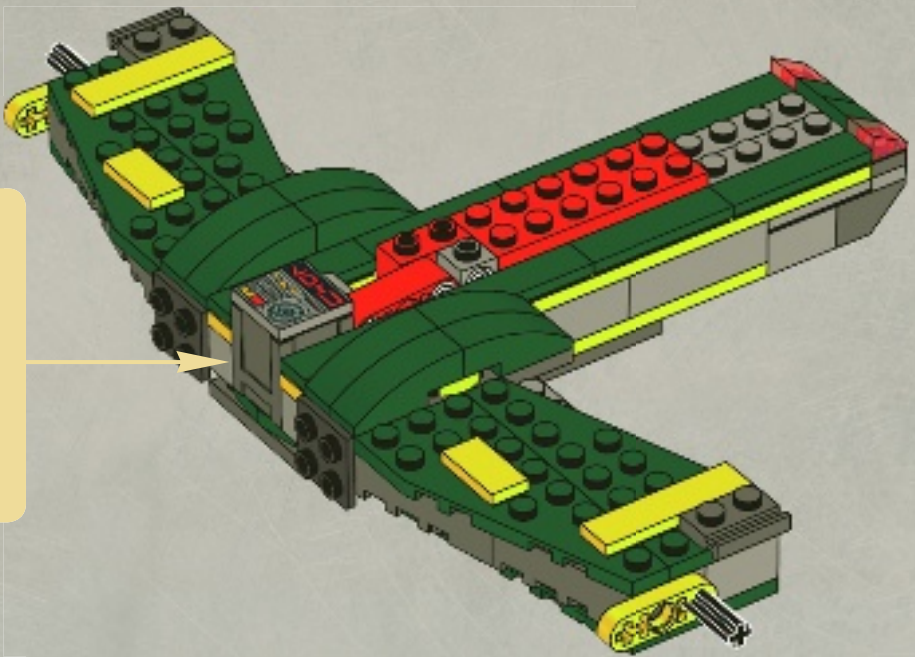
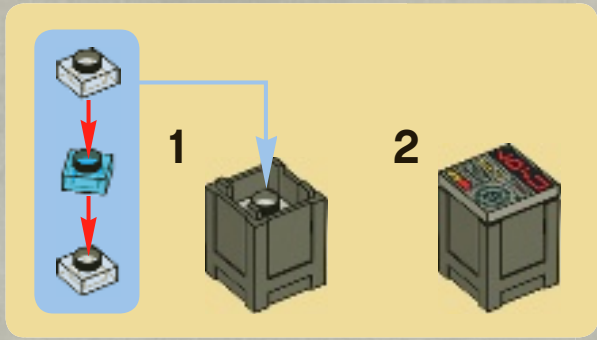



2x

# 21

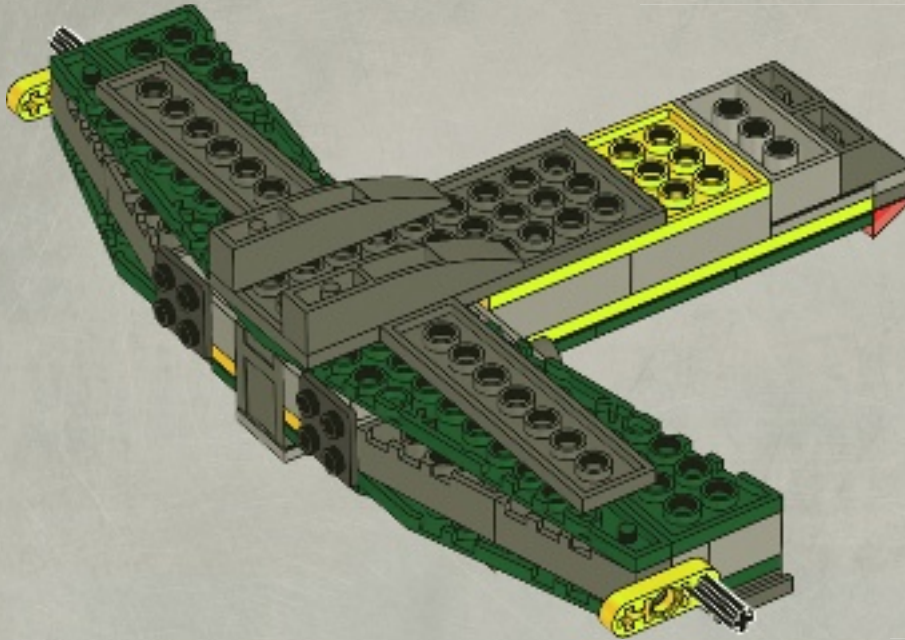





# 22

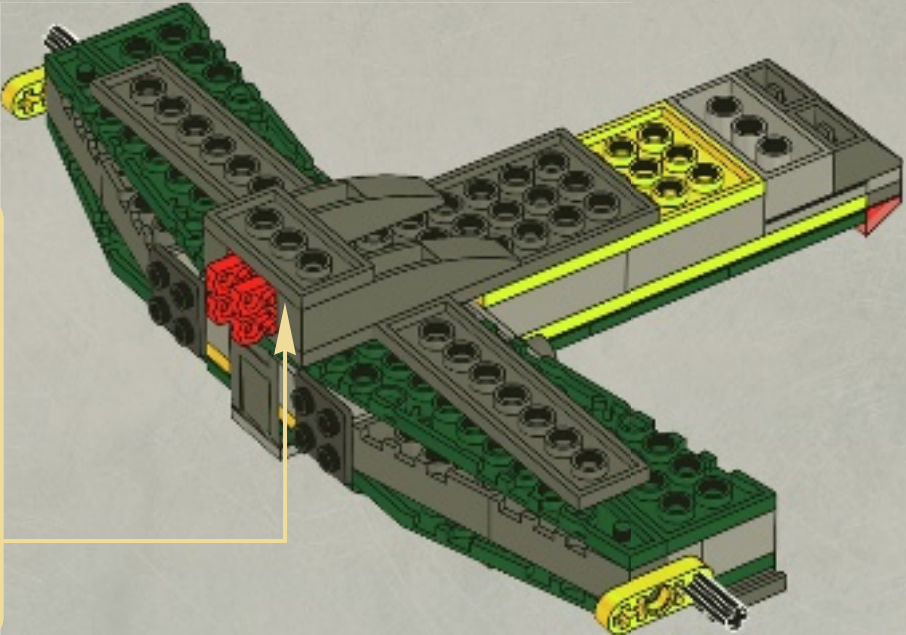
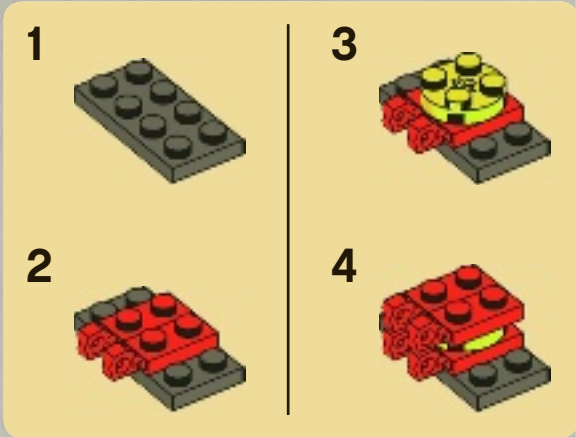



23

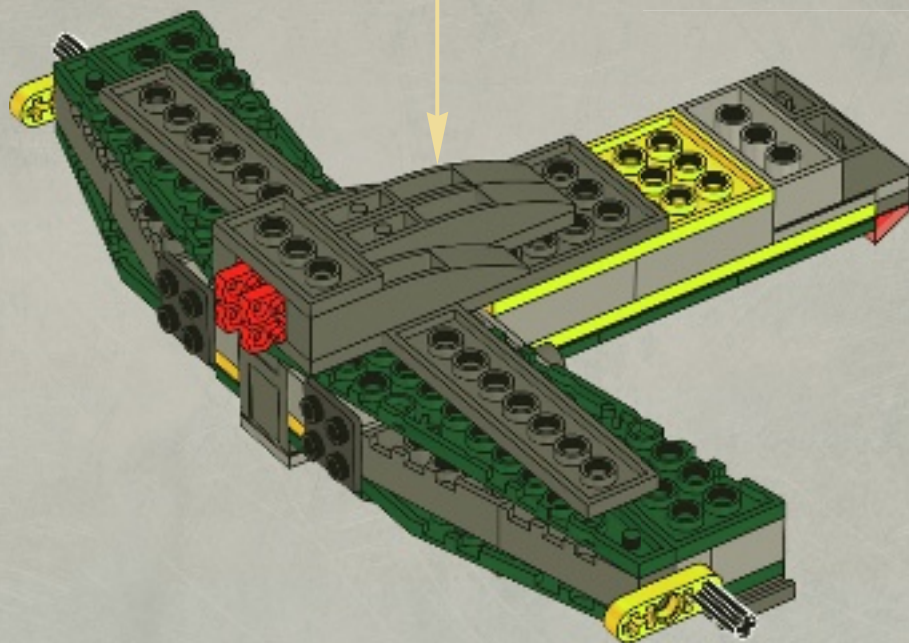
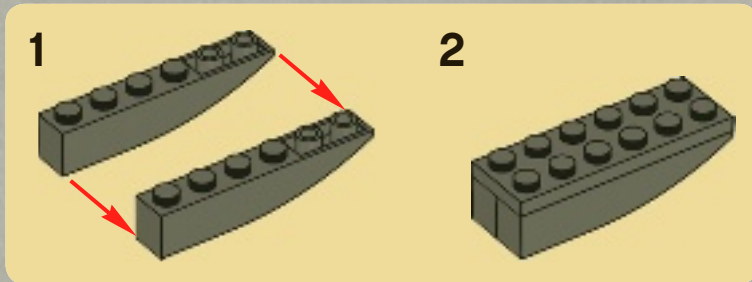



1x

# 24

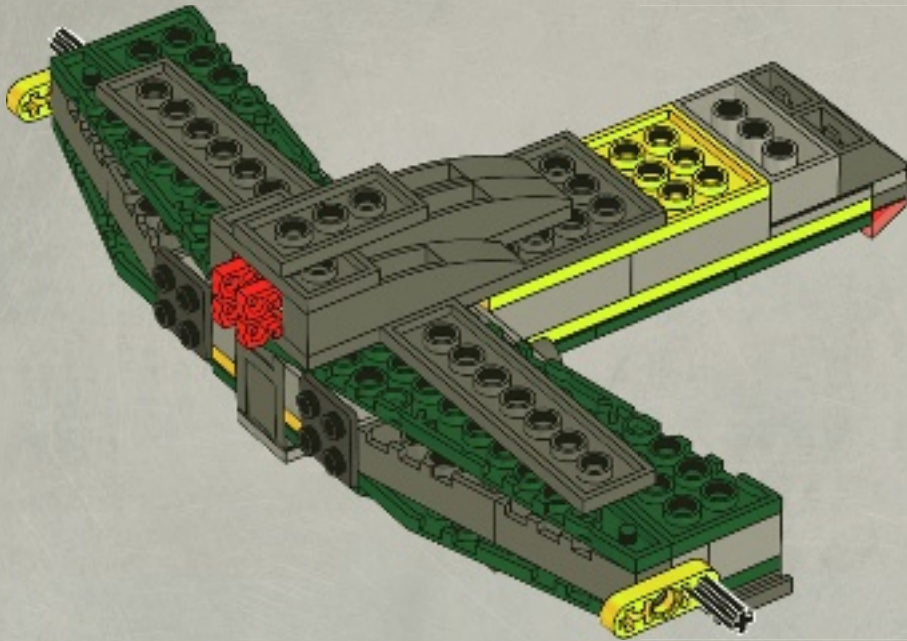



2x



2x



1x

# 25

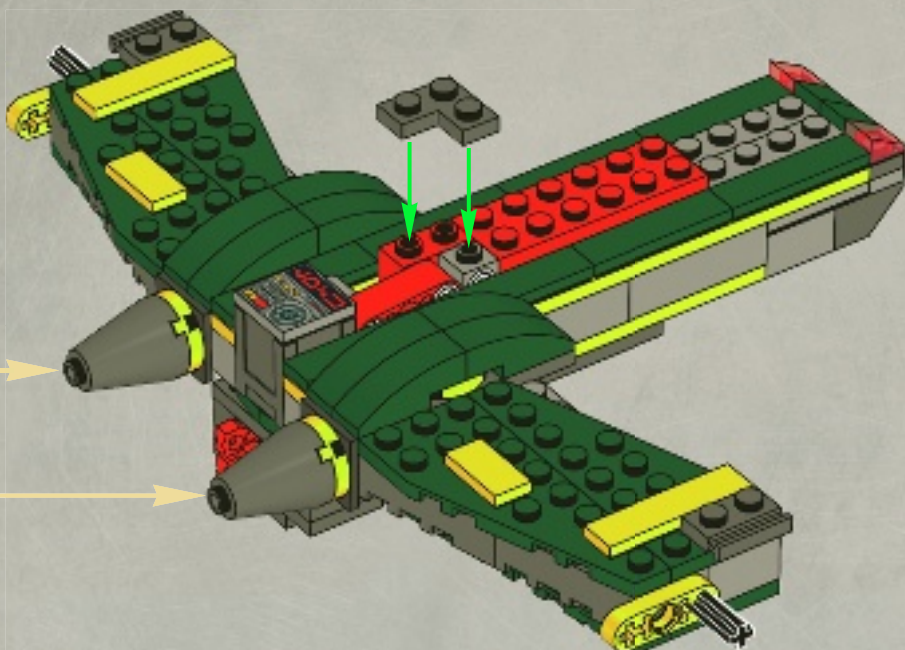

2x

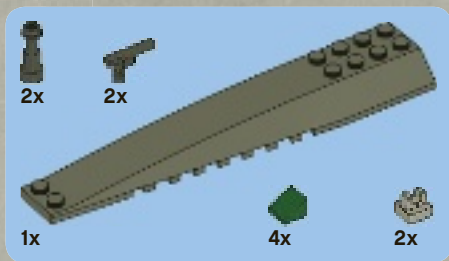

# 26

## 1

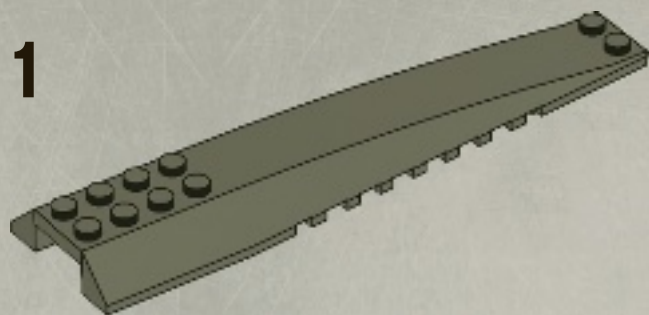

## 2

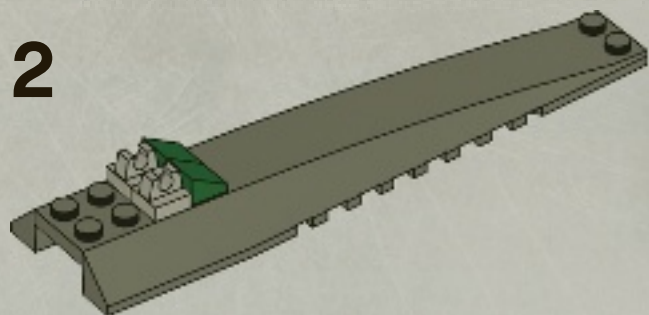

## 3

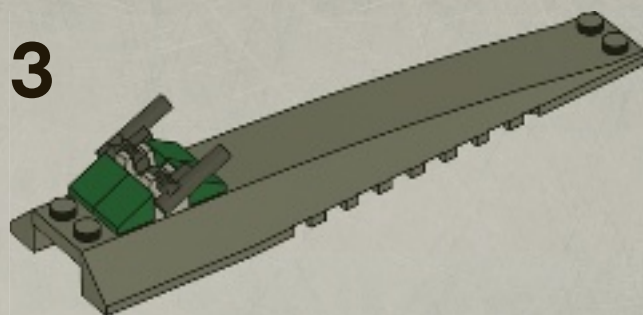

## 4

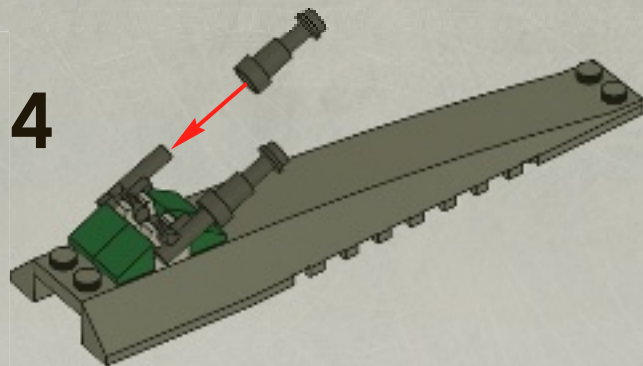

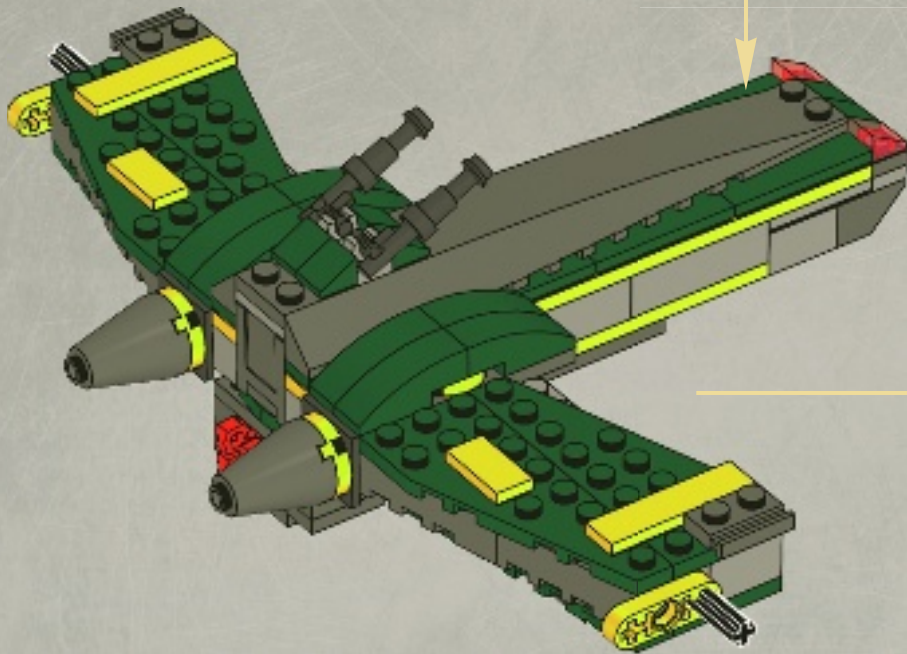

27

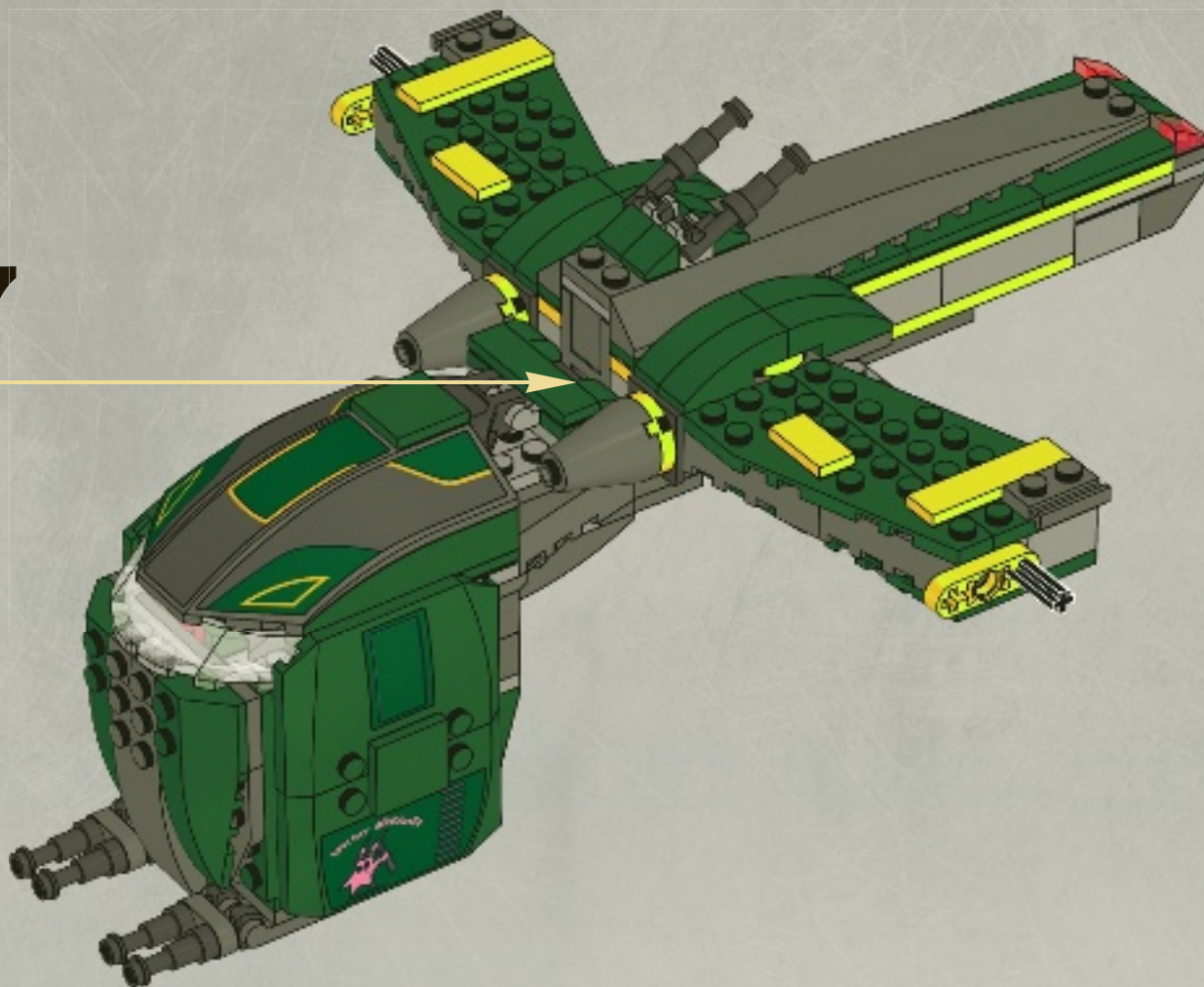

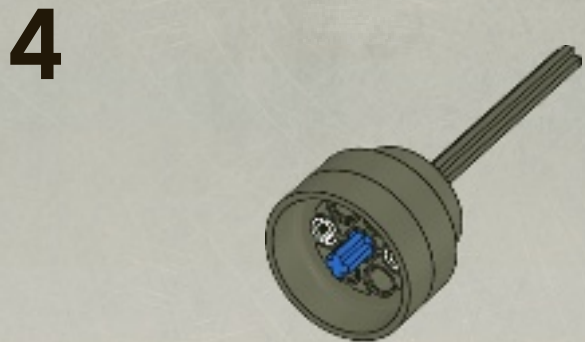
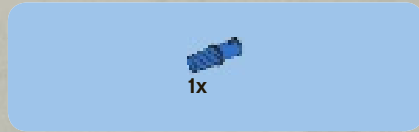
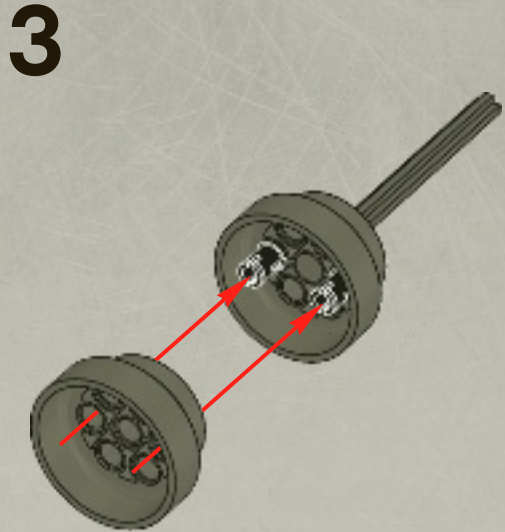
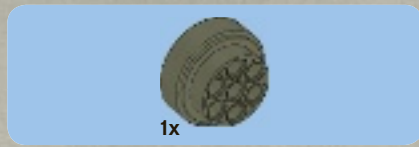
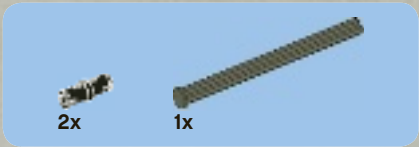
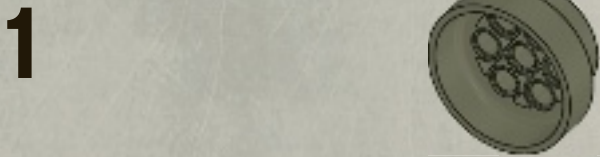
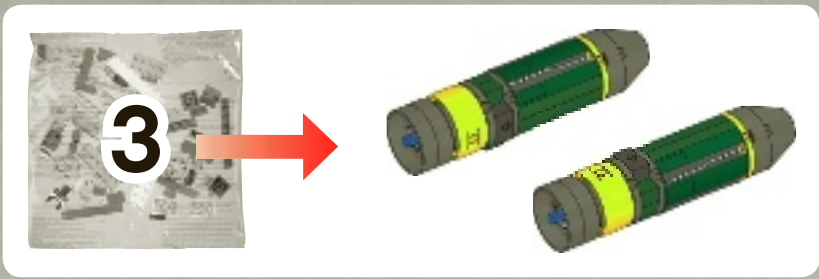





1x

5

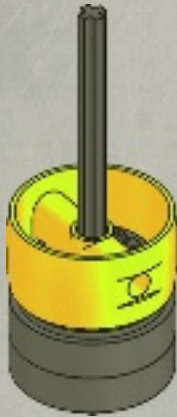

1x



2x



2x

6

1



2

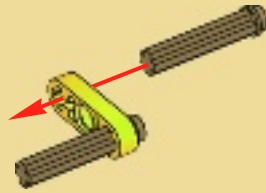

3

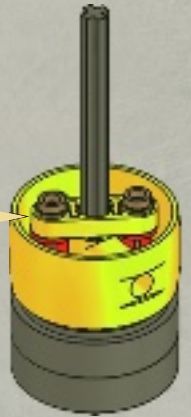
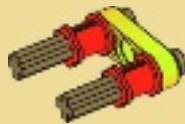

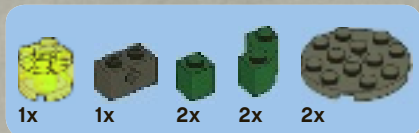

7

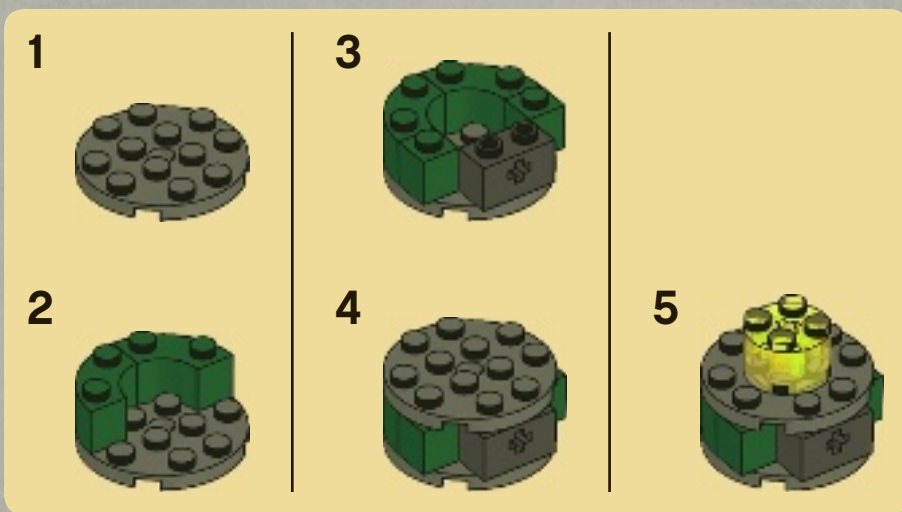

CLICK!





1x

8



1x

9



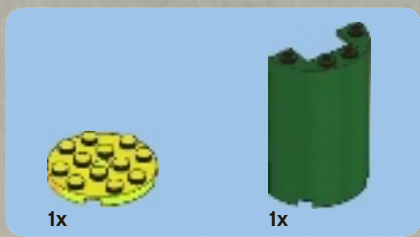

10



11





1x

# 12



1x



1x



1x

# 13

1



2



# 2x

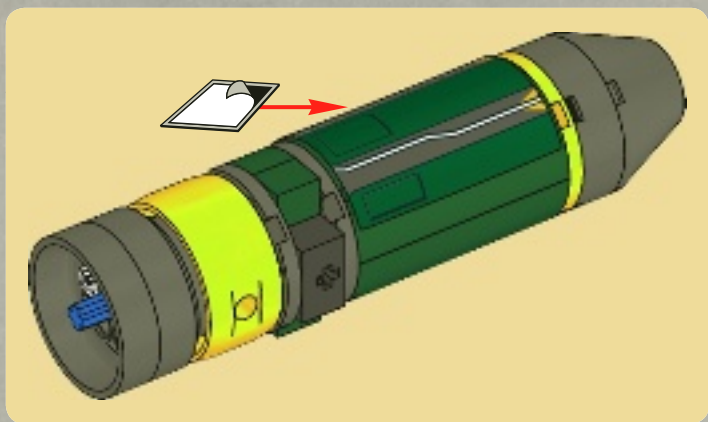

14

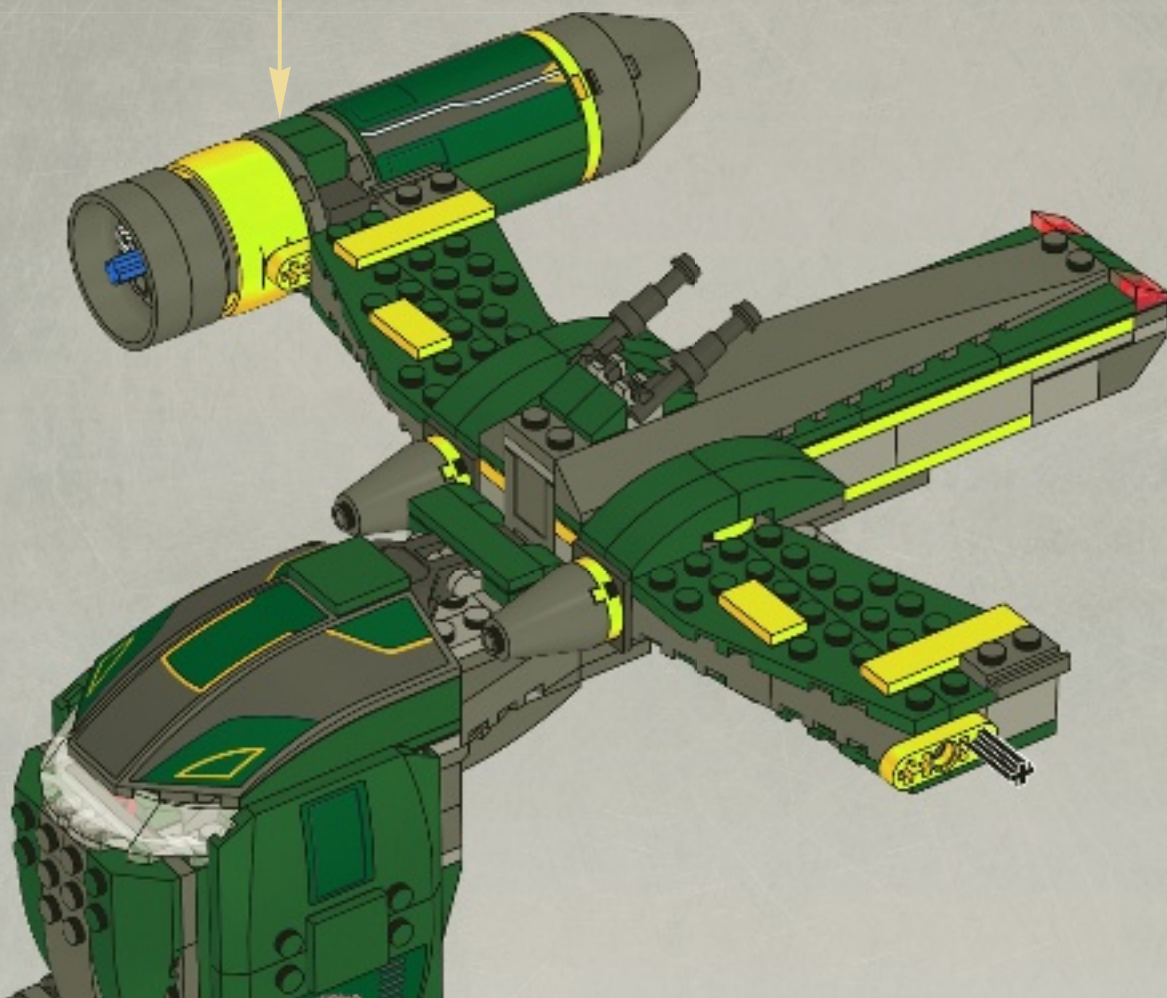

15

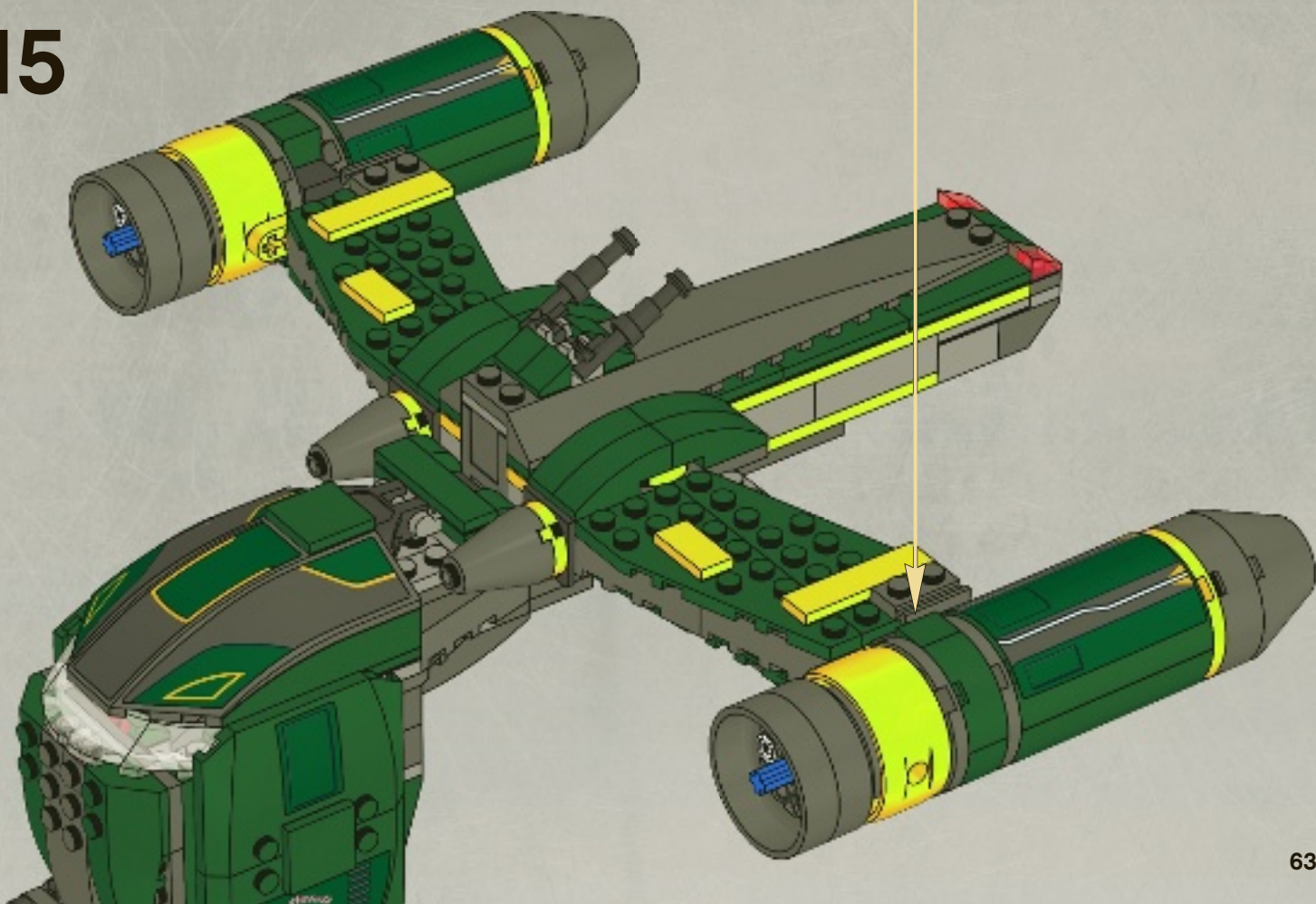
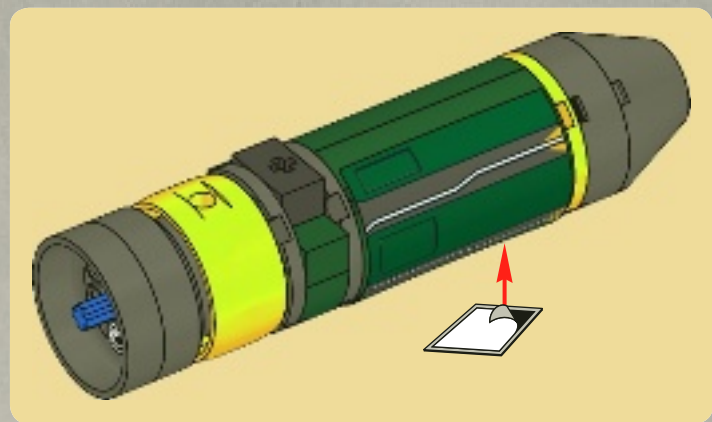

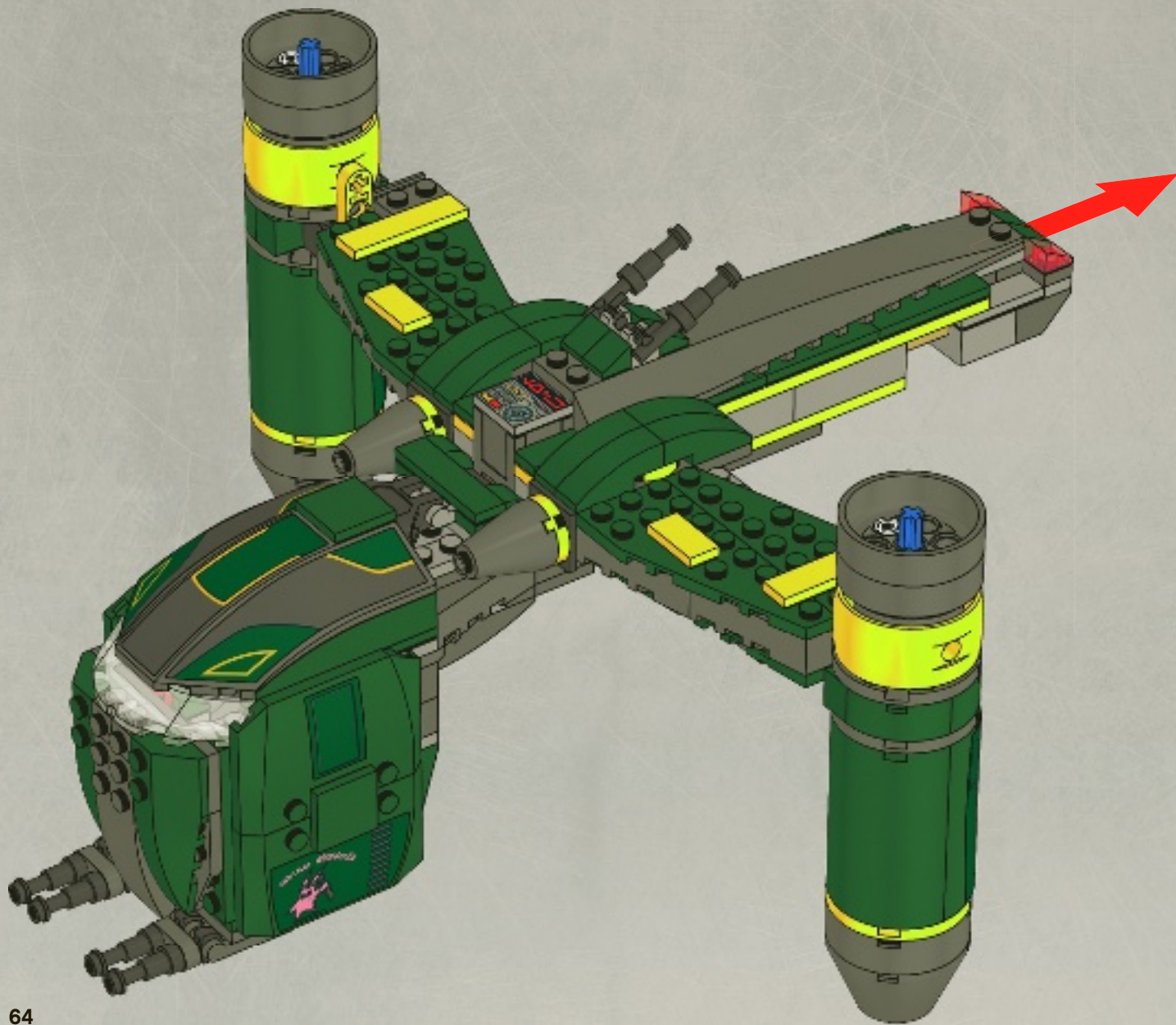





2x

17

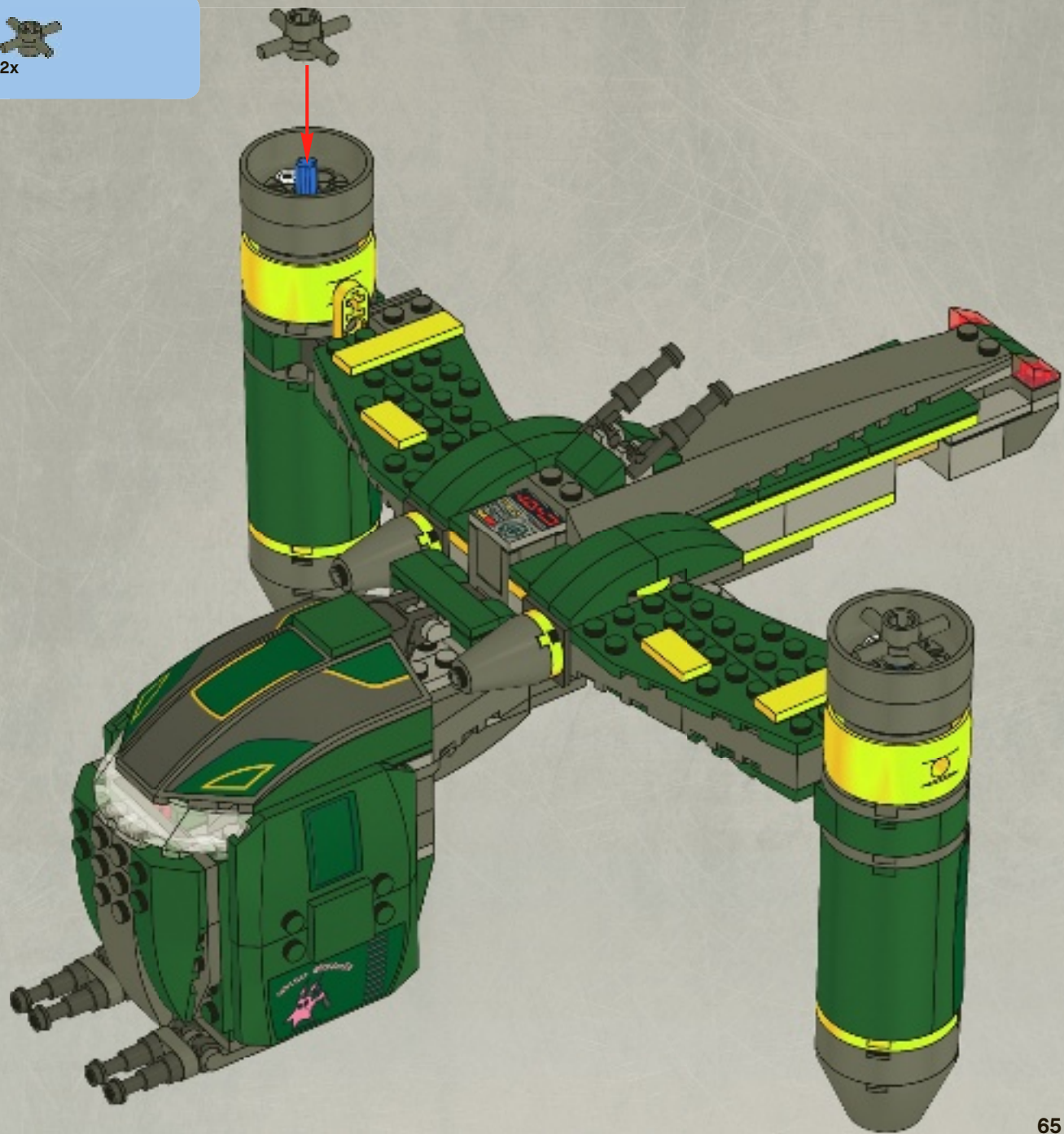



18

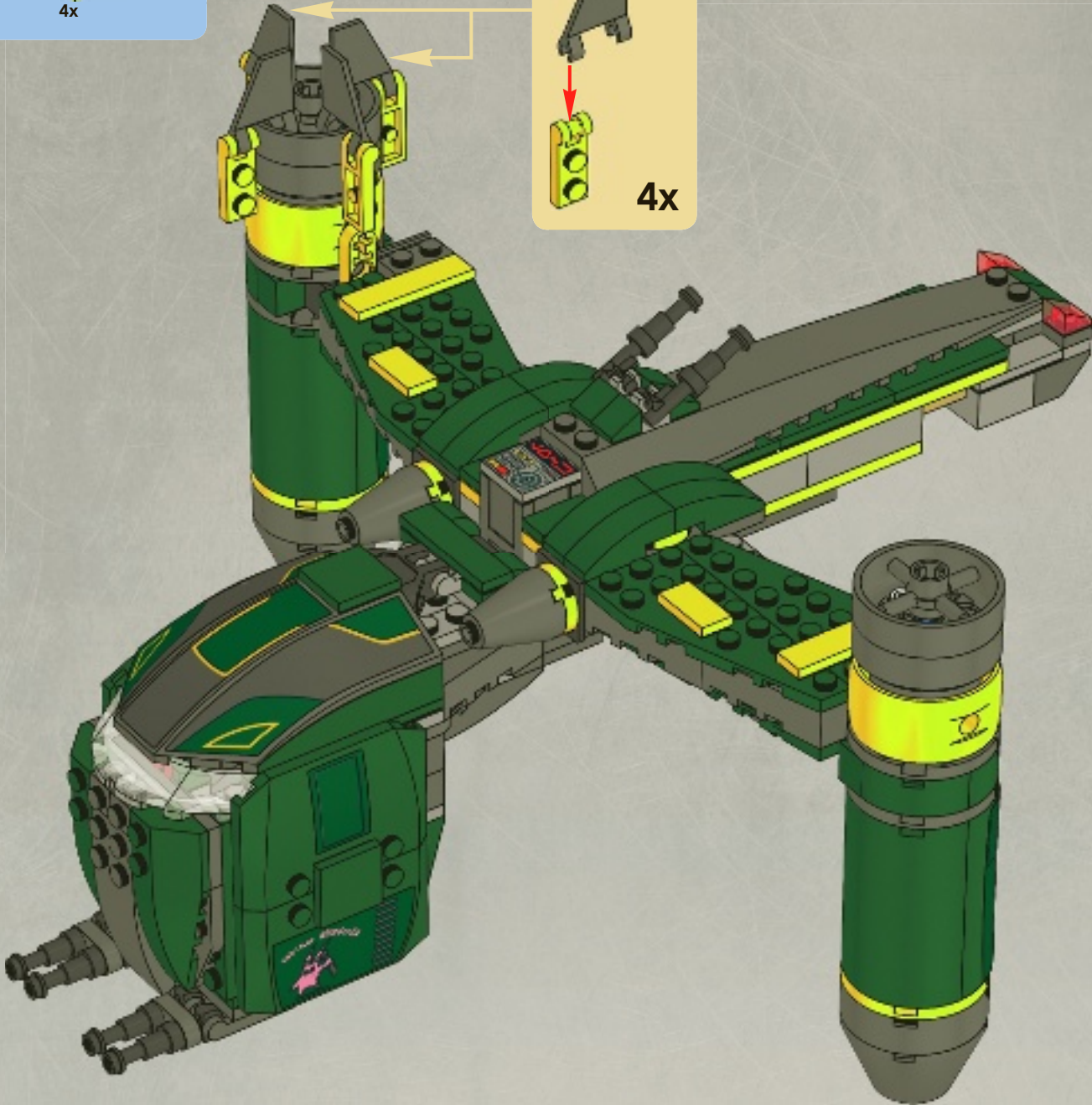



4x



4x

# 19

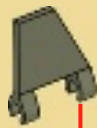

4x

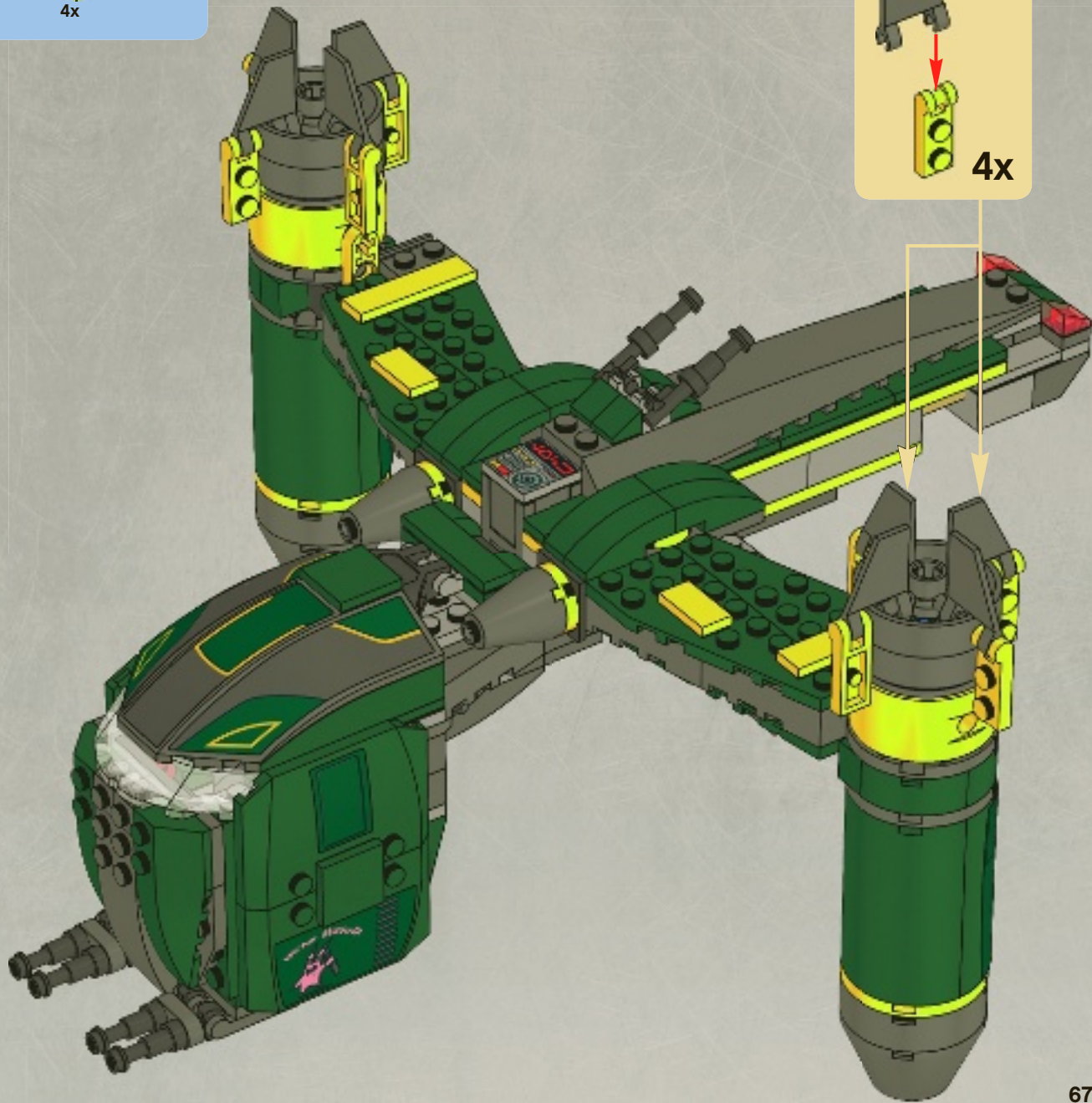

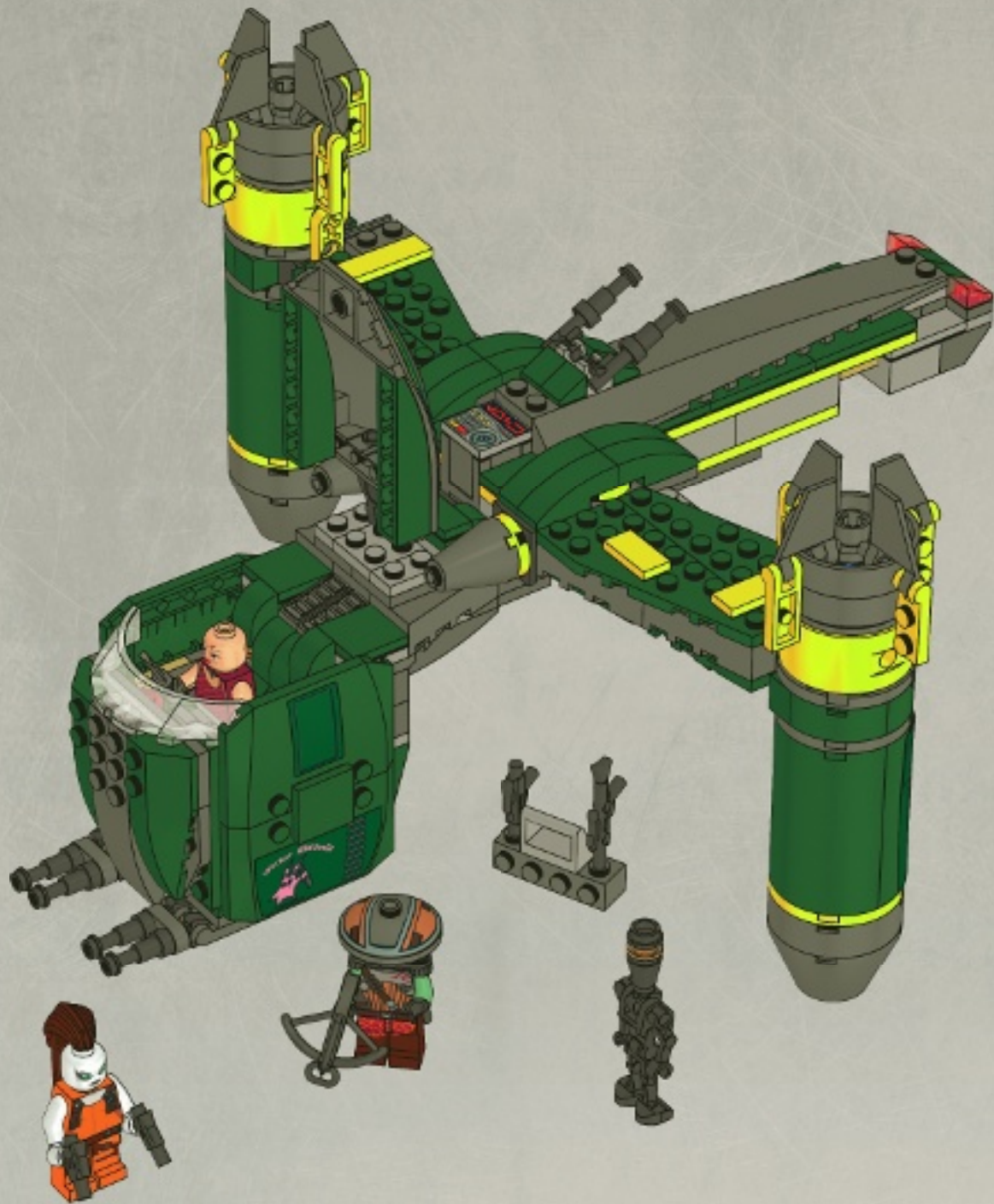

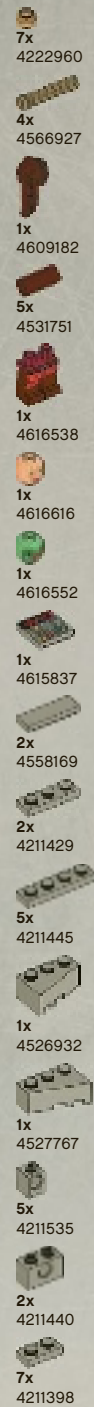
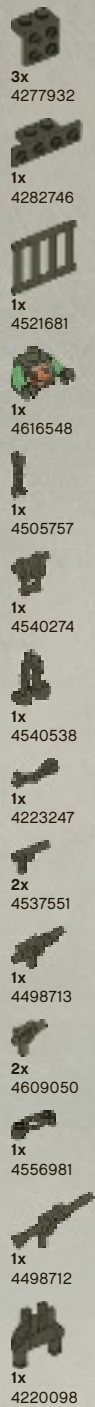



1x  
4617248



4x  
4613919



4x  
4245566



2x  
4255624



2x  
4583836



6x  
4588024



8x  
4267850

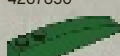

2x  
4612957



1x  
4276003

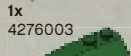

1x  
4276005



5x  
4528778



4x  
4521915



8x  
4504375



13x  
4543949



4x  
4583839



4x  
4615164



2x  
4250117



2x  
4616171



2x  
4293614



2x  
4293615



2x  
4211060



1x  
4210725



2x  
4211108



2x  
4222113



3x  
4211088



2x  
4543086



4x  
4196768



6x  
4521187



1x  
4227517



1x  
4616513



4x  
4528323



1x  
4520307



8x  
4215387



1x  
4235863



2x  
4542586



1x  
4551044



2x  
4558959



3x  
4287972



3x  
4287973



2x  
4540386



2x  
4211000



2x  
4211045



8x  
4210779



1x  
4210873

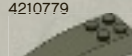

2x  
4521572

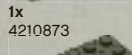

2x  
4222192



2x  
4210980



1x  
4211052



4x  
4549886



2x  
4558955



5x  
4210635



5x  
4211043



2x  
4598769



2x  
4499858



2x  
4211065

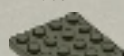

1x  
4243831

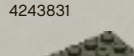

2x  
4211002



2x  
4210997

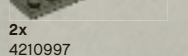

1x  
4161239



1x  
4211134



1x  
4211122



1x  
4260406



Customer Service

Kundenservice

Service Consommateurs

Servicio Al Consumidor

[www.lego.com/service](http://www.lego.com/service) or dial



00800 5346 5555 :



1-800-422-5346 :





Sugi™



Assassin Droid™



Embo™



Aurra Sing™

**LEGO**

**STAR  
WARS**™







7913



7914



7915



7968



7969



7929



7930



7931



# NINJAGO

Masters of Spinjitzu



NINJAGO.COM



[www.LEGOclub.com](http://www.LEGOclub.com)



LEGO® Club Email

**LEGO club**™

**FREE! GRATIS! GRATUIT!**



LEGO® Club Magazine

**SIGN UP ONLINE!**

**[www.LEGOclub.com](http://www.LEGOclub.com)**



**00800 5346 5555\***



**1-866-534-6258 • 1-877-518-5346**

US & Canada only

Canada seulement

\* Freephone. Mobile charges may apply.  
\* Numéro sans frais. Des frais peuvent s'appliquer avec les téléphones cellulaires.  
\* Gebührenfrei, Kosten für Anrufe aus Mobilfunknetzen können abweichen.  
\* Gratis telefonnummer vanaf vaste lijn.  
\* Det är et gratis nummer, når du ringer fra fasttelefon.  
\* Det är gratis, när du ringer från en fast telefon.  
\* Numéro sans frais. Des frais peuvent s'appliquer avec les téléphones portables.



# WIN!

Go to [www.LEGOsurvey.com/product](http://www.LEGOsurvey.com/product) to fill out a survey for a chance to win a cool LEGO® Product.

No purchase necessary.

Open to all residents where not prohibited.



[www.LEGO.com](http://www.LEGO.com)



## [www.LEGOsurvey.com/product](http://www.LEGOsurvey.com/product)

### GEWINNE! WIN!

Nimm an der Umfrage auf [www.LEGOsurvey.com/product](http://www.LEGOsurvey.com/product) teil und hab die Chance ein cooles LEGO® Produkt zu gewinnen!

Die Teilnahme am Gewinnspiel führt zu keinerlei Kaufverpflichtungen. Teilnahme in allen nicht ausgeschlossenen Ländern möglich.

Ga naar [www.LEGOsurvey.com/product](http://www.LEGOsurvey.com/product), vul een enquêteformulier in en maak kans op een cool LEGO® product.

Geen aankoopverplichting. Iedereen mag deelnemen, uitgezonderd ingezetenden van landen waar een enquêteverbod geldt.

### GAGNE! 当てよう!

Visite [www.LEGOsurvey.com/product](http://www.LEGOsurvey.com/product) pour répondre à un questionnaire et avoir une chance de gagner un produit LEGO® très cool!

Aucune obligation d'achat. Ouvert à tous les résidents des pays autorisés.

[www.LEGOsurvey.com/product](http://www.LEGOsurvey.com/product) にアクセスして、アンケートにご記入ください。当選者にはレゴ®製品を差し上げます。

お買い上げの必要はありません。

禁止されていない限り、すべての皆様にご利用いただけます。

LEGO and the LEGO logo are trademarks of the/son/ des marques de commerce de/son marcas registradas de LEGO Group. ©2011 The LEGO Group.

© 2011 LucasFilm Ltd. & TM. All rights reserved/Tous droits réservés./Todos los derechos reservados.